

31.018S *

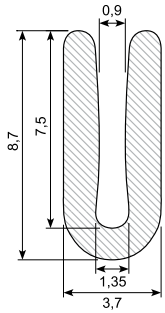

Material: Black EPDM
Hardness: SH 65
Min. order: 4.100 m

31.018X

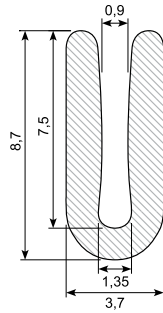

Material: PVC black
Hardness: SH 65

34.018 / 34.018X

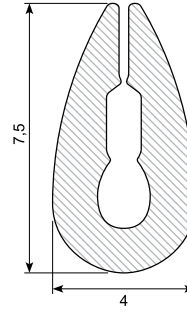

Material: Light grey PVC
Hardness: Soft

34.14334X

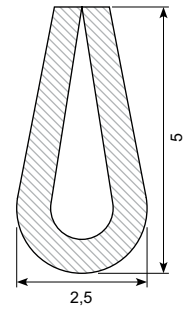

Material: Black PVC
Plade: 1,5 - 2 mm

31.060S

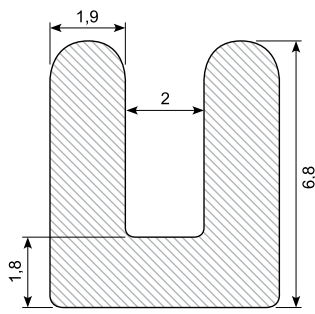

Material: EPDM black
Hardness: SH 65

31.041S

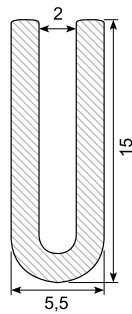

Material: EPDM black
Hardness: SH 65

31.042S

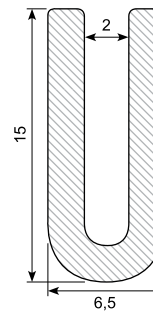

Material: EPDM black
Hardness: SH 65

30.OT3394 *

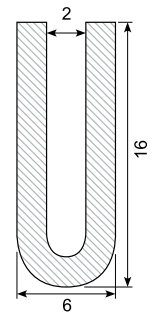

Material: Silicone black
Min. order: 100 m

31.047 *



Material: EPDM black
Hardness: SH 65
Min. order: 1.000 m

31.063

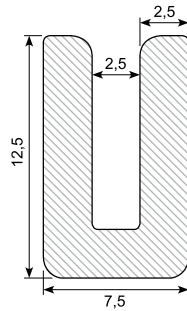

Material: EPDM black
Hardness: SH 65

30.9548

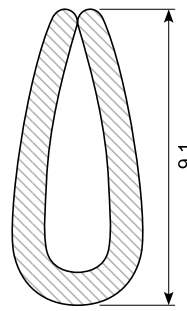

Material: Light grey hard PVC
Length: 3,9 m

31.025S

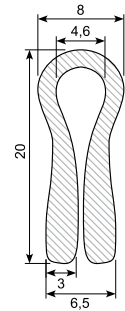

Material: EPDM black
Hardness: SH 65

31.021S

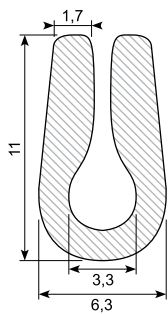

Material: EPDM black
Hardness: SH 65

31.022S

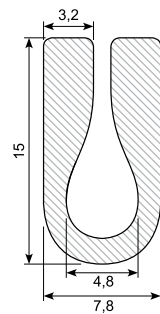

Material: EPDM black
Hardness: SH 65

34.031 / 34.031X

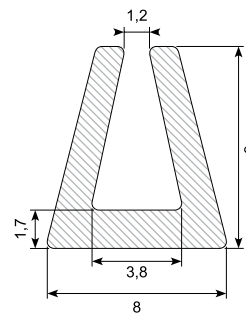

Material: PVC transparent
Hardness: Soft

30.13086

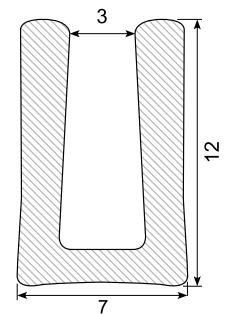

Material: EPDM black
Hardness: SH 80

U-profiler / U-profiles

31.043S

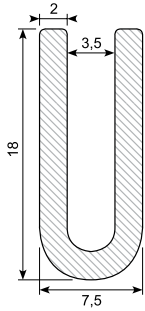

Material: EPDM black
Hardness: SH 65

31.064

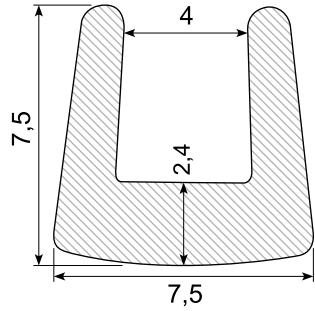

Material: EPDM black
Hardness: Hard

31.065S

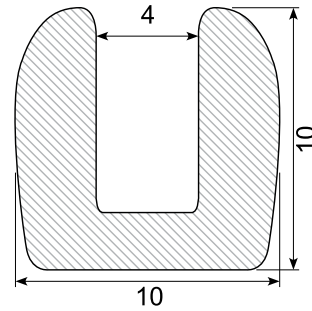

Material: EPDM black
Hardness: SH 65

31.061S

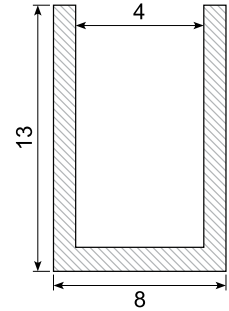

Material: EPDM black
Hardness: SH 65

30.6622N

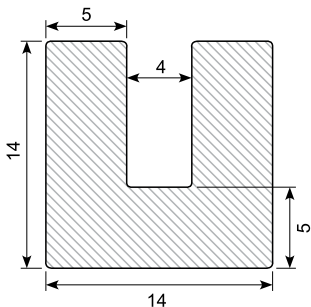

Material: NBR black
Hardness: SH 65
Oil resistant

30.6622 *

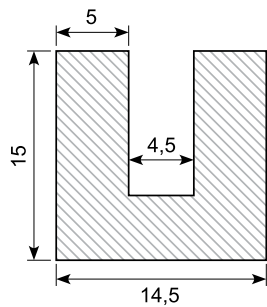

Material: EPDM black
Hardness: SH 65
Min. order: 500 m

31.216ST

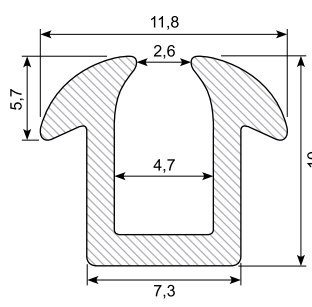

Material: EPDM black
Hardness: SH 65

31.216GS

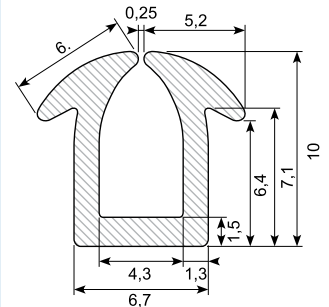

Material: Silicone light grey
Ral 7040
Hardness: SH 70

30.11459 *

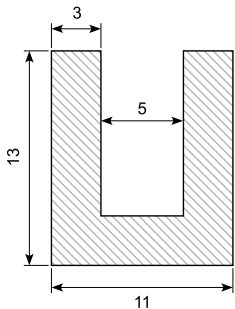

Material: Silicone transparent
Hardness: SH 45
Min. order: 250 m

34.035

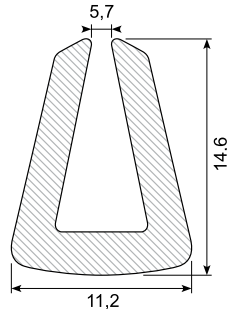

Material: PVC transparent
Hardness: Hard

31.066

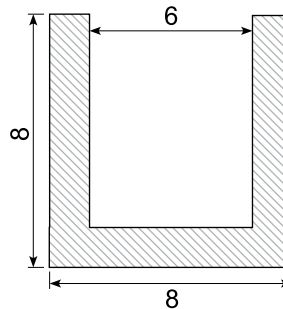

Material: Silicone black
Hardness: SH 70

30.6724

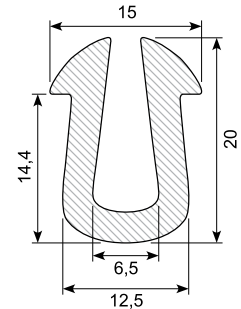

Material: EPDM black
Hardness: SH 65

30.14507-1 *

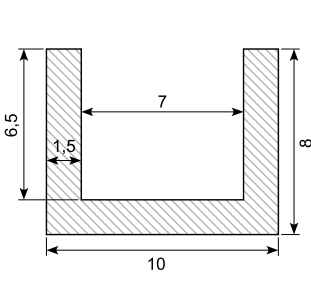

Material: EPDM black
Min. order: 3.000 m

30.14507-2 *

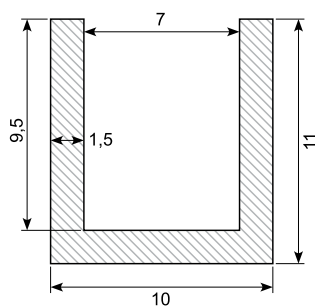

Material: EPDM black
Min. order: 3.000 m

31.068S

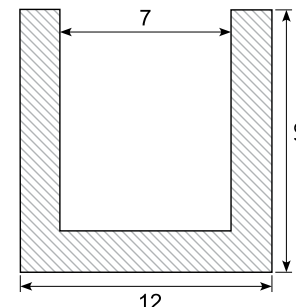

Material: EPDM black
Hardness: SH 65

30.1386

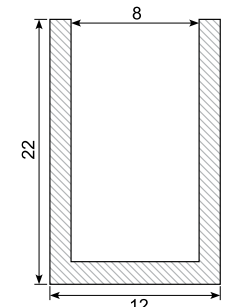

Material: EPDM black
Hardness: SH 65

30.OT3440 *

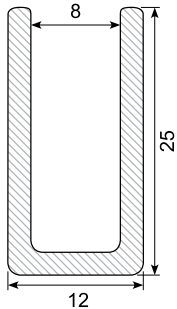

Material: Silicone black
 Hardness: SH 60
 Min. order: 100 m

30.12896

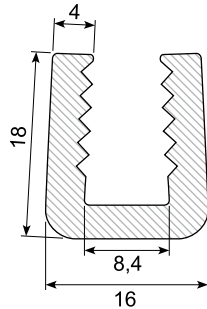

Material: EPDM black
 Hardness: SH 65

31.074S *

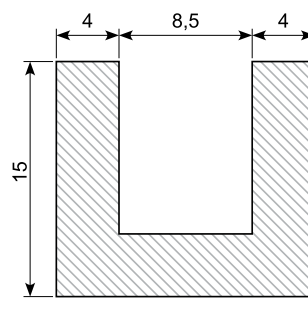

Material: EPDM black
 Min. order: 1.000 m

30.7987

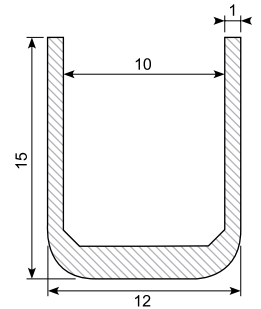

Material: EPDM black
 Hardness: SH 65

30.OT0136 *

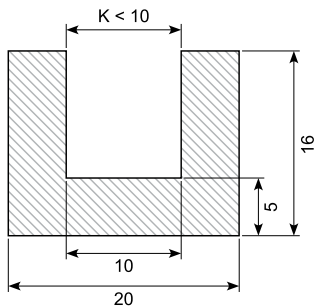

Material: White silicone
 Min. order: 100 m

31.070S

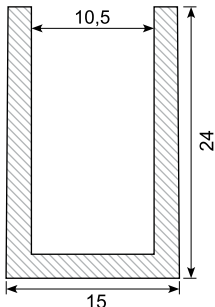

Material: EPDM black
 Hardness: SH 50

31.071S

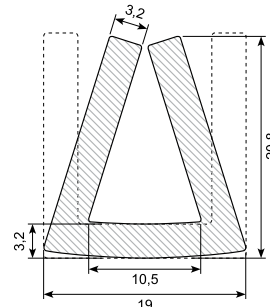

Material: EPDM black
 Hardness: SH 65

30.2449

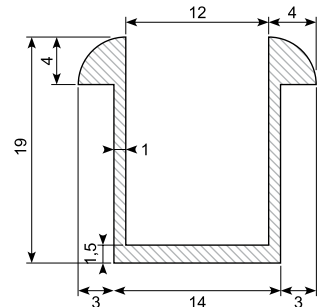

Material: Black PVC
 Length: 1.415 mm

30.2455

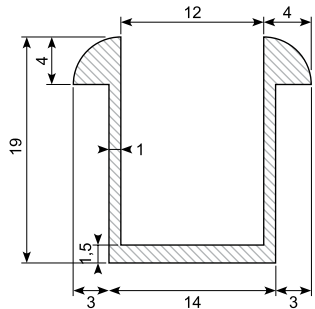

Material: Black PVC
 Length: 3.111 mm

30.11774

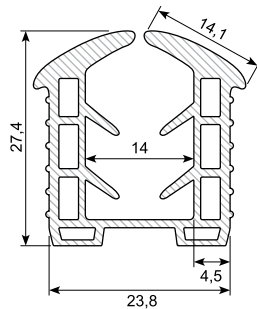

Material: EPDM
 Hardness: SH 65

30.7508 *

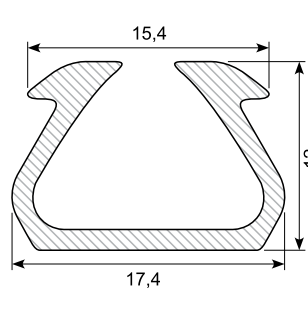

Material: EPDM black
 Hardness: SH 65
 Min. order: 400 m

30.9519

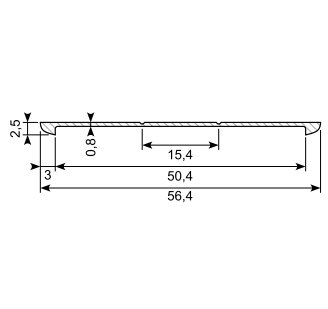

Material: Black soft PVC

30.12932-1 *

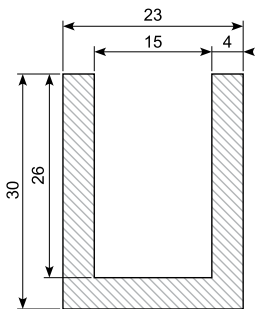

Material: Black EPDM
 Hardness: SH 60A
 Min. order: 500 m

30.13535 *

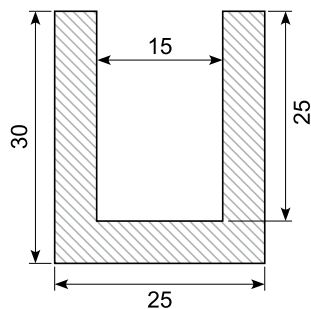

Material: EPDM black
 Hardness: SH 60
 Min. order: 420 m

30.7509

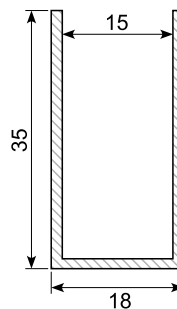

Material: EPDM black
 Hardness: SH 65

30.10777-1 *

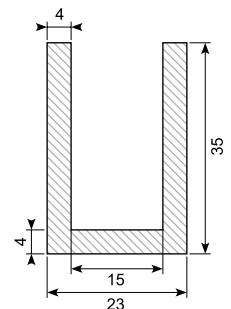

Material: TPE black
 Hardness: SH 60
 Min. order: 100 m

30.21101205

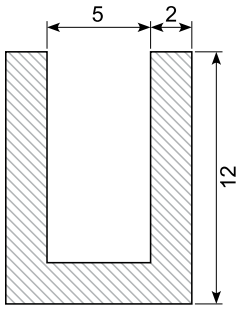

Material: EPDM
Hardness: SH 70

30.14507-3 *

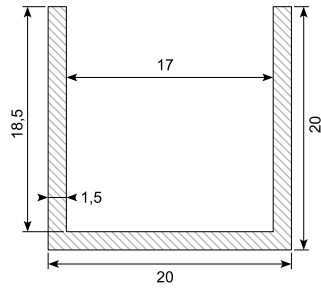

Material: EPDM
Min. order: 2.000 m

31.050

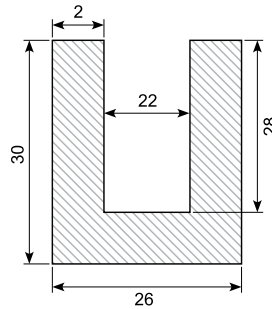

Material: EPDM black
Hardness: SH 65

30.14356

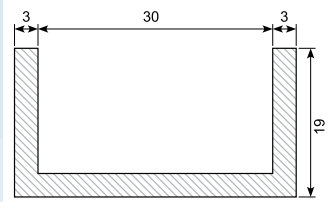

Material: Black TPE
Hardness: SH 60

31.048 *

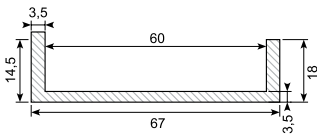

Material: EPDM black
Hardness: SH 65
Min. order: 250 m

30.11911 *

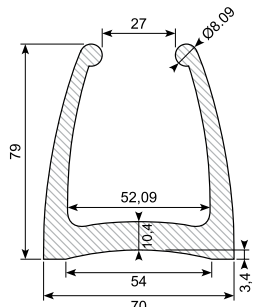

Material: EPDM
Hardness: SH 65
Min. order: 120 m

30.2984-5

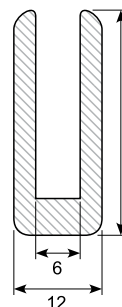

U-profile
Material: EPDM
Hardness: SH 70

34.117/6

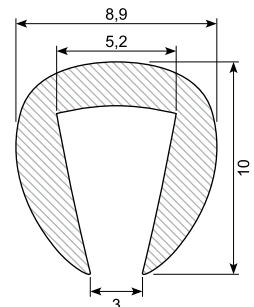

Material: Metal grey plastic

30.2984-6

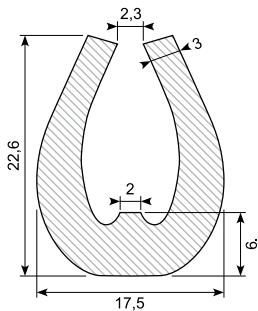

U-profile
Material: EPDM
Hardness: SH 80
Roll of 50 m

30.2984-1

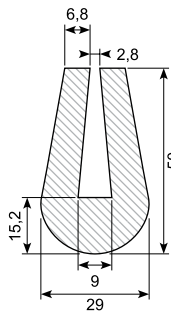

U-profile
Material: EPDM
Hardness: SH 70
Roll of 25 m

30.2984-2

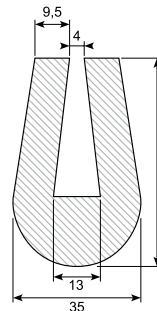

U-profile
Material: EPDM
Hardness: SH 65
Roll of 25 m

30.2984-3

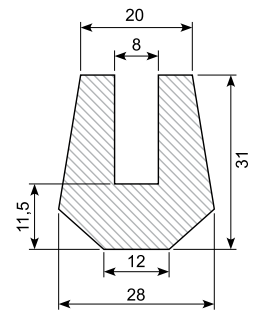

U-profile
Material: EPDM
Hardness: SH 70
Roll of 25 m

30.7519NBR *

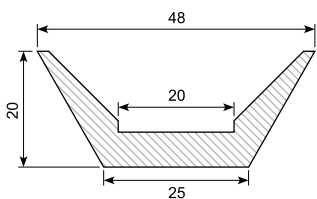

Material: NBR grey
Hardness: SH 65
Length: 3 m
Min. order: 500 m

Oil resistant
* Skaffevare / Special order item

30.7519 *

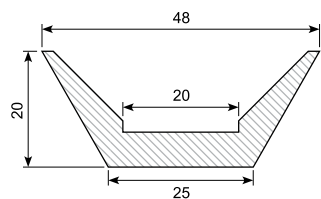

Material: EPDM black
Hardness: SH 65
Length: 50 m coils
Min. order: 50 m

30.14227 *

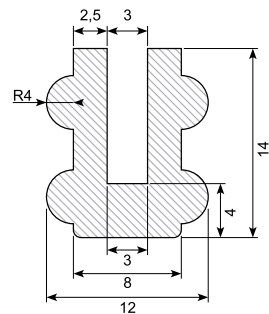

Material: Transperent silicone
Min. order: 100 m

31.037SI

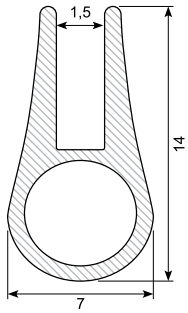

Material: Black silicone

31.035S

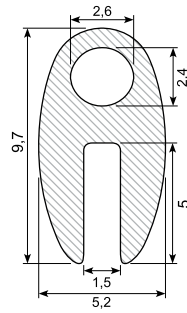

Material: EPDM black
Hardness: SH 65

31.036SI *

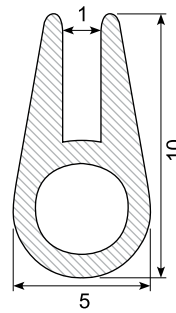

Material: Silicone black
Min. order: 200 m

31.036SI-LTC *

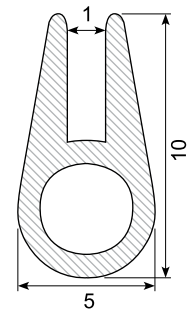

Material: Silicone black
UL94 approved
Min. order: 1.000 m

30.9884X *

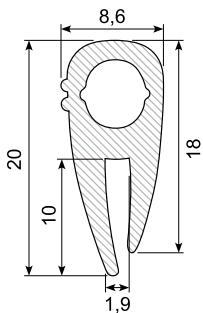

Material: EPDM
Min. order: 3.000 m

31.037 *

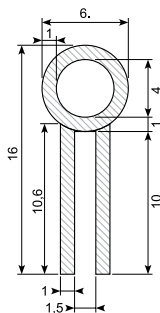

Material: EPDM
Hardness: SH 56 - 60A
Min. order: 2.000 m

30.9885

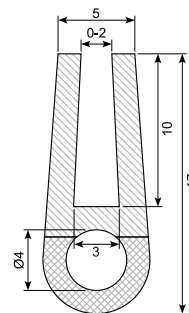

Material: EPDM
Hardness: SH 60

31.038SI

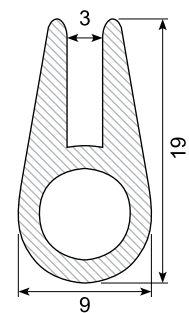

Material: Silicone black
Hardness: SH 60