

MURZAN

SANITARY PUMPS PI-50



INDUSTRIES
WE SERVE



Food



Beverages



Poultry, Meat
& Seafood



Pharmaceutical



Cosmetics

SANITARY PUMP PI 50

CONSTRUCTION

- 304 SS (PI 50 DL model) and 316L SS (PI 50 SL model) . Valve center block on all models is 316 SS.
- Diaphragms, gaskets and valve balls made of BUNA N, EPDM, VITON, and TEFLON.
- Pump certifications: USDA, FDA, EHEDG, 3-A.
- CIP Capable.

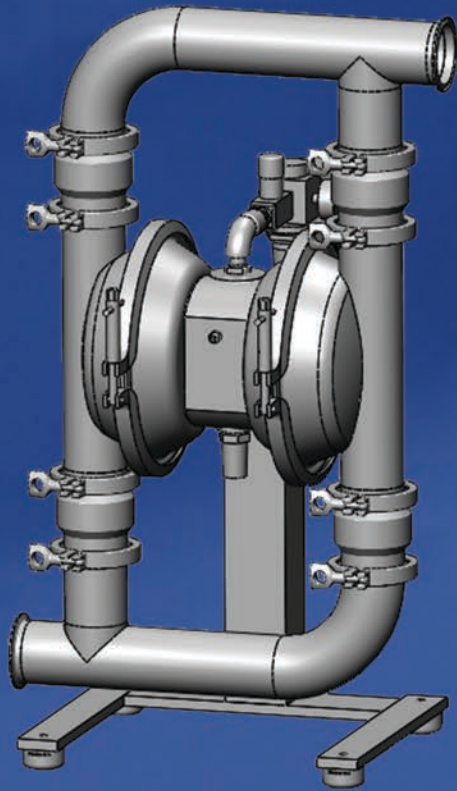

- Base constructed of polished 304 stainless steel and equipped with rubber feet (casters optional).
- Tri-clamp sanitary connection standard, optional sizes : 2"x2"; 3"x3"; 4"x4" and 6"x6".

OPERATION

- Oil Free air valve needs no lubrication and eliminates potential environmental contamination.
- Mechanically activated and adjustable anti-freezing feature.
- Unique design allows for total visual inspection of all wetted parts.
- Inter-changeable check valves, and universal parts.

CAPACITY

- Self priming up to 24 feet.
- Viscosities up to 150,000 CP.
- Solids up to 6" (15 cm).

ADVANTAGES

- Costly drives and special motors are not required.
- No mechanical seals to replace.
- Lightweight and mobile.
- Can run dry without damage.
- Easy to take apart and put together.
- Variable flow control.
- Delicate pumping for shear sensitive fluids.
- For portable and permanent installations.

APPLICATIONS



Food

Cottage Cheese
Yogurt
 Tomato paste
Vegetable Soups
Pie fillings



Beverages

Fruit Juice Concentrate
 Frozen Concentrate
Orange Juice



Poultry, Meat
& Seafood

Ground beef
Chicken Livers
 Chicken Gizzards
Eggs