

Standard executions		
Version	Code	Item
Bore 10 mm	075023	10PAB
Bore 16 mm	075004	16PAB
Bore 20 mm	075006	20PAB
Bore 25 mm	075008	25PAB
Bore 32 mm	075010	32PAB



Series of pneumatic angular hand grips available in 5 different sizes.

They are standard magnetic with groves on the body allowing the direct mounting of magnetic reed switches.

For magnetic reed switch type ASC see from page 1.110.1.  
For mounting accessories see from page 1.80.60.

How to order : 20PAB/SE

Option	Suffix
Single acting	(to Ø 25) / SE

20	PAB	/SE
Bore	Type	Option

Technical data						
Type	10PAB	16PAB	20PAB	25PAB	32 PAB	
Fluid	Compressed filtered air with or without lubrication. Lubrication, if started, must be continued.					
Pressure	1,5 ÷ 7 bar					
Temperature range	0 °C ÷ +80° C					
Max. operation frequency	180 cycle / min.					
Lubrication	Piston: with or without lubrication Levers: lubrication is required on moving parts					
Holding moments M* (Ncm)	Closing*	1,6 x P	8 x P	17 x P	34 x P	61 x P
	Opening*	2,6 x P	11 x P	23 x P	43 x P	81 x P
Effective gripping force F (N)	F = M / L** x 0,85					
Maximum length of gripping point L (mm)	30	40	60	70	85	
Weight (g)	40	100	200	330	540	
Lever open/close angle	- 10° ÷ + 30°					
Ports	M3					M5

\* P = operating pressure (bar)

\*\* L = distance of the gripping point (mm)

## Materials

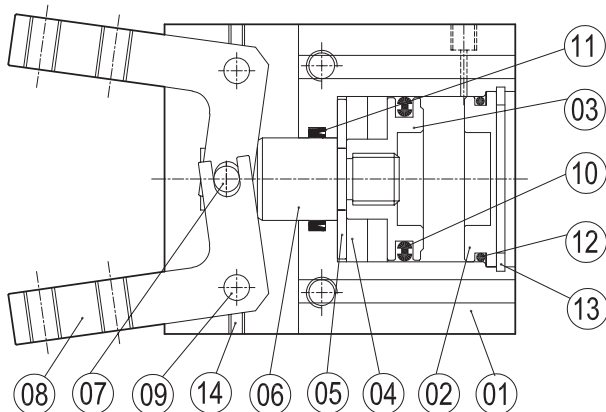

N.	Component	Material
1	Body	Aluminium
2	End cover	Brass
3	Piston	Brass
4	Magnet	Plastic magnet
5	Magnet holder	Brass
6	Piston rod	Stainless steel
7	Piston rod pin	Steel
8	Fingers	Steel alloy
9	Slide pin	Steel
10	Piston seal	NBR
11	Piston rod seal	NBR
12	End cover O-ring	NBR
13	Seeger	Steel
14	Hexagonal screw	Steel alloy

## Gripping forces

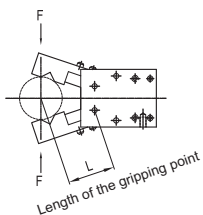
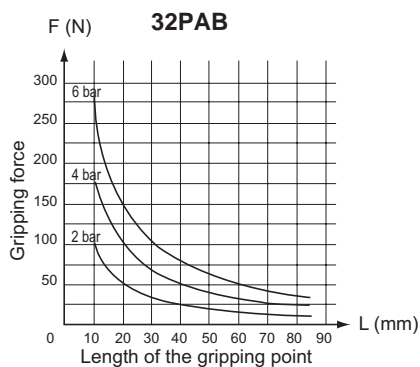
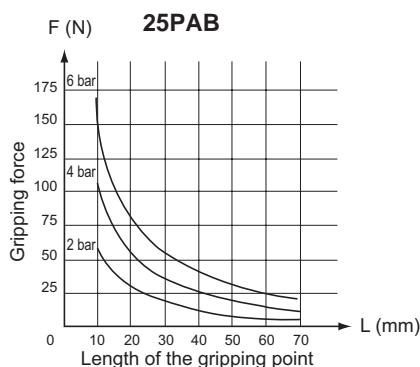
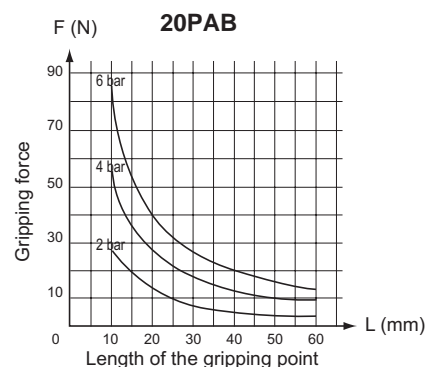
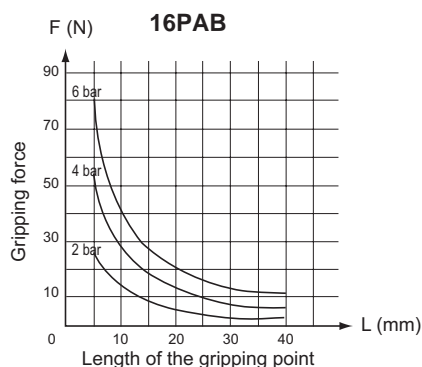
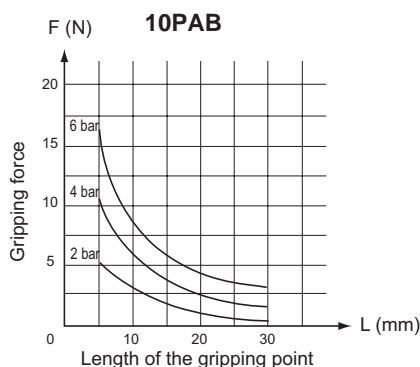

### Type: 10PAB

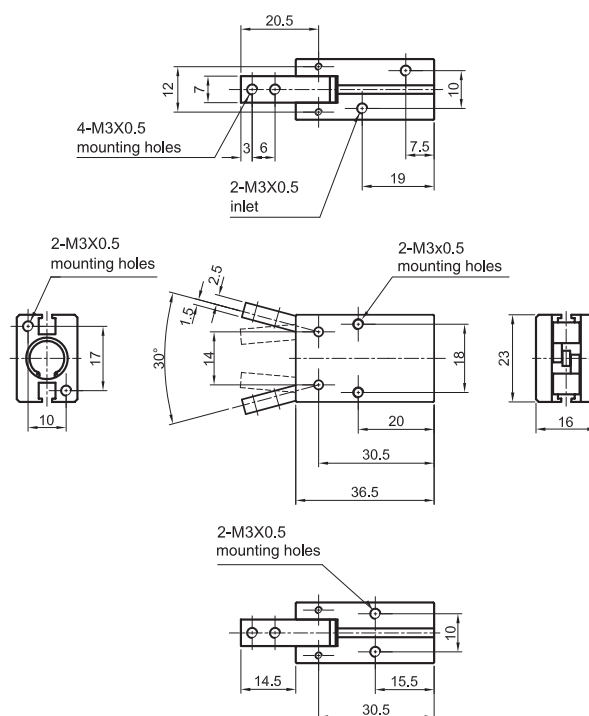

Type: 16PAB

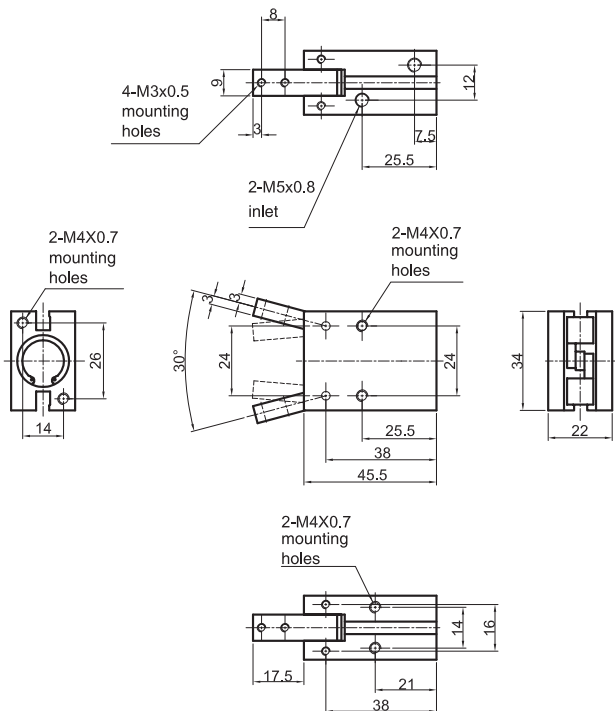

Type: 20PAB

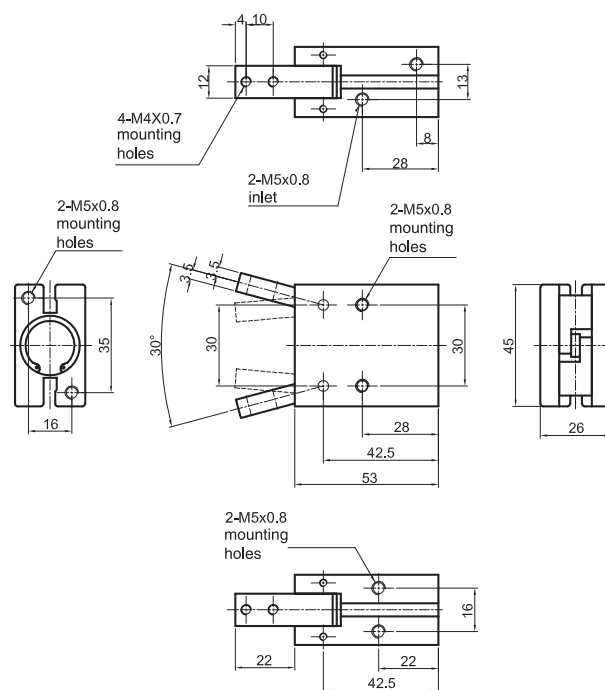

Type: 25PAB

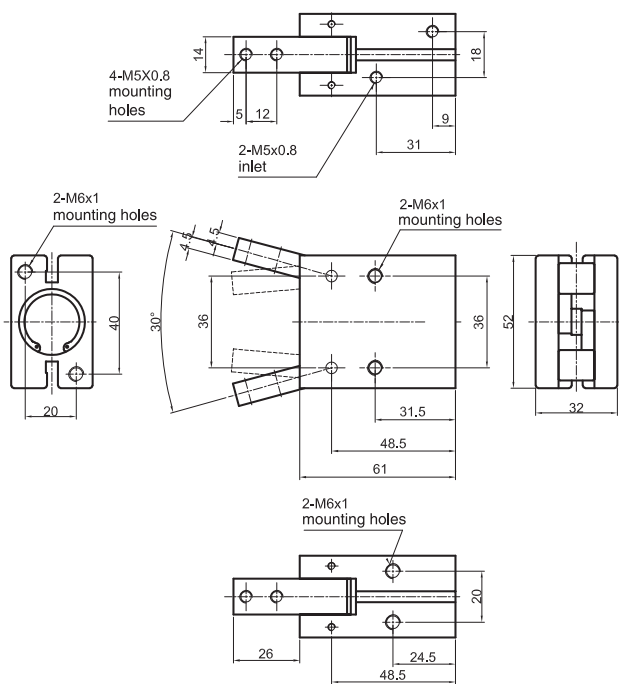

Type: 32PAB

