

DAIKIN

Hybrid System

Inverter-controlled
energy-saving systems

DAIKIN thinking about a better world.



DAIKIN INDUSTRIES, LTD.

Oil Hydraulic Division

Oil Hydraulic Equipment

DAIKIN contributes with fusion technology of oil hydraulics and inverter system for extreme environment and highly economical improvement.

DAIKIN introduced built-in magnet-type synchronous motors (IPM motor) into residential air conditioners first in the industry, and also into air conditioners for business use. We have been leading the industry as a top runner in energy-saving air conditioners. New hybrid systems equipped with variable speed motors based on this energy-saving motor technology and production capability can attain higher efficient factory

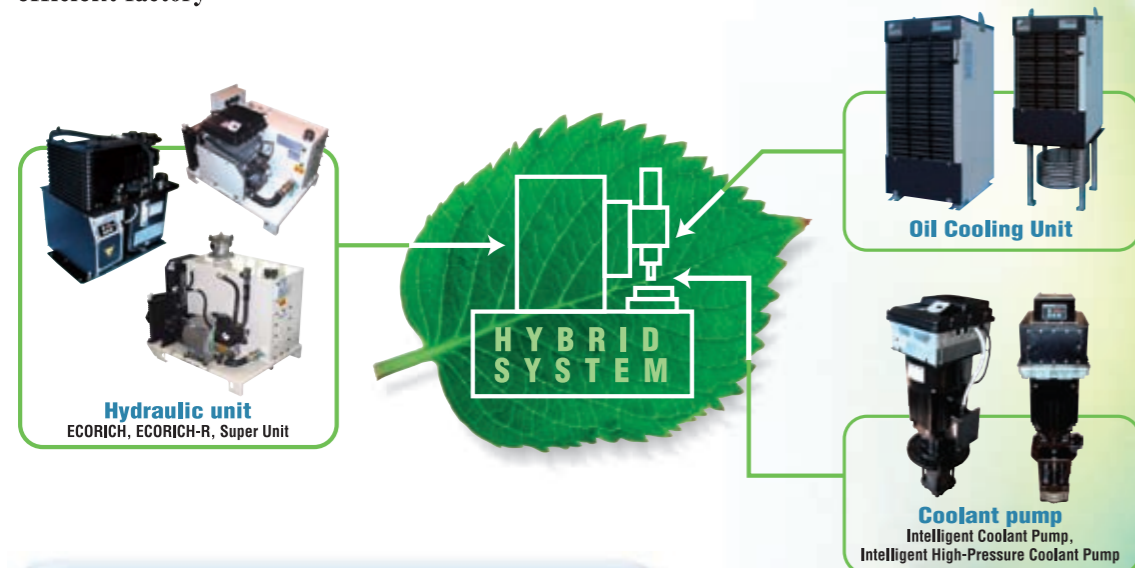

Features of HYBRID SYSTEM

"Hybrid System", equipped with multi-functional software, is a fusion of the conventional hydraulic technology and the electrical technology (inverter control) for higher energy-saving efficiency.

- 1** Fusion of DAIKIN original high-efficiency IPM motor drive system and the hydraulic technology attains higher energy-saving effect and higher response than the conventional hydraulic system.
- 2** Advanced functions of the hybrid system as a fusion of hydraulic technology and electrical technology.
- 3** Compact design equipped with high-efficiency IPM motor drive system.
- 4** Low noise attained by motor torque control under pressure-retained condition.

Social responsibility for the industry.

Various activities are being proceeded all over the world for preservation of global environment. The industry has been sharply requested to reduce the environmental influence. It is an important theme for each enterprise to solve such a problem. In fact, some support systems were established to promote these activities. Actions to meet the requirement also include very beneficial things improvement in cost reduction, high productivity and to strengthen the radical reform of each enterprise.

Global trend
Global warming control
Saving of energy resources
Ozone layer protection
Reduction of natural environmental load



Social requirement
(Symbiosis with environment)
Energy saving
Total abolition of fluorocarbon (HCFC)
Waste reduction and recycle
Air pollution control
CO₂ gas emission control

Major laws and regulations
Montreal Protocol (Revised in 1995)
Air Pollution Control Act CO₂ emission control
Fluorocarbon Recovery and Destruction Act (Enforced in 4/2002) *In Japan
Package and Container Recycle Act (Enforced in 4/2002) *In Japan
Recycle-related Act*In Japan

Do you know?

Actual conditions of energy consumption in factory process lines.

Power consumption of line in factory

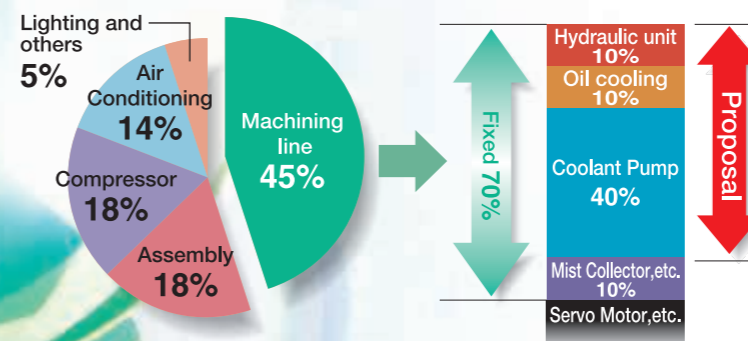

45% of total power consumption in factory is consumed in machining line. 70% of machining line is the fixed consumption regardless of production volume.

Most of the fixed consumption consists of hydraulic unit, oil cooling, and coolant pump. Though it is important to reduce these three parts, nobody touched these area because of direct influence on production.

Energy-Saving activity by reviewing machining facilities is indispensable to protect environment and improve productivity.

Contents

Concept	1
Energy-saving technology to support hybrid systems	3
ECORICH	5
ECORICH-R	7
SUPER UNIT	9
Intelligent Coolant Pump	13
Intelligent High-pressure Coolant Pump	15
Oil Cooling Unit	17
Capacity Chart	21
Specifications List	23
Optional Parts	31
Characteristics	34

Energy-saving technology for hybrid systems

Advanced technology greatly improves energy efficiency.

Energy saving

The combination of DAIKIN original inverter system and hydraulic technology greatly improves the energy saving effect. The high-speed response provides performance equivalent to or higher than the conventional variable displacement.

Example of actual application of hybrid system (Our machining line)

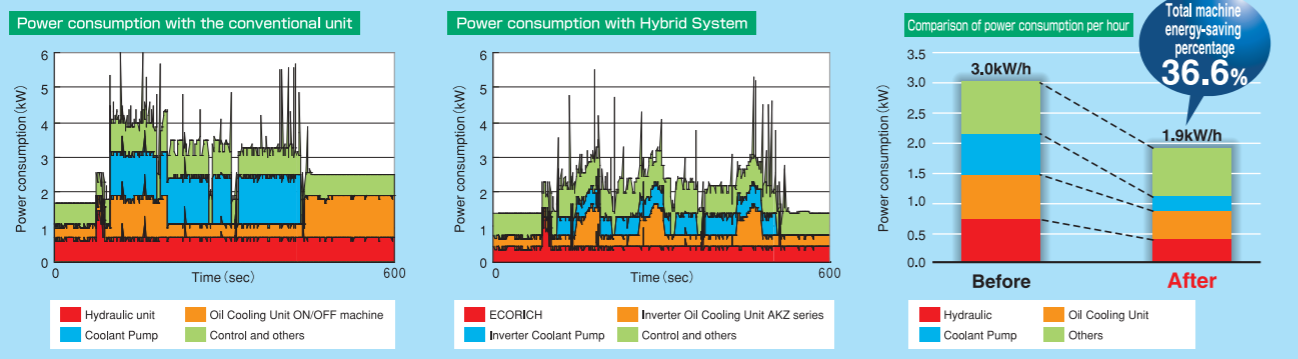

Sophisticated control (Super Unit)

- ◆ Pressure and flow rate (PQ) characteristics of 4 and 16 patterns are preset to the control unit. Select and input them on the main machine side, and multi-stage pressure and flow rate control can be easily attained.
- ◆ Adjust select rise/fall time in changing PQ characteristics, and shock-less control can be attained.
- ◆ The conventional valve control is replaced by pump control; and simple and low - cost systems can be produced for high/low press speed select and multi-stage pressure control.

Compact design

- ◆ High-efficiency IPM motor and inverter control reduce the pump discharge at standby. As the result, heat generation is suppressed and the tank capacity is reduced to be compact. (ECORICH, Super Unit)
- ◆ Smaller than 7 series, top-class in the industry. (Oil Cooling Unit)

New refrigerant (Oil Cooling Unit)

New refrigerant (R410A) does not destroy the ozone layer.

- ◆ Production of old refrigerant greatly decreases in 2004. New substitute HFC (R410A) which does not destroy the ozone layer was adopted to new models.

Low noise

60 dB (A) (20.6 MPa at pressure retained)

- ◆ The inverter-controlled motor can be rotated at the lowest speed required. The noise at pressure retained is greatly reduced. (Super Unit)

AKZ1.2HP class:

68dB (A) → 62dB (A) Corresponding value in anechoic chamber (Oil Cooling Unit)

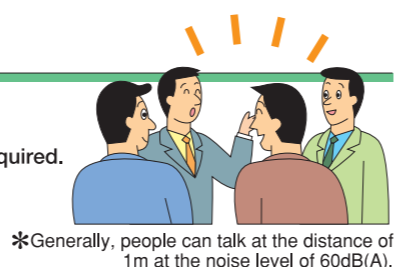

Energy saving technology to supporting hybrid systems

- ◆ DAIKIN introduced built-in magnet-type synchronous motors (IPM motor) into residential air conditioners first in the industry, and also into air conditioners for business use. We have been leading the industry as a top runner in energy-saving air conditioners.
- ◆ New hybrid systems equipped with variable speed motors based on this energy-saving motor technology and production capability can attain higher efficient factory.

"Double Torque, power of rotations" improves the energy saving effect.

In combination of two rotating forces of powerful neodymium*1 "magnet torque" and DAIKIN original "Reluctance torque*2", higher power can be generated at lower electricity.

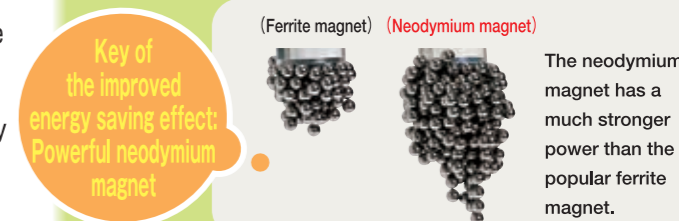

Principle of IPM motor

A rare-earth permanent magnet deeply positioned in the rotor can generate magnet torque (attraction/repulsion between coil and permanent magnet) and reluctance torque (coil attracts iron) greatly. This electromagnetic structure attains high torque and the highest efficiency/low heat generation.

Structure of IPM

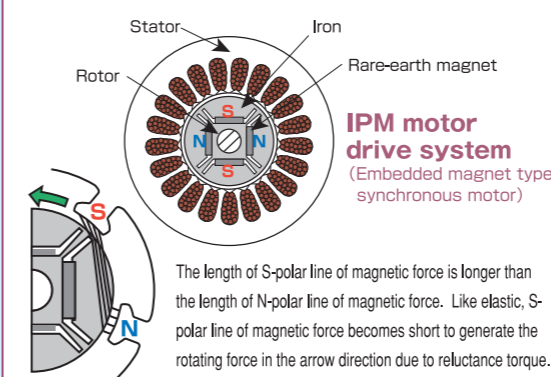

Structure of conventional motor (AC servo)

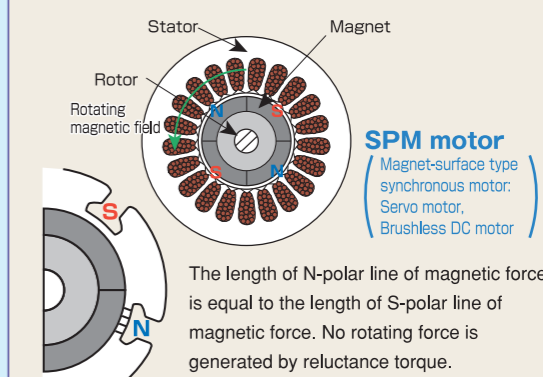

[1] Comparison of motor efficiency

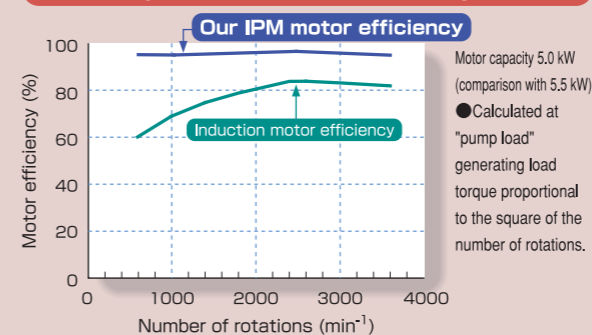

[2] Comparison of torque characteristic

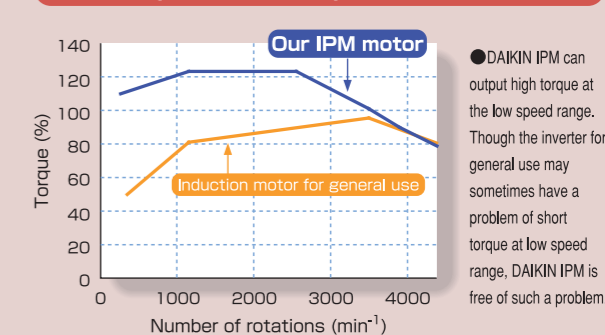

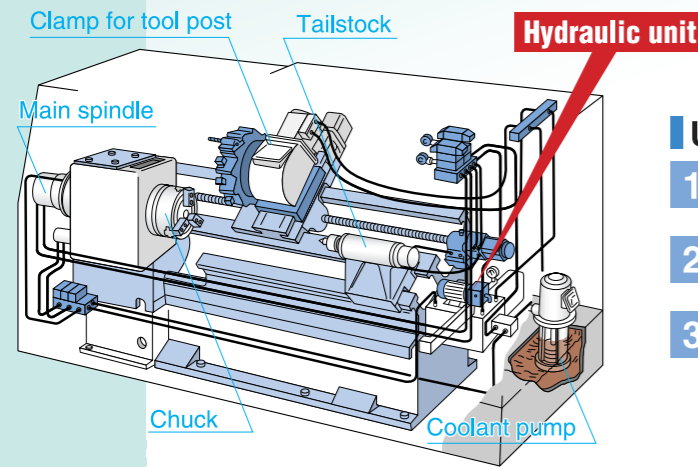

Used to supply control power

- 1 Chuck (chucking a work-piece)
- 2 Tail-stock (holding a work-piece)
- 3 Tool rest clamp (fastening a tool rest)

Principle of energy saving

Hydraulic operating pattern and energy-saving

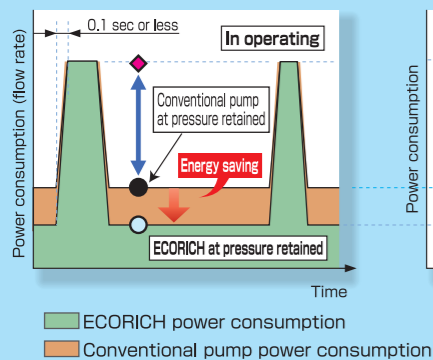

Principle of operation

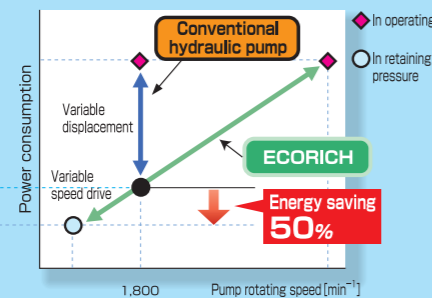

Autonomous energy-saving pressure-flow rate control

- ◆ Supplies required flow according to load condition by monitoring the pressure.
- ◆ Holds necessary pressure and operates at the minimum rotating speed required to compensate for leakage from circuit in retaining pressure. Rotates at high speed and supplies required flow when hydraulic actuator operates.

System configuration

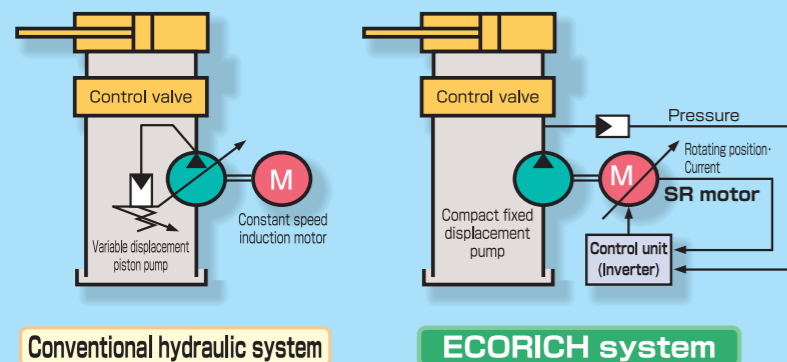

Easy installation and easy operation

- ◆ Only connect to 200V commercial power source to operate.
- ◆ Pressure and flow rate can be set on the touch panel.
- ◆ Pressure and flow rate are legibly displayed in digital.

Energy saving

Energy saving 50%

(Compared to our product, when pressure is retained)

- ◆ Drastic energy saving by reducing the motor rotating speed under pressure-retained condition.
- ◆ Our original SR motor control unit of high efficiency and compact fixed-displacement pump are applied.

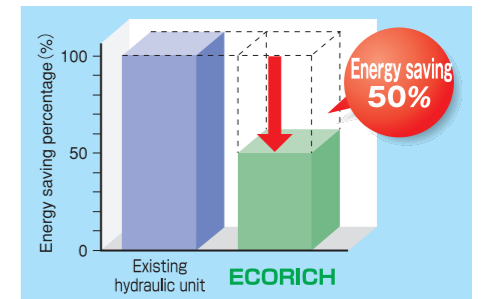

High-speed response

- ◆ Special SR motor, which has low inertia and generates high torque at low speed, and high-speed response inverter.
- ◆ Response equivalent to or higher than conventional variable displacement pump. (Pressure retained ↔ Operation at maximum flow rate: 0.1 sec or less)

Compact design and resources saving

- ◆ Resources-saving design with compact, lightweight and simple structure with no permanent magnet.
- ◆ Minimized fluid is supplied at low-speed rotation to improve the hydraulic oil in deterioration.

● Example of comparison with our rotor pack (Type NDR151, NDR231) equivalent to motor

EHU25-M07

Capacity comparison of installation area

NDR151-103L : **82%** (79kg)

NDR231-305 : **54%** (105kg)

Weight 48kg
336×464×509

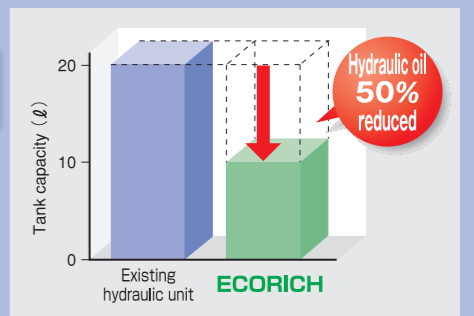

Specifications

Tank capacity	10 ℓ			
Motor capacity	equivalent to 0.75 kW	equivalent to 1.5 kW	equivalent to 2.2 kW	equivalent to 2.8 kW
Max. working pressure	4.0 MPa		7.0 MPa	6.0 MPa
Discharge adjusting range	4~14 ℓ/min	5~25 ℓ/min	5~25 ℓ/min	5~28.5 ℓ/min
Model	EHU14-L04	EHU25-L04	EHU25-L07	EHU25-M07
				EHU30-M07

ECORICH-R

Hydraulic unit

Daikin's EcoRich R is seeking energy saving and user-friendliness to the last extremity.

Developed energy saving with high-efficiency IPM motor drive system installed.

The system uses ultra energy-saving IPM motor*1, featuring combination of magnet torque (pull-in and repulsion force between coil and permanent magnet) and reluctance torque (pull-in force between coil and iron).

*1 IPM motor: Interior Permanent Magnet Synchronous Motor



High torque and high efficiency thanks to unique structure with rare-earth magnet embedded in depth of rotor.

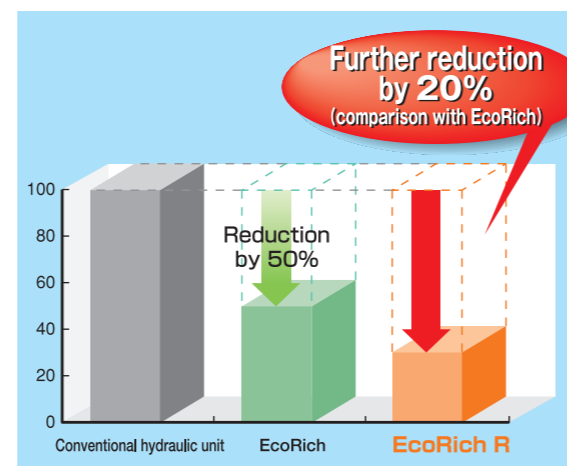

Monitoring proper amount of tank oil level.

Equipped with dry-run prevention function. This function stops operation automatically if an oil level in the tank drops below a certain gauge, preventing idle run of a pump. This contributes to prolonging a product life.

Extended hydraulic output area.

In comparison with conventional EcoRich, horsepower output has been extended by approximately 30%. Pressure setting is allowed starting from 0.5MPa.

Comparison of PQ characteristic between EcoRich and EcoRich R

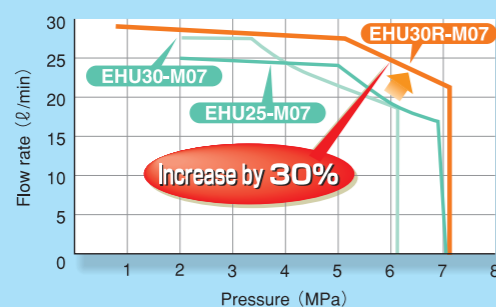

The technology of Eco-Rich has been evolved further. New IPM motor system achieved dramatic improvement of energy saving.

First in the world



Description of function

Operation of actuator (cylinder) with 4 patterns of pressures (P) and flow rate (Q) by multi-step pressure (force) and flow rate (speed) control.

No need for proportional valves and formal pressure valves required in conventional actuator circuits. Required operation is only entering P and Q settings on controller parameters and selecting a parameter of 4-pattern contact signals on a machine (main unit). Switching between flow rate control and pressure control is performed autonomously in EcoRich R. (For example, switching between flow rate and pressure controls at cylinder ends.) Operation of turning on/off solenoid valves for cylinder is required on the machine.

Shock-less switching of flow rate (speed) and pressure (force).

Force or speed of the machine can be changed in a shock-less manner when switching pressure or flow rate setting by setting optimal acceleration/deceleration times for the machine is set to the parameter in advance.

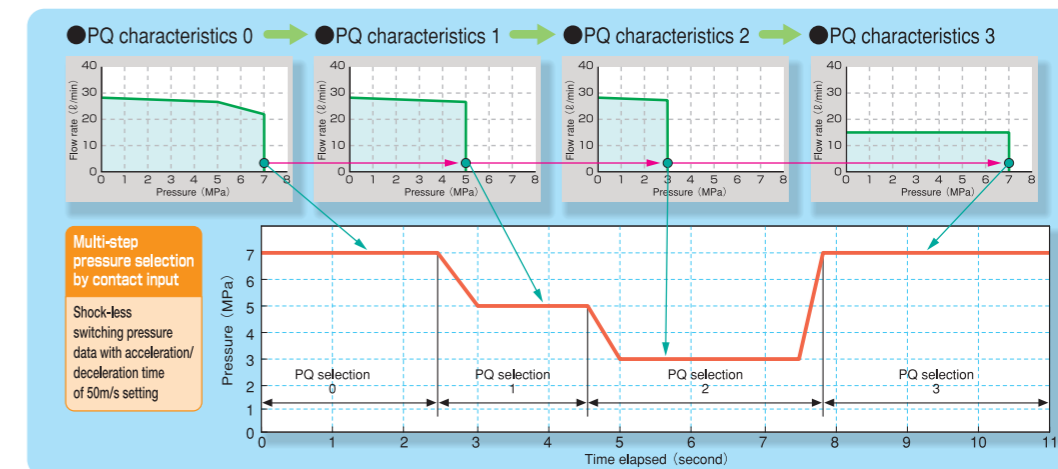

Shortened startup time upon turning on power.

The IPM motor has a reduced startup time into approximately 3 seconds, which used to be a maximum of 13 seconds in conventional system.

Extended variations of tank capacity

Variations of 10- and 20-R tank capacity have been extended. Tank capacity can be selected according to specifications.

Employment of multi-step pressure/flow rate control

By inputting 4 patterns of pressure and flow volume settings and by selecting contact signals on the machine the multi-step pressure, and flow rate are controlled easily. Shock-less adjustment is possible upon switching.

CE Standard Specification

CE standard is applicable additionally.

Optional function

Comparison in cases where a temperature rises by 10°C [Comparison between system with no temperature rise function (EHU30R-M0702) and system with temperature rise function (EHU30R-M0702T)]

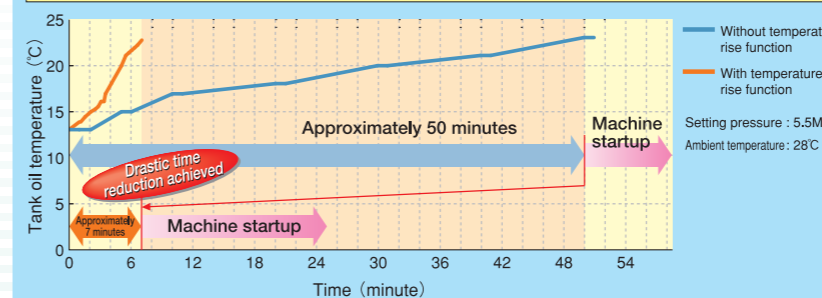

Hardware optional function

◆With terminal box : Safe and easy electrical wiring is made possible. (Refer to external dimensions view for details.)

Functional option

◆The temperature-rise function shortens standby time of the machine (main unit) by warming oil rapidly under low temperature.

The function terminates if a temperature on motor surface or on controller fin exceeds 40°C, automatically maintaining tank oil temperature at a suitable level. However, changing selection numbers of pressure (P) and flow rate (Q) is invalid if the temperature rise function is operating. Change pressure (P) and flow rate (Q) settings after a temperature has risen. A setting pressure of safety valve upon shipment is 7.5MPa.

Specifications

Tank capacity	10 l	20 l	30 l
Motor capacity	equivalent to 2.2 kW		
Max. working pressure	7.0 MPa		
Discharge adjusting range	2.5~15.2 l/min	3.5~28.5 l/min	2.5~15.2 l/min
Model	EHU15R-M0701	EHU30R-M0701	EHU40R-M07

Super Unit Single & Double pump specification

Hybrid Unit

Fusion of DAIKIN original high-efficiency IPM motor Drive system and double pump switch control technology.

First in the world

Multi-step Pressure / Flow and shock-less control by pump / motor speed control.
High performance beyond the hydraulic meets wider demands.
Tank-less type is now available. Make your unit special.

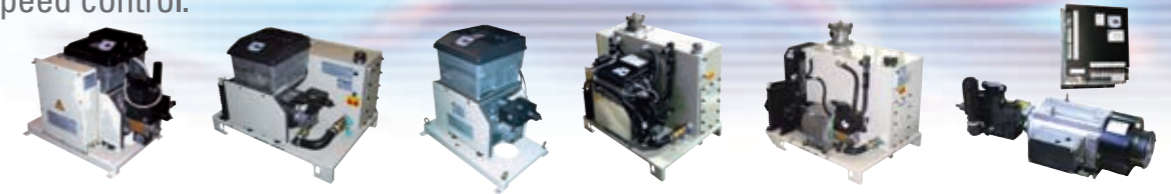

Features

POINT

1

The high-efficiency IPM motor drive system that utilizes the DAIKIN-original air conditioning motor and inverter technologies provides a high energy-saving ratio-50%.

(Double pump type in pressure holding mode at 20.6 MPa)

- By controlling the motor rotation speed, the SUPER UNIT controls the flow rate and pressure of fixed-capacity pumps. This system provides an energy-saving ratio that is at least 50% in pressure-holding mode (compared with the conventional DAIKIN variable piston pump).
- Using the high-efficiency motor, the SUPER UNIT can even provide an energy-saving effect for general industrial machinery in which actuators provide a high duty ratio, as well as in pressure-holding mode.
- The single pump type is a highly-functional series created to be more useful.
- The double pump type uses the autonomously-switching, fixed-capacity double pump system, which combines large- and small-capacity pumps in a low pressure, high flow rate range, and autonomously switches to operate the high-pressure, small-capacity pump only in the high pressure, low flow rate range. Thus, the double pump type ensures a higher energy-saving effect.

POINT

2

Four or sixteen pressure (P) - flow rate (Q) setting patterns are available for cylinder control.



- The proportional control valve and proportional pressure control valve, which are utilized in conventional actuator circuits, are not required.
- The pressure and flow rate can be set using the controller panel.
- You can select 4 or 16 pressure and flow rate setting patterns via an external input signal.
- The SUPER UNIT autonomously switches between the pressure control and flow rate control modes.

Reducing shock during flow rate or pressure changes

- Depending on the acceleration time/deceleration time settings, the SUPER UNIT can reduce shock when the flow rate or pressure is changed.

POINT

3

Low noise level-60 dB (A) (Double pump type in pressure holding mode at 20.6 MPa) The noise level is 73 dB (A) or less even in full-operation areas.

- With double phase-differential pumps, the SUPER UNIT can reduce pulsation and the noise level.

※Data for the SUT**D60L21.

POINT

4

Multi-stage P-Q remote control by communication (Function: -C)



- Using a commercially-available PLC*1 with RS-232C communication capabilities and a touch panel display, P and Q parameters, acceleration time, deceleration time, and other parameters can be set and viewed from the machine operator's side. The SUPER UNIT enables multi-stage pressure/flow rate control through remote operation.

※1: Programmable logic controller.

POINT

5

The SUT series product lineup contains products with various capacities, from 7.0 MPa and 1.5 L/min to 20.6 MPa and 110 L/min. Furthermore, "pump & motor type" and "unit type" are selectable. Thus, the SUPER UNIT can flexibly meet almost any user's needs.

- The SUPER UNIT offers wide applications for machine tools and general industrial machinery such as press.

High Performance

4 to 16 patterns pressure/flow set values with input signal selection from the main machine side make it easy to attain multi-step pressure and flow rate control. Shock-less control in selecting can be available.

●PQ characteristic 0 ●PQ characteristic 1 ●PQ characteristic 15 ●PQ characteristic 16

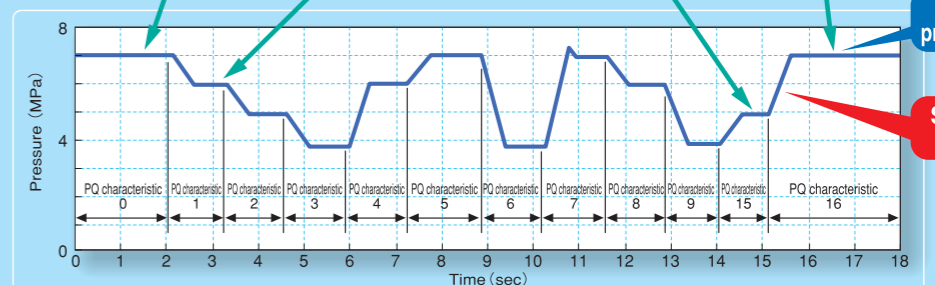
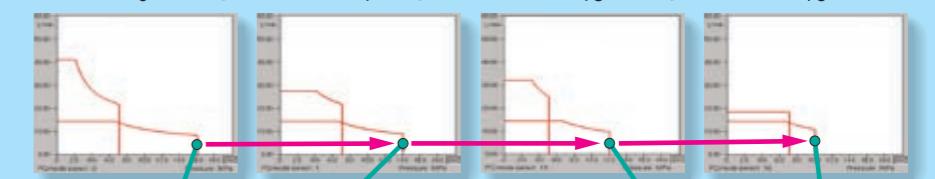

Staged pressure by contact input
(Data of shock-less pressure select at acceleration/deceleration set value of 50 ms)

- High-efficiency IPM motor drive system
- Autonomous select type fixed tandem pump

- Flow combining/dividing selection can be autonomously controlled according to load pressure with tandem pump of fixed displacement (high and low) and selector. If high speed is needed, two high- and low-displacement pumps are combined to rotate at high speed to discharge at higher flow rate. When the pressure is retained, only the low-displacement pump is selected to operate at low speed to save energy greatly.

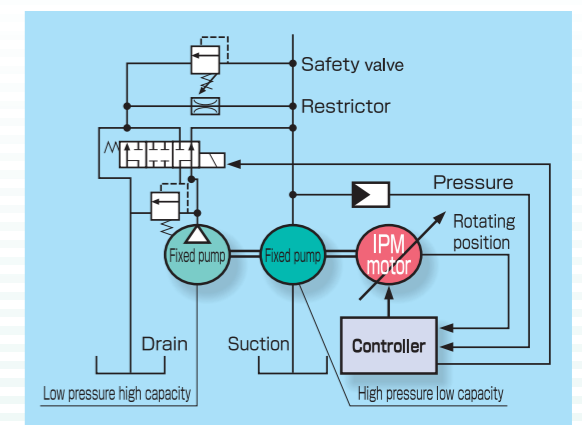

Remote control of multi-step Pressure/flow by M-code (Function: -C,-D for SUT-S series)

- ◆With commercial PLC(*1) with RS232C communication function, touch-panel display, and others on the machine side; Pressure/flow, acceleration/deceleration time, and other parameters can be set and displayed. Accordingly; remote control of Multi-step Pressure/flow, monitoring pressure, and others can be also available.

Super Unit

Single & Double pump specification

Hybrid Unit



Simplification of system

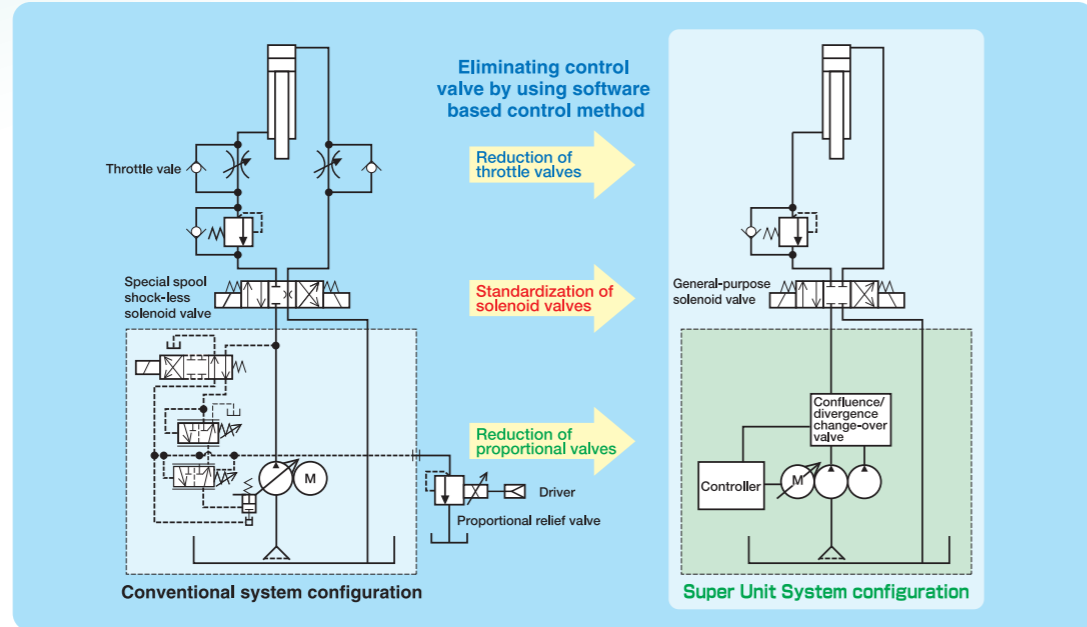

- Pressure and flow rate (PQ) characteristics of 4 or 16 patterns are preset to the control unit. Select and input them on the main machine side, and Multi-step pressure and flow rate control can be easily attained.
- Adjust select rise/fall time in selecting PQ characteristics, and shockless control can be attained.
- The conventional valve control is replaced by pump control; and simple and low-cost systems can be produced for high/low press speed select and Multi-step pressure control.

Energy saving

Fusion of DAIKIN original high-efficiency IPM motor drive system and tandem pump selecting control technology provides epoch-making energy saving effects.

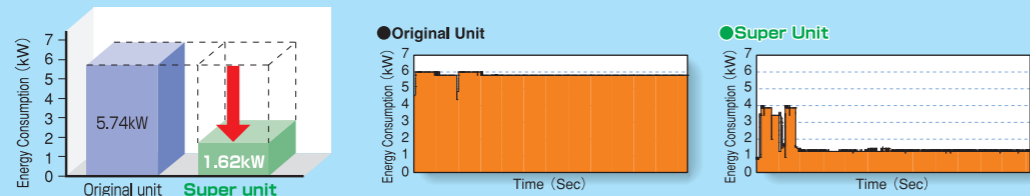

Energy saving of 50% (at pressure retained at 20.6 MPa) is attained to give high cost performance.

- ◆ Air conditioning motor inverter technology and tandem pump selecting control technology are fused to attain high energy saving effects.
- ◆ Not only at pressure retained but in the field of general industrial machinery where actuators are frequently operated, such a high-efficiency motor can save energy greatly.

Low noise: 60 dB (A) (20.6 MPa at pressure retained)

Low noise 60 dB (A) (20.6 MPa at pressure retained) attained. In all of the operation area, the noise is 70 dB (A) or less.

- ◆ The phase-differential tandem pump attains low pulsation and low noise.

Simplification of system



The SUPER UNIT and main machine can be remotely controlled with the same panel. This function eliminates complicated individual operations and installation space limitations.

- ◆ Remote operation and monitor display are enabled by serial communication (conforming to RS-232C).

Remote operation and monitor display are enabled by serial communication (conforming to RS-232C). The SUPER UNIT controller is equipped with an operation panel, allowing you to change parameter settings and monitor the pressure and flow rate. To change a parameter or monitor the pressure/flow rate from the machine (main machine) side, use a communication function-equipped hydraulic unit. (Refer to the model list on p. 5.) Serial communication (conforming to RS-232C)

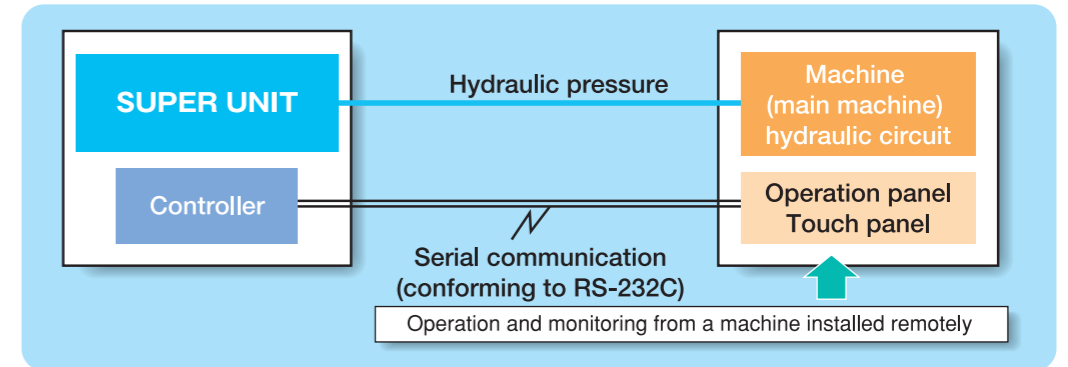

- ◆ The pressure and flow rate can be constantly monitored.

By monitoring the pressure and flow rate, centralized control of process data is enabled. An additional pressure gauge is not required. (Communication is enabled using a commercially-available touch panel and PLC with an RS-232C interface.)

- ◆ Parameter settings can be changed.

With the communication function, the pressure and flow rate can be constantly monitored from the main machine side. The pressure and flow rate settings can also be changed from the main machine side.

※ For details about the communication function, refer to the communication function instruction manual.

Specifications

● Single pump specification

Tank capacity	30 l				60 l	100 l			
Motor capacity	Equivalent to 2.2kW	Equivalent to 2.8kW	Equivalent to 3.7kW		Equivalent to 5.0kW	Equivalent to 7.0kW			
Max working pressure	7.0 MPa	10.0 MPa	7.0 MPa	7.0 MPa	10.0 MPa	16.0 MPa	7.0 MPa		
Discharge adjusting range (l/min)	2.5~15.2	3.5~28.5	5.2~61.1	3.4~25.6	2.4~15.2	3.4~25.6	8.7~65.4	11.6~86.8	
Model	STU03S15L07-F,-C	STU03S15L10-F,-C	STU03S30L07-F,-C	EHU40R-M07-10	STU03S30L10-F	STU03S15L16-F	STU03S30L16-F	STU06S60L07-F	STU10S80L07-F,-C
Pump & Motor Type	SUT00S1507-F,-C	SUT00S1510-F,-C	SUT00S3007-F,-C	SUT00S4007-F	STU00S30L10-F	STU00S1516-F	STU00S316-F	STU00S6007-F	SUT00S8007-F,-C

● Double pump specification

Tank capacity	60 l	100 l	60 l	100 l	100 l	160 l	0 l
Motor capacity	Equivalent to 3.7kW		Equivalent to 5.0kW		Equivalent to 7.0kW		Equivalent to 11.0kW
Max working pressure	15.7 MPa			20.6 MPa			
Discharge adjusting range (l/min)	5.4~41.0		8.7~61.1		11.6~83.0		13.3~110
Unit Type Model	STU06D40L16-F	STU10D40L16-F	STU06D60L21-F	STU10D60L21-F	STU10D80L21-F,-C	STU16D80L21-F,-C	—
Pump & Motor Type Model	SUT00D4016-F		SUT00D6021-**-F		SUT00D8021-**-F,-C		SUT00D11021-**-F,-C

Intelligent Coolant Pump

Coolant Pump

Optimum flow rate is given by controlling motor rotating speed

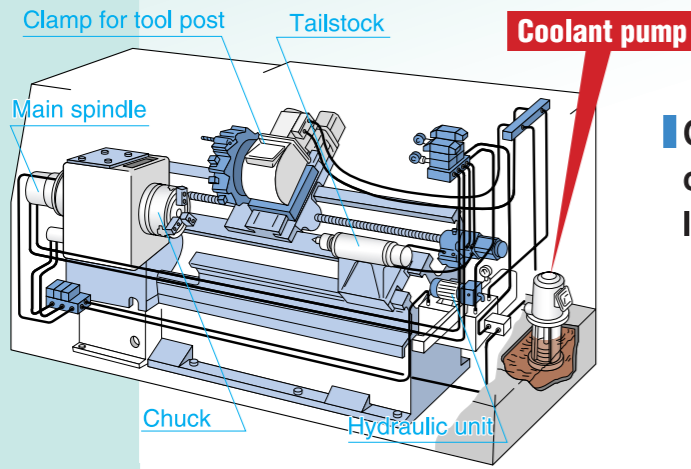

Coolant pump is used to spray coolant oil on work and tools for cooling, lubrication and removing chips.

Market demand

Big end users using many machines need to reduce energy consumption, especially automobile manufacturers, automobile parts manufacturers.

- Generally, coolant pumps occupy about the half of the power consumptions by machines. Higher energy saving effects can be expected.
- Generally valves are used to adjust the quantity of coolant, which consumes much energy. Wasted energy can be reduced by controlling the pump rotating speed to supply optimum coolant.

Breakdown of power consumption in machining line

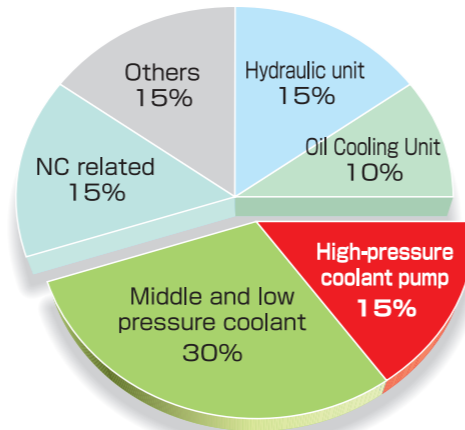

Energy saving

- ◆ The power consumption cannot be sharply reduced only by restricting with the valve to control the quantity of coolant.
- ◆ Adjust the rotating speed to reduce the quantity, and the power consumption can be reduced greatly. As shown in the right figure; reduce the quantity pumped up by 20%, and the power consumption can be reduced by 40%.

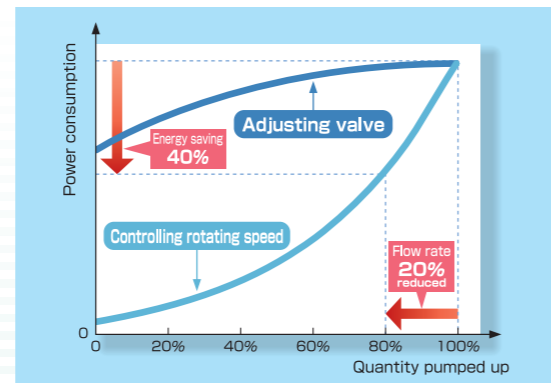

Conventional system

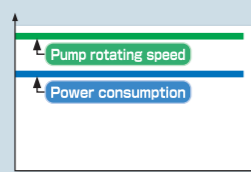

Reduction of Flow

The appropriate amount of coolant is supplied by means of rotation speed control without throttle valve.

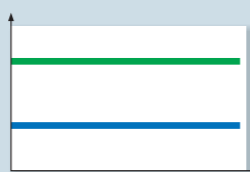

Flow reduction + Intermittent operation

For clearing away of chips, no such constant cleaning-away is required; even intermittent control can reduce power.

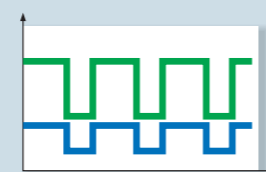

If you reduce 20% flow rate, the energy is reduced 40%

Moreover, if 50% intermittent operation is carried out at 70% duty, the initial energy consumption can be reduced by 53%

Easy setting

- ◆ Control unit and pump are united into a system, and it can be installed in any place. No wiring is required.
- ◆ Intelligent Coolant Pump includes energy-saving operation mode. Select the mode and input the contact signal only. No complicated sequences are needed.

1	Normal operation mode (Reduced flow rate)
2	Intermittent operation mode
3	2-flow rate mode
4	Pressure control mode

Compact system and simple energy saving

- ◆ Multiple pumps can be integrated into a high-displacement pump with switching valves as a compact system.
- ◆ Pressure control automatically adjust the head range. When some oil supply points are selected, rotating speed is automatically adjusted to supply the required quantity. Energy saving can be attained easily.

Minimized flow change

- ◆ Nozzle tip pressure is controlled constantly. When cutting oil supply points to the work are selected, no supply positions are not changed. Accordingly, no process defectives are detected.

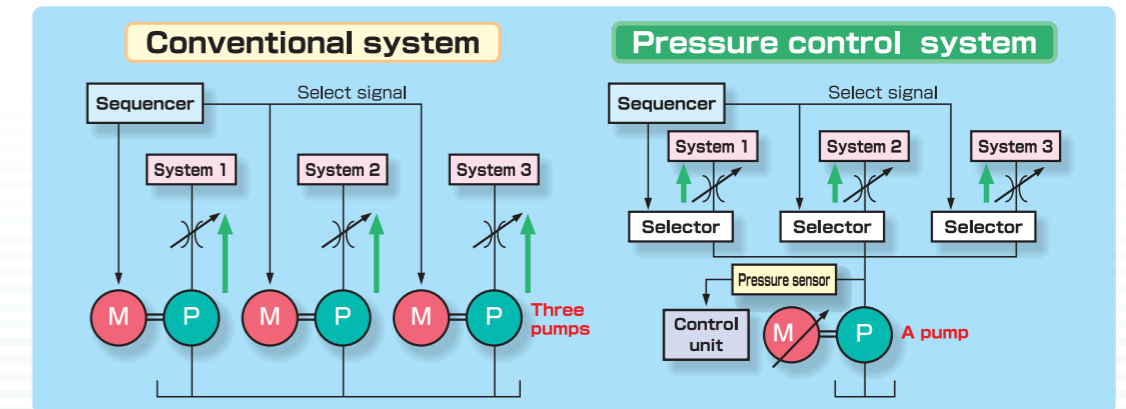

Specifications

Rotating speed control

Motor input	0.9 kW	1.6 kW	1.5 kW	2.6 kW	2.3 kW
Discharge	20~75 l/min		50~170 l/min		100~300 l/min
Model	ECP02-6-3-10	ECP02-6-6-10	ECP04-6-3-10	ECP04-6-6-10	ECP08-3-3-10

Pressure control

Motor input	0.9 kW	1.6 kW	1.5 kW	2.6 kW	2.3 kW
Discharge	10~75 l/min	10~90 l/min	25~170 l/min	25~190 l/min	50~280 l/min
Model	ECP02-6-3-10-P	ECP02-6-6-10-P	ECP04-6-3-10-P	ECP04-6-6-10-P	ECP08-3-3-10-P

Intelligent High-Pressure Coolant Pump

High-pressure Coolant Pump

Autonomous type pressure-flow rate control system, which reduces the excessive flow from the relief valve to zero. Energy saving of 40% attained.

DAIKIN original high-efficiency IPM motor drive adopted. Pump rotating speed control and stand-by signal function save power consumption greatly (40%) at process facilities.



Market demand

● Big end users, such as automobile manufacturers, automobile parts manufacturers, and electric parts manufacturers have increasingly requested to save energy at their process facilities.

Power consumption by coolant pump

● Generally, coolant pumps of middle-and high-pressure types occupy about the half of the power consumptions by machines. Fixed displacement pump is used as high-pressure coolant pump generally. All of the excessive flow is drained from the relief valve. Actually, only one coolant pump consumes 15% of the power consumption by process facilities. As the result, not only much energy is consumed but additional equipment cost is needed.

Energy saving effect

● New High-Pressure Coolant Pump (ECPH series) reduces 40% power consumption comparing with the conventional coolant pump, which shared 15% of the power consumption at process facilities. It contributes to energy saving at factories greatly.

Breakdown of power consumption in machining line

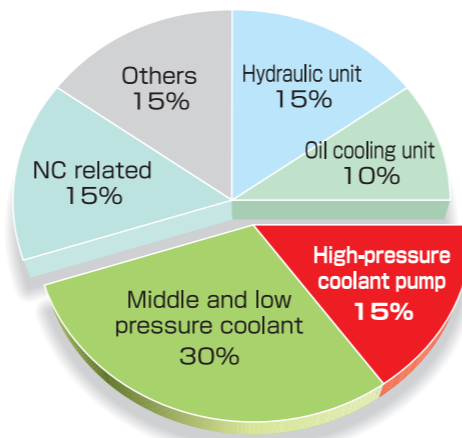

"Soft start function" is included to start the pump smoothly. Life of bearings can be extended.

Soft start function

When the conventional coolant pump repeats "Pump stop → Start" or "Unload → Load", life of bearing is remarkably shortened due to low-viscosity cutting fluid. Intelligent High-Pressure Coolant Pump is equipped with "Soft start function" to start the pump smoothly. The upper spindle has been greatly improved in reliability.

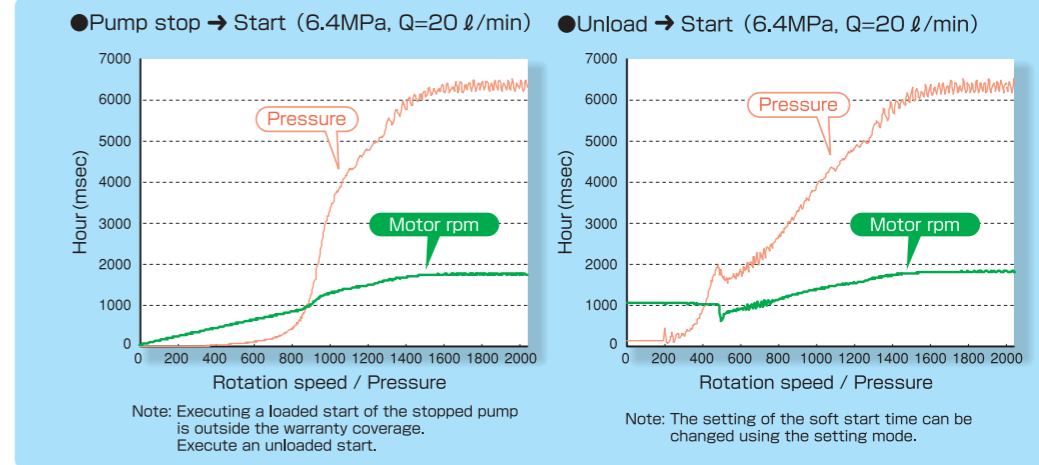

Energy saving

The Pump is equipped with DAIKIN original high-efficiency IPM motor drive to attain the energy-saving effect of 40%.

Zero excessive flow from relief valve.

First in the world

High-Pressure Coolant Pump (ECPH series) is first equipped with "autonomous type pressure-flow rate control" which is given actual results with ECORICH. The excessive flow from the relief valve is reduced to zero by controlling pump rotating speed. Power consumption is greatly reduced.

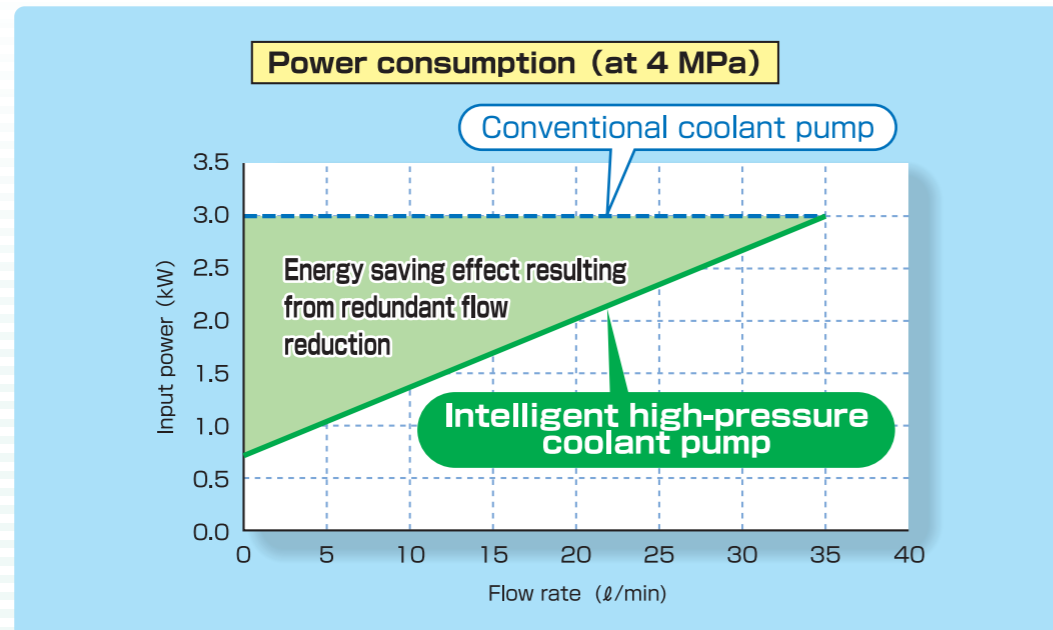

System configuration

With DAIKIN original high-efficiency IPM motor drive, optimum quantity of coolant can be supplied by controlling pump rotating speed. The excessive flow from the relief valve can be reduced to zero, which results in great reduction of power consumption. The stand-by signal can select Start/Stop. If unnecessary, the motor can be stopped and the energy-saving effect can be much improved.

The discharge pressure can be set. The pump rotating speed is automatically controlled to keep the pressure at the set value if the oil wheel diameter varies.

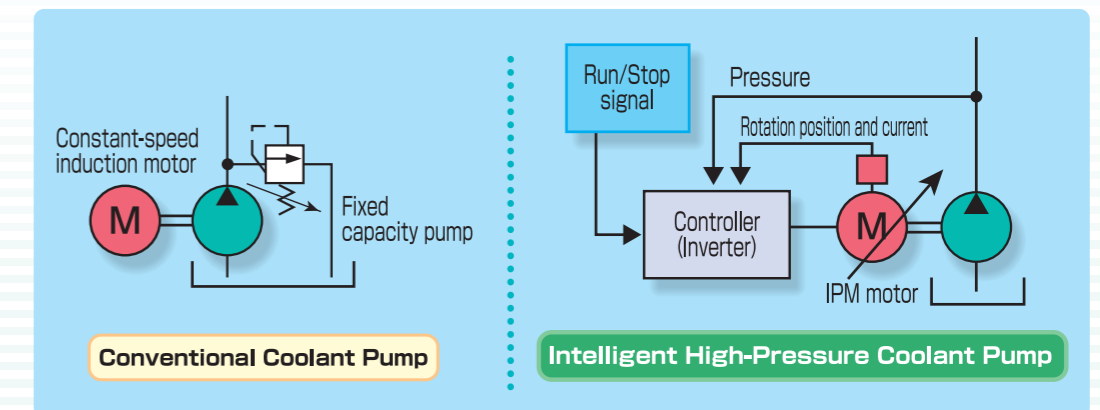

Specifications

Flow rate	28 l/min	20 l/min	14 l/min
Pressure	4.4 MPa	5.9 MPa	6.9 MPa
Model	ECPH20-045-10	ECPH16-060-10	ECPH13-070-10

Oil Cooling Unit

Amazingly improved energy-saving inverter Oil Cooling Unit, equipped with DAIKIN original high-efficient IPM motor for air conditioners.



Why machine tools require Oil Cooling Unit?

Latest machine tools demand

High-speed rotation: Improving surface roughness and accuracy

● Heat is generated at headstock bearings and gears. The entire main spindle is warmed and the spindle deviates from the center of the column and the head, which results in poor accuracy. It is because there are differences in temperature among machine parts. Oil Cooling Unit can control temperature at the headstock, and the deviation can be corrected. Oil Cooling Unit lubricates the headstock gears and removes the heat generated. It is helpful to improve machine accuracy. (AKZ8 series)

Increased machining accuracy of work and extension of tool life

● Highly accurate processing can be attained by controlling temperature of cutting and grinding fluids. In addition, longer tool life can be attained and deterioration of coolant can be reduced. Oil Cooling Unit contributes to improve machine operation efficiency. (AKZJ8 series)

Controlling oil temperature to optimum value according to heat generation of main machine

● Oil Cooling Unit compressor frequency valuable control gives appropriate cooling capacity according to the heat generated on the main machine side to meet the operating condition. The fluid temperature can be controlled accurately depending on load fluctuation from lowest to highest. Unlike the conventional non-inverter Oil Cooling Unit, the cooling capacity can be controlled in a wider range. Not only inlet fluid oil temperature control; but outlet fluid oil temperature control, return fluid oil temperature control, room temperature tuning, machine temperature tuning, and other operation modes can be selected according to the conditions of main machine.

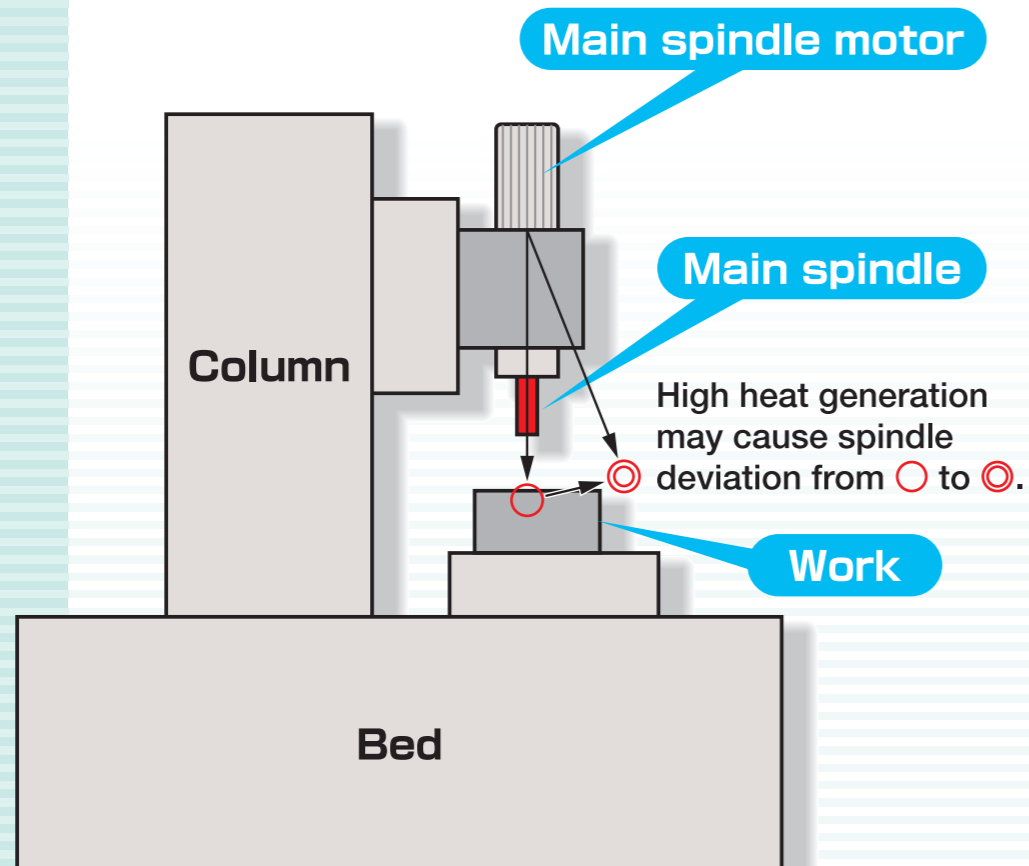

Application

Application examples

Main machines (Machine tools, Industrial machinery) are as follows:

- ◆ Machine tools : Machining center, NC lathe, Grinding machine, NC special-purpose machine, NC electric discharge machine, etc.
- ◆ Industrial machinery : Molding machine, Press, etc.

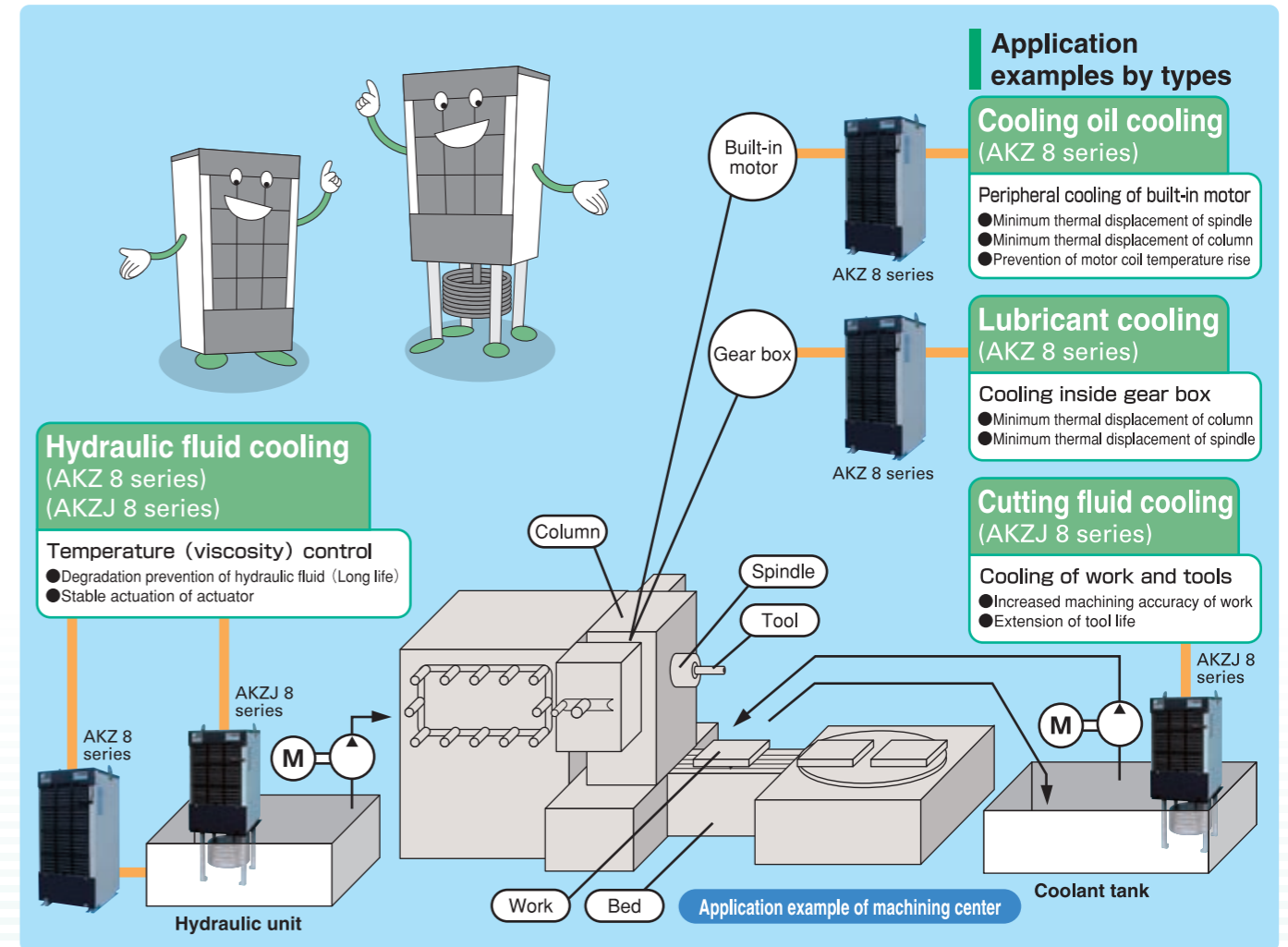

Specifications

Oil Cooling Unit equivalent horsepower	0.5 HP		1.2 HP		1.5 HP		2.0 HP	3.0 HP
Cooling capacity (50/60 Hz)	1.3/1.4 kW	1.6/1.8 kW	2.8/3.2 kW	3.2/3.5 kW	3.8/4.3 kW	4.2/4.5 kW	5.0/5.6 kW	8.0/9.0 kW
Circulation type	AKZ148	—	AKZ328	—	AKZ438	—	AKZ568	AKZ908
Immersion type	—	AKZJ188	—	AKZJ358	—	AKZJ458	AKZJ568	AKZJ908

Oil Cooling Unit



High-accuracy temperature control

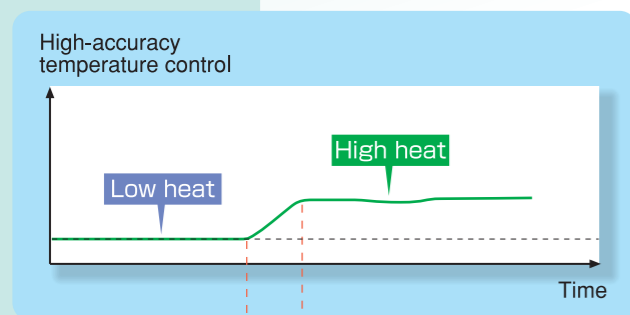

Conventional ON/OFF controlled (AKS5 series)

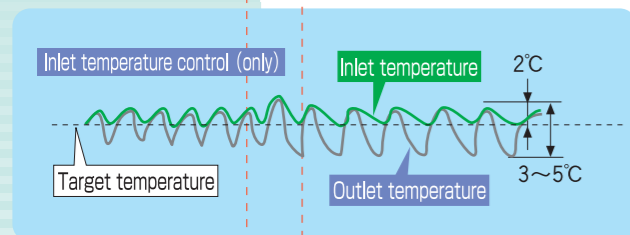

New inverter controlled (AKZ8 series)

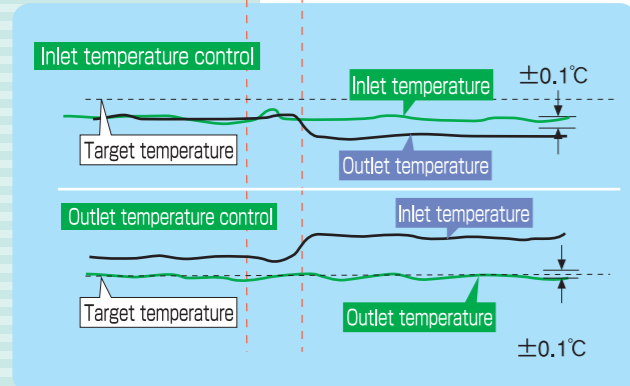

Note) Stabilized condition at 5~100% heat load (in comparison with our conventional products)

The inverter-controlled unit keeps the best machine operation conditions at any time to improve the machining accuracy.

The first class energy saving

DAIKIN original IPM motor and new refrigerant R410A provide the first class energy saving.

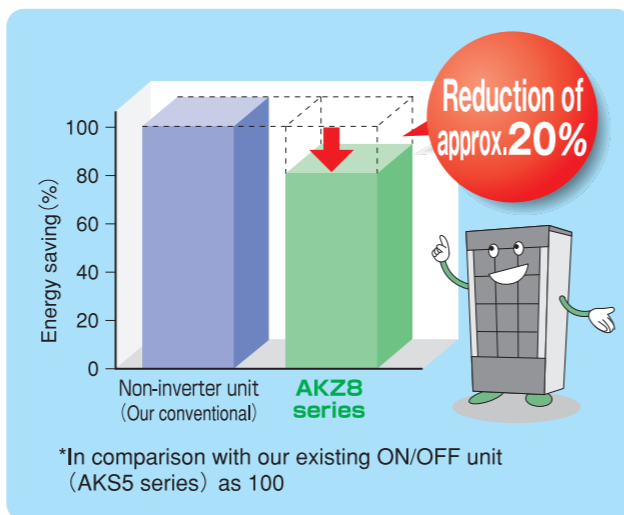

The smallest size in the industry

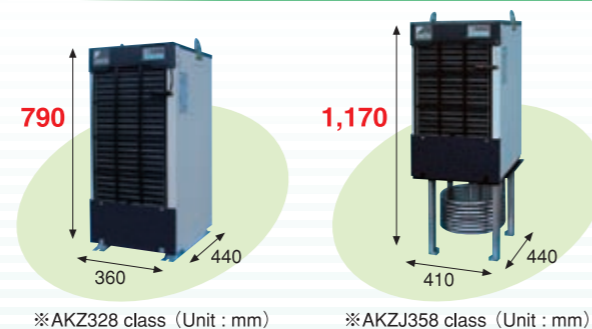

Low noise

68dB (A) → 62dB (A) with AKZ1.2HP class, corresponding value in anechoic chamber

Generally, people can talk at the distance of 1m at the noise level of 60 dB(A).



New refrigerant

New refrigerant (R410A) adopted, which may not destroy the ozone layer.

0.5 MPa relief pressure standardized (AKZ3 series)

0.3 MPa for conventional unit,

→ Piping pressure loss problem solved

Low-viscosity pump standardized (AKZ3 series)

Viscosity of oil : 1.4~200mm²/s

The shortest delivery, 4-5 type specifications available in addition to the standard model

All optional specifications are listed as semi-standard.

Oil heater, Oil tank, Different voltage specifications, Circuit breaker, CE specifications

AKZ : 5 types

AKZJ : 4 types

New useful functions added to current oil temperature warning functions

Auto tuning function

◆ Only operate main machine at no load for 10 - 20 minutes, and temperature control gain is set automatically. The tuning time during test run can be greatly shortened.



Refrigerant gas leakage detection function

◆ Alarm signal is output at the time of refrigerant gas leak (cooling failure). Burn-out of spindle can be indirectly prevented.



99-hour timer function

◆ Max. 99-hour warming up can be easily performed.

Capacity Chart

Hydraulic unit	Model (Unit Type)	Model (Pump & Motor Type)	Max. operating pressure(MPa)							Max. flow rate(ℓ/min)											Tank capacity(ℓ)						Select function					
			4.0	6.0	7.0	10.0	15.7	16.0	20.6	14	15.2	25.6	28.5	30	40	41	61.1	83	110	10	20	30	60	100	160	DCL+ NF*1	4- stage PQ	16- stage PQ	Communi- cation			
			●	●	●	●	●	●	●	●	●	●	●	●	●	●	●	●	●	●	●	●	●	●	●	●	●	●	●			
	EHU14-L04-A-30		●																●						●							
	EHU25-L04-A-30		●																	●						●						
	EHU25-L07-AE-30		●	●	●															●						●						
	EHU25-M07-AE-30		●	●	●															●						●						
	EHU30-M07-AE-30		●	●																●						●						
	EHU15R-M0701		●	●	●															●						●	●					
	EHU15R-M0702		●	●																	●	●					●	●				
	EHU30R-M0701		●	●	●																●						●	●				
	EHU30R-M0702		●	●	●																●	●					●	●				
	EHU40R-M07-A-10	SUT00S4007-10-F	●	●	●								●	●	●							●					●	●				
	SUT03S15L07-10-F	SUT00S1507-10-F	●	●	●																	●				●						
	SUT03S15L07-10-C	SUT00S1507-10-C	●	●	●																		●				●		●			
	SUT03S30L07-10-F	SUT00S3007-10-F	●	●	●																		●				●					
	SUT03S30L07-10-C	SUT00S3007-10-C	●	●	●																		●				●					
	SUT03S15L10-10-F	SUT00S1510-10-F	●	●	●	●																	●				●					
	SUT03S15L10-10-C	SUT00S1510-10-C	●	●	●	●																	●				●					
	EHU40R-M07-A-10	SUT00S4007-10-F	●	●	●								●	●	●								●				●	●				
	SUT03S30L10-10-F	SUT00S3010-10-F	●	●	●	●																	●				●					
	SUT03S15L16-10-F	SUT00S1516-10-F	●	●	●	●	●	●	●														●				●					
	SUT-06S30L16-20-F	SUT00S3016-10-F	●	●	●	●	●	●	●															●				●				
	SUT06S60L07-20-F	SUT00S6007-10-F	●	●	●								●	●	●	●	●	●						●				●				
	SUT10S80L07-10-F	SUT00S8007-10-F	●	●	●								●	●	●	●	●	●	●					●				●				
	SUT10S80L07-10-C	SUT00S8007-10-C	●	●	●								●	●	●	●	●	●	●					●				●		●		
	SUT06D40L16-20-F	SUT00S4016-10-F	●	●	●	●	●	●																●				●	●			
	SUT10D40L16-20-F	SUT00D6021-10-F	●	●	●	●	●	●																●				●	●			
SUT06D60L21-20-F	SUT00D6021-10-F	●	●	●	●	●	●	●	●															●				●	●			
SUT10D60L21-20-F	SUT00D8021-10-C	●	●	●	●	●	●	●	●															●				●	●			
SUT10D80L21-10-C	SUT00D8021-10-C	●	●	●	●	●	●	●	●															●				●	●			
SUT16D80L21-10-C	SUT00D11021-20(21)-F	●	●	●	●	●	●	●	●															●				●	●			
—	SUT00D11021-20(21)-C	●	●	●	●	●	●	●	●																●				●	●		

*1) DCL+NF: with DC reactor and noise filter

Coolant pump	Model	Total head (m)	Pressure (MPa)	Flow rate(ℓ/min)																											
				2	6	10	14	20	25	28	33	50	75	90	100	170	190	280	300												
	ECP02-6-3-10-(F/B/L/R)	35~10						●	●	●	●	●	●																		
	ECP02-6-6-10-(F/B/L/R)	70~30						●	●	●	●	●	●																		
	ECP04-6-3-10-(F/B/L/R)	38~10												●	●	●	●	●	●												
	ECP04-6-6-10-(F/B/L/R)	75~27												●	●	●	●	●	●												
	ECP08-3-3-10-(F/B/L/R)	42~13																		●	●	●	●	●	●	●	●	●	●	●	
	ECP02-6-3-10-(F/B/L/R)-P	30~10													●	●	●	●	●	●											
	ECP02-6-6-10-(F/B/L/R)-P	60~10													●	●	●	●	●	●											
	ECP04-6-3-10-(F/B/L/R)-P	30~10																			●	●	●	●	●	●	●	●	●	●	●
	ECP04-6-6-10-(F/B/L/R)-P	70~10																				●	●	●	●	●	●	●	●	●	●
ECP08-3-3-10-(F/B/L/R)-P	30~10																					●	●	●	●	●	●	●	●	●	
	ECPH20-045-10		4.4					●	●	●	●	●	●																		
	ECPH16-060-10		5.9					●	●	●	●	●	●																		
	ECPH13-070-10		6.9					●	●	●	●	●	●																		
	ECPH20-045-10-F		4.4					●	●	●	●	●	●																		
	ECPH16-060-10-F		5.9					●	●	●	●	●	●																		
	ECPH13-070-10-F		6.9					●	●	●	●	●	●																		

Specification List

ECORICH



Specifications

Model	EHU14-L04	EHU25-L04	EHU25-L07	EHU25-M07	EHU30-M07
Tank capacity (ℓ)	10				
Motor capacity (Nominal)	Equivalent to 0.75 kW	Equivalent to 1.5 kW	Equivalent to 2.2 kW	Equivalent to 2.8 kW	
Max operating pressure (MPa)	4.0		7.0		6.0
Pressure adjustment range*Note 1 (MPa)	1.5~3.5		1.5~7.0		1.5~6.0
Discharge rate adjustment range*Note 2 (ℓ/min)	4~14	5~25		5~28.5	
Weight (kg)	43		45	46	
Capacity of fan motor for oil cooler	16/15W (50/60 Hz)				
Power supply	Motor for pump	3-phase 200/200-220V AC, 50/60Hz Allowable POWER fluctuation ±10%			
	Oil-cooler Fan Motor	2-Phases 200/200/220V, 50/60/60H (supported by the controller)			
Alarm output relay	DC12/24 V AC100V (50/60Hz) The Max. Load Current : Below 1A (resistance load)				
Standard painted color	Black				
Usable oil *Note 3	Mineral oil based special hydraulic fluid/Abrasion resisting hydraulic fluid For recommended brands, refer to our "Hydraulic Equipment General Catalog (HK196A)". ·Viscosity grade :ISO VG32~68 ·Viscosity range :15~400mm ² /s (20~200 mm ² /s recommended) ·Contamination :Class NAS9 or lower				
Tank oil temperature	0 ~ 60 °C (Recommended : 15 ~ 50 °C)				
Ambient temperature	0 ~ 35 °C				
Ambient humidity	85% RH or lower				
Installation place	Indoors (Fix with bolts without fail.)				
Others	The no fuse breaker and an earth leakage breaker must be used.				

Note) *1: The pressure is preset to be max pressure when delivered.
*2: It is preset to be the Max. Discharge Rate when delivered. (the Max. Discharge Rate is a theoretical value but not an exact one.)
*3: Other fluid (ex. water and glycol) than mineral oil base hydraulic fluid (hydrous or synthetic) can not be used.

Nomenclature



- | | |
|---|---|
| <p>1 Basic
EHU : ECO-RICH EHU series</p> <p>2 Pump maximum flow rate
14 : 14 ℓ/min
25 : 25 ℓ/min
30 : 28.5 ℓ/min</p> <p>3 Output characteristic
L : —
M : —</p> <p>4 Maximum operating pressure
04 : 4.0 MPa
07 : 7.0 MPa</p> | <p>5 Control system
A : Pressure compensated control</p> <p>6 Specifications of control unit
No symbol : With reactor
(In case of EHU14 (25) -L04)
E : With reactor
(In case of EHU25-L07, M07, EHU30-M07)</p> <p>7 Design No.
10 : EHU40R-M07
May change according to model change.</p> <p>8 Non-standard No.
No symbol : Standard</p> |
|---|---|

ECORICH-R

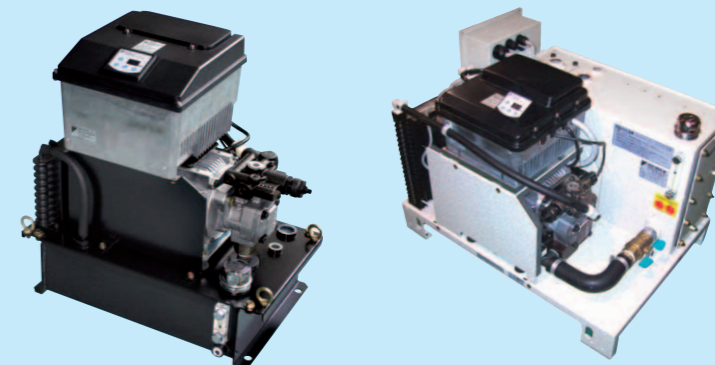

Specifications

Model	EHU15R-M0701	EHU15R-M0702	M30R-M0701	EHU30R-M0702	EHU40R-M07-A
Tank capacity (ℓ)	10	20	10	20	30
Motor capacity (Nominal)	Equivalent to 2.2 kW		Equivalent to 2.8 kW		Equivalent to 3.7 kW
Max operating pressure (MPa)	7.0				
Pressure adjustment range (MPa)	0.5~7.0				1.5~7.0
Discharge rate adjustment range (ℓ/min)	2.5~15.2		3.5~28.5		5.3~40.0
Weight (kg)	39	40	41	42	68
Power supply	Motor for pump	3-phase 200/200-220V AC, 50/60Hz (Allowable power fluctuation ±10%)			
	AC fan motor	1-phase 200/200-220V AC, 50/60Hz (Supplied by controller)			
External input signal	3 points, Photocoupler insulation, DC 24V (Max. 27V) 5mA/1ch				
External output signal	Digital output (2ch)	Photo coupler insulation, open collector output, DC 24V 50mA Max/1ch			
	Point of contact output (1ch)	Relay output: Contact capacity 30V DC, 0.5A(Resistance load) 1ch contact			
Retard current	200V/50Hz	7.9A	10.9A		11.2A
	200V/60Hz	7.7A	10.7A		10.9A
	220V/60Hz	7.1A	9.7A		10.0A
Standard painted color	Black				
Usable oil *Note 1	Mineral oil based special hydraulic fluid/Abrasion resisting hydraulic fluid For recommended brands, refer to our "Hydraulic Equipment General Catalog (HK196A)". ·Viscosity grade :ISO VG32~68 ·Viscosity range :15~400mm ² /s (20~200 mm ² /s recommended) ·Contamination :Class NAS10 or lower				
Tank oil temperature	0~60 °C (Recommended operating temperatures : 15 ~ 50 °C)				
Ambient temperature	0~35°C				
Ambient humidity	85% RH or lower				
Installation place	Indoors (Fix with bolts without fail.)				
Sea level	1,000m or lower				

Note) *1: Other fluid (ex. water, glycol) other than mineral oil based hydraulic fluid (hydrate/synthetic) can not be used.

Nomenclature



- | | | |
|--|--|--|
| <p>1 Basic
EHU**R : EcoRich R (IPMinstalled)</p> <p>2 Pump maximum flow rate
15 : 15.2 ℓ/min
30 : 28.5 ℓ/min</p> <p>3 Maximum operating pressure
M07 : 7.0MPa</p> | <p>4 Tank capacity
01 : 10 ℓ
02 : 20 ℓ</p> <p>5 Hardware option
No symbol : Standard
B : with terminal box</p> | <p>6 Function option
No symbol : Multi-step pressure / flow rate control function
4-pattern pressure
T : Flow rate control</p> <p>7 Design No.
May change according to model change.</p> <p>8 Non-standard graduated number</p> |
|--|--|--|

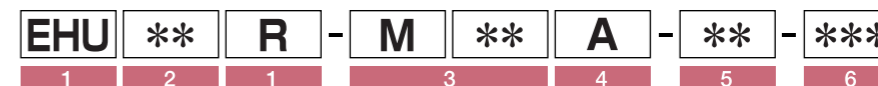

- | | | |
|--|--|--|
| <p>1 Basic
EHU**R : EcoRich R (IPMinstalled)</p> <p>2 Pump maximum flow rate
40 : 40.0 ℓ/min</p> | <p>3 Maximum operating pressure
M07 : 7.0MPa</p> <p>4 Control mode
A : Pressure compensation control</p> | <p>5 Design No.
May change according to model change.</p> <p>6 Non-standard graduated number</p> |
|--|--|--|

Specification List

Super Unit Single pump specification



Single pump specification

Model	SUT03S 15L07-10-F	SUT03S 1507-10-C	SUT03S 15L10-F	SUT03S 15L10-10-C	SUT03S 30L07-10-F	SUT03S 30L70-10-C	SUT03S 30L10-10-F	SUT03S 15L16-10-F	SUT03S 30L16-20-F	SUT06S 60L07-10-F	SUT10S 80L07-10-F	SUT10S 80L07-10-C
Max. flow rate (Theoretical value) (ℓ/min)	15.2				28.5		25.6	15.2	25.6	61.1	83.0	
Max. operating pressure (MPa)	7.0	10.0		7.0	10.0	16.0		7.0				
Tank capacity (ℓ)	30				60		100					
Pressure control range (MPa)	1.5~7.0	1.5~10.0		1.5~7.0	1.5~10.0	1.5~16.0		1.5~7.0				
Discharge control range (ℓ/min)	2.5~15.2		3.5~28.5		3.4~25.6	2.4~15.2	3.4~25.6	8.7~61.1	11.6~83.0			
Power supply	Motor pump 3-phase 200/200-220V AC, 50/60Hz (Allowable power fluctuation ±10%)											
External input signal	Photocoupler insulation DC 24V (Max. 27V) 5mA/1ch Minus common											
External output signal	Digital output (2ch) 2 point, Photocoupler insulation, Open corrector output, DC 24V 30mA or less/1ch											
	Point of contact output (1ch) 1 point, (1c contact), Contact capacity DC30V 0.5A, Resistance load, 1c contact											
Usable oil	Mineral oil based special hydraulic fluid/Abrasion resisting hydraulic fluid ·Viscosity grade : ISO VG32~68 ·Viscosity range : 15~400mm ² /s (20~200mm ² /s recommended) ·Contamination : Class NAS9 or lower											
Tank oil temperature	0~60°C (Recommended : 15~40°C)											
Ambient temperature	0~35°C											
Ambient humidity	20~85% RH or lower											
Installation place	Indoors (Fix with bolts without fail.)											
Weight (kg)	65	67		68	60	99	134					

* Preset to max. discharge. The above max. discharge value is not a guaranteed value, but a theoretical value.
* Other fluid (ex. water, glycol) than mineral oil based hydraulic fluid (hydrate/synthetic) can not be used.
* The weight excludes hydraulic oil.

Super Unit Double pump specification

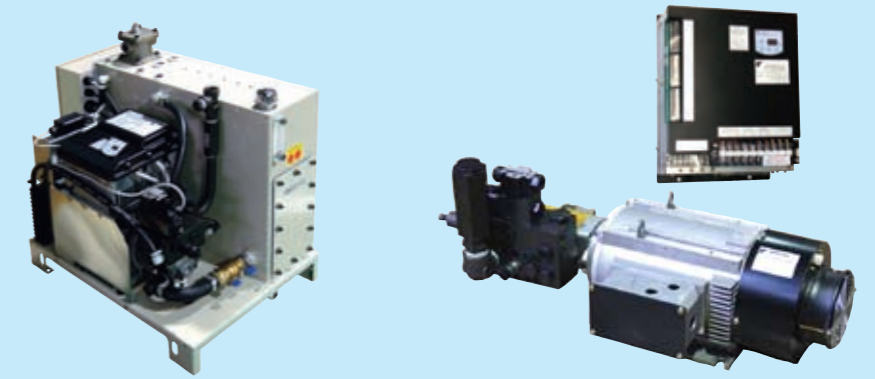

Double pump specification

Model	SUT06D 40L16-20-F	SUT10D 40L16-20-F	SUT06D 60L21-20-F	SUT10D 60L21-20-F	SUT10D 80L21-10-F	SUT16D 80L21-10-F	SUT10D 80L21-10-C	SUT16D 80L21-10-C	SUT00D 11021-21-F	SUT00D 11021-21-C
Max. flow rate (Theoretical value) (ℓ/min)	41.0		61.1		83		110			
Max. operating pressure (MPa)	15.7		20.6		20.6					
Tank capacity (ℓ)	60	100	60	100	100	160	100	160	Pump & Motor Type	
Pressure control range (MPa)	1.5~15.7		1.5~20.6		1.5~20.6					
Discharge control range (ℓ/min)	5.4~41.0		8.7~61.1		11.6~83.0		13.3~110			
Power supply	Motor pump 3-phase 200/200-220V AC, 50/60Hz (Allowable power fluctuation ±10%)									
External input signal	Photocoupler insulation DC 24V (Max. 27V) 5mA/1ch Minus common									
External output signal	Digital output (2ch) 2 point, Photocoupler insulation, Open corrector output, DC 24V 30mA or less/1ch									
	Point of contact output (1ch) 1 point, (1c contact), Contact capacity DC30V 0.5A, Resistance load, 1c contact									
Usable oil	Mineral oil based special hydraulic fluid/Abrasion resisting hydraulic fluid ·Viscosity grade : ISO VG32~68 ·Viscosity range : 15~400mm ² /s (20~200mm ² /s recommended) ·Contamination : Class NAS9 or lower									
Tank oil temperature	0~60°C (Recommended : 15~40°C)									
Ambient temperature	0~35°C									
Ambient humidity	85% RH or lower									
Installation place	Indoors (Fix with bolts without fail.)									
Weight (kg)	100	115	105	120	135	145	135	145	112	

* Preset to max. discharge. The above max. discharge value is not a guaranteed value, but a theoretical value.
* Other fluid (ex. water, glycol) than mineral oil based hydraulic fluid (hydrate/synthetic) can not be used.
* The weight excludes hydraulic oil.

Nomenclature

SUT	06	D	60	L	21	-	10	-	*	-	***
1	2	3	4	5	6	7	8	9			

1 Basic

SUT : SUT series

2 Tank capacities

00 : Pump & motor type
03 : 30 ℓ
06 : 60 ℓ
10 : 100 ℓ
16 : 160 ℓ

3 Kind of pump

D : Tandem gear pump
S : Single gear pump

4 Maximum pump discharge rate

15 : 15 ℓ/min
30 : 25 ℓ/min
40 : 40 ℓ/min
60 : 60 ℓ/min
80 : 80 ℓ/min
110 : 110 ℓ/min

5 Unit layout

No symbol : Pump & Motor Type
L : tank horizontally equipped type

6 Maximum pressure

07 : 0.7MPa
10 : 10.0MPa
16 : 15.7MPa
21 : 20.6MPa

7 Design No.

Number is progressed by model changes.

8 Function option

No symbol : No DC reactor, no noise filter
F : With dc reactor. With noise filter
C : SUT**S15/SUT**S30/SUT**D80
(P.22○mark) with 16-stage PQ function, communication and remote operation)

9 Non-standard No.

No symbol : Standard

Specification List

Intelligent Coolant Pump



Rotating speed control

Model	ECP02-6-3-10	ECP02-6-6-10	ECP04-6-3-10	ECP04-6-6-10	ECP08-3-3-10	
Number of casing stages	6	6	6	6	3	
Number of impellers	3	6	3	6	3	
Motor capacity (kW)	0.9	1.6	1.5	2.6	2.3	
Discharge (ℓ/min)	20~75		50~170		100~300	
Total head (m)	35~10	70~30	38~10	75~27	42~13	
Rated current (A)	200V/60Hz	3.1	5.2	4.9	8.4	7.3
	220V/60Hz	2.9	4.7	4.5	7.7	6.6
Thermal set value (A)	15	30				
Weight (kg)	33.5	33.5	34.0	35.0	41.0	
Applicable fluid	Water-soluble coolant					
Atmospheric temperature	0 ~ 40 °C					
Ambient humidity	20~85% RH					
Machining tools and devices	Lathe, Machining tool, Special machine, etc.					

Pressure control function

Model	ECP02-6-3-10-P	ECP02-6-6-10-P	ECP04-6-3-10-P	ECP04-6-6-10-P	ECP08-3-3-10-P	
Number of casing stages	6	6	6	6	3	
Number of impellers	3	6	3	6	3	
Motor capacity (kW)	0.9	1.6	1.5	2.6	2.3	
Discharge (ℓ/min)	10~75	10~90	25~170	25~190	50~280	
Total head (m)	35~10	60~10	30~10	70~10	30~10	
Rated current (A)	200V/60Hz	3.1	5.2	4.9	8.4	6.1
	220V/60Hz	2.9	4.7	4.5	7.7	5.5
Thermal set value (A)	15	30				
Weight (kg)	33.5	33.5	34.0	35.0	41.0	
Applicable fluid	Water-soluble coolant					
Atmospheric temperature	0 ~ 40 °C					
Ambient humidity	20~85% RH					
Machining tools and devices	Lathe, Machining tool, Special machine, etc.					

Nomenclature



- | | | |
|---|--|---|
| <p>1 Series name (Basic model)
ECP : Middle- and low-pressure coolant pump</p> <p>2 Max. pump discharge
02 : 2 m³/hour
04 : 4 m³/hour
08 : 8 m³/hour</p> <p>3 Number of casing stages
3 : 3 stages
6 : 6 stages</p> | <p>4 Number of impellers
3 : 3 impellers
6 : 6 impellers</p> <p>5 Design No.
Numbered successively every model change.</p> | <p>6 Position of discharge port (viewed from control unit display)
F : Front
B : Back
L : Left
R : Right</p> <p>7 Pressure control function
P : Pressure controlled
No symbols : Without pressure control (Rotating speed control only)</p> |
|---|--|---|

Note) Model selection is limited as above list.

Intelligent high-pressure coolant pump



Specifications

Model	ECPH20-045	ECPH16-060	ECPH13-070
Pressure (MPa)	4.4	5.9	6.9
Flow rate (ℓ/min)	28	20	14
Power supply	3φ 200/200, 220V 50/60Hz		
Motor rated current (200/200/220V) (A)	11.2/11.0/10.2	11.5/11.1/10.3	11.2/10.9/10.2
External input signal	3 points, Photocoupler insulation, DC24V 5mA/point (DC24V supplied by user), ·START/STOP signal ·LOAD/UNLOAD signal		
External output signal	Warning output	Photocoupler insulation, Open collector output, DC+24V 30mA or less, GND common	
	Pressure switch output	Photocoupler insulation, Open collector output, DC+24V 30mA or less, GND common	
	Alarm output	1c contact output (Dry contact), Contact capacity, Resistance load, Min. load current	
Applicable fluid	Water-soluble coolant (Concentration 2% or more, Contamination shall be NAS1638 Class 12 or lower.)		
Allowable fluid temperature	0~40°C		
Operating environment	0~35°C, 85%RH or less, Indoor, altitude of 1,000m or less		
Painted color	Black		
Protection Class	Controller : IP54, Motor: IP44		
Weight (kg)	65	55	55

Nomenclature



- | | |
|--|--|
| <p>1 Series name (Basic model)
ECPH : Intelligent high-pressure coolant pump (ECPH series)</p> <p>2 Pump displacement
20 : 20 cm³
16 : 16 cm³
13 : 13 cm³</p> <p>3 Max. working pressure
045 : 4.4 MPa
060 : 5.9 MPa
070 : 6.9 MPa</p> | <p>4 Design No.
Numbered successively every model change.</p> <p>5 Option symbol
No symbol : Without noise filter box
F : With noise filter box</p> <p>6 Non-Standard No.
3-figure number for non-standard model.</p> |
|--|--|

Specification List

Oil Cooling Unit (Circulating type)



Rotating speed control

Model	AKZ148	AKZ328	AKZ438	AKZ568	AKZ908	
Oil Cooling Unit equivalent horsepower (HP)	0.5	1.2	1.5	2.0	3.0	
Cooling capacity (50/60Hz) *Note 1 (kW)	1.3/1.4	2.8/3.2	3.8/4.3	5.0/5.6	8.0/9.0	
Compressor (Hermetic DC swing type)	Equivalent to 0.4 kW	Equivalent to 0.75 kW	Equivalent to 1.1 kW	Equivalent to 1.5 kW	Equivalent to 2.2 kW	
Oil pump discharge (ℓ/min)	12/14.4	24/28.8	24/28.8	30/36	30/36	
Power supply	Main circuit (50/60Hz) AC 3-phase 200/200·220V 50/60Hz					
	Operation circuit (50/60Hz) DC12/24V					
	Capacity 200V/50Hz	1.20kVA/3.5A	1.70kVA/5.3A	2.31kVA/6.6A	3.21kVA/9.4A	5.02kVA/15.2A
	200V/60Hz	1.32kVA/3.7A	1.73kVA/5.5A	2.35kVA/6.8A	3.30kVA/9.5A	5.14kVA/15.6A
220V/60Hz	1.33kVA/3.9A	1.75kVA/5.7A	2.45kVA/7.0A	3.34kVA/9.2A	5.20kVA/14.5A	
Dimensions (H×W×D) (mm)	650×360×440	790×360×440	990×360×440	1,110×470×560	1,220×560×680	
Weight (kg)	52	58	67	97	125	
Usable oil	Lubricating oil, Mineral oil based hydraulic fluid (however, not usable for Phosphate ester based hydraulic fluid, Water, Water-soluble liquid, Chemicals, Fuel, Cutting and grinding liquids)					
Wiring circuit breaker rated current (A)	10	10	10	15	20	

Note) *1. Cooling capacity means the value at standard point (inlet oil temperature: 35°C, room temperature: 35°C), oil pump rated discharge, and oil ISO VG32. Capacity tolerances are about ±5%.

Standard, Semi-standard, Non-standard Models

●AKZ8 (Circulating type)

	Standard specifications	Semi-standard items	Non-standard	Remarks
Low-viscosity pump	○			Viscosity of oil: 1.4~200 mm ² /s
Relief pressure : 0.5MPa	○			Pump relief clacking pressure
Timer	○			99-hour timer
Outlet oil temperature sensor	○			
Circuit breaker		B		
CE specifications		C		European Safety Standard
Different voltage specifications (Transformer)		E*	* 1, 2, 3 as shown available	E1:AC220,230V 50/60Hz E2:AC380,400,415V 50/60Hz E3:AC440,460,480V 50/60Hz
Oil heater		H		
Oil tank		T1,T		T1(AKZ148·AKZ328·AKZ438),T(AKZ568,AKZ908)
Low load control specifications		X		Cooling capacity range 0~100% (AKZ148·AKZ328·AKZ438·AKZ568) ("H" specifications excluded)
Serial/Parallel communication extension board			SP	For AKZ148, AKZ328, AKZ438 Standard, -C, -E*, -T

- Machine tuning thermistor (Lead wire length: 5m, 10m)
- Oil temperature control thermistor (Lead wire Length: 5m, 10m)
- Main machine communication extension board (Serial communication and Serial/Parallel communication are possible)

Nomenclature

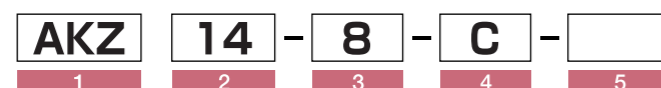

1 Basic (Standard type Oil Cooling Unit)
AKZ : High-accuracy inverter oil cooling unit, Circulating type, for main shaft and lubricating oil

2 Nominal cooling capacity (kW) × 10
Adoption from the sequence of JIS Z8601 (2 digits)
Ex.) 14 means nominal cooling capacity of 1.4 kW.
14, 18, 32, 35, 43, 45, 56, 90, etc.

3 Design No. (Model change No.)
6, 7, 8...

4 Option No. (B, C, E, H, T, X)
Easily selecting optional specifications until previous series as semi-standard from the list. According to this system, delivery of optional spec was shorter.
* For combination, separately contact us.

5 Individual order symbol (4-digit alphanumerical characters)
Non-standard specifications for meeting individually required specifications not included in the semi-standard.
* For special specifications (UL compliance, Tropical treatment specifications, or others), separately contact us.

Oil Cooling Unit (Immersion type)



Rotating speed control

Model	AKZJ188	AKZJ358	AKZJ458	AKZJ568	AKZJ908	
Oil Cooling Unit equivalent horsepower (HP)	0.5	1.2	1.5	2.0	3.0	
Cooling capacity (50/60Hz) *Note 2 (kW)	1.6/1.8	3.2/3.5	4.2/4.5	5.0/5.6	8.0/9.0	
Compressor (Hermetic DC swing type)	Equivalent to 0.4 kW	Equivalent to 0.75 kW	Equivalent to 1.1 kW	Equivalent to 1.5 kW	Equivalent to 2.2 kW	
Power supply	Main circuit (50/60Hz) AC 3-phase 200/200·220V 50/60Hz					
	Operation circuit (50/60Hz) DC12/24V					
	Capacity 200V/50Hz	1.07kVA/3.1A	1.35kVA/5.2A	1.94kVA/5.7A	3.3kVA/9.4A	3.9kVA/11.2A
	200V/60Hz	1.09kVA/3.2A	1.78kVA/5.2A	1.96kVA/5.7A	3.3kVA/9.4A	4.1kVA/11.7A
220V/60Hz	1.07kVA/2.8A	1.79kVA/4.9A	1.98kVA/5.3A	3.4kVA/9.0A	4.3kVA/11.2A	
Dimensions (H×W×D) (mm)	980×360×440	1,120×360×440	1,320×360×440	1,450×470×500	1,630×560×620	
Weight (kg)	38	44	53	83	132	
Usable fluid	Water-soluble cutting and grinding oil, Cutting and grinding oil, Lubricating oil, Oil pressure hydraulic fluid, Industrial water (however, not usable for chemicals, foods, fuel)					
wiring circuit breaker *Note 1 rated current (A)	10	10	10	15	20	

Note) *2. Cooling capacity means the value at standard point (tank liquid temperature: 35°C, room temperature: 35°C) and oil ISO VG32. Capacity tolerances are about ±5%.

Standard, Semi-standard, Non-standard Models

●AKZJ8 (Immersion type)

	Standard specifications	Semi-standard items	Non-standard	Remarks
Low-viscosity pump	○			Viscosity of fluid: 0.5~200 mm ² /s
Timer	○			99-hour timer
Circuit breaker		B		
CE specifications		C		European Safety Standard
Different voltage specifications (Transformer)		E*	* 1, 2, 3 as shown available	E1:AC220,230V 50/60Hz E2:AC380,400,415V 50/60Hz E3:AC440,460,480V 50/60Hz
Oil heater		H		
Specified painted color			○	
Serial/Parallel communication extension board			SP	For AKZJ188, AKZJ358, AKZJ458 Standard, -C, -E*

- Machine tuning thermistor (Lead wire length: 5m, 10m)
- Oil temperature control thermistor (Lead wire Length: 5m, 10m)
- Main machine communication extension board (Serial communication and Serial/Parallel communication are possible)

Nomenclature

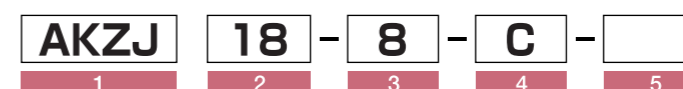

1 Basic (Standard type Oil Cooling Unit)
AKZJ : High-accuracy inverter oil cooling unit, immersion open type, for cutting and grinding liquid (oil)

2 Nominal cooling capacity (kW) × 10
Adoption from the sequence of JIS Z8601 (2 digits)
Ex.) 14 means nominal cooling capacity of 1.4 kW.
14, 18, 32, 35, 43, 45, 56, 90, etc.

3 Design No. (Model change No.)
6, 7, 8...

4 Option No. (B, C, E, H, T)
Easily selecting optional specifications until previous series as semi-standard from the list. According to this system, delivery of optional spec was shorter.
* For combination, separately contact us.

5 Individual order symbol (4-digit alphanumerical characters)
Non-standard specifications for meeting individually required specifications not included in the semi-standard.
* For special specifications (UL compliance, Tropical treatment specifications, or others), separately contact us.

Optional parts

Optional parts for ECORICH

Name	Model	Max. working voltage	Working current	Contact resistance	Protection	When alarm is output		CE specifications	Others
						Temperature	Oil level		
Temperature switch	E-MQT83PD-65X1-10	24V DC/AC	0.05~0.5A	30 mΩ or less	IP65	65°C Abnormal temperature rise: Open DIFF 5~8deg	—	—	Thermostat VDE0631
Level switch	E-LSN-140-L-B		0.05A DC/AC	1Ω or less	IP65	—	EHU14~25 7L or less: Open EHU40R (1/2X3/4 bussing used) 22L or less: Open	—	Not applicable *Note 1

Note) *1. Operating voltage 24V or less, Components : DIN connector, as lead switch is employed

Model applicable

Oil temperature switch

EHU14-L04 (0.75 kW)-EHU25-M07 (2.8 kW) Tank port (T1, T2) & Drain port (DR1, DR2) and EHU40-M07 (3.7 kW) Tank port (T1, T2) & Drain port (DR1).
*Use bushing or other joints to mount.

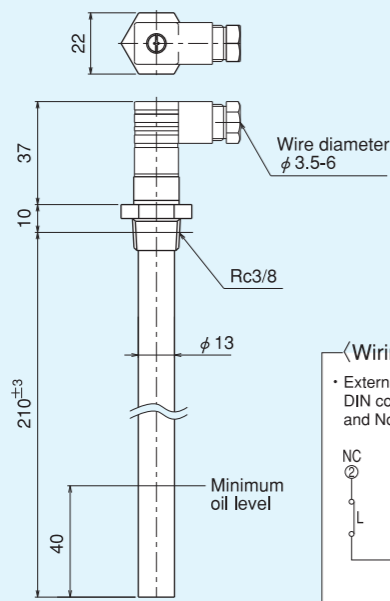

Level switch

EHU14-L04 (0.75 kW)-EHU25-M07 (2.8 kW) Drain port DR2 (Rc1/2) can be directly mounted. (Other ports cannot be equipped with.)
EHU40-M07 (3.7 kW) Drain port DR1 (Rc3/4) can be mounted with bushing (1/2X3/4). (Other port cannot be mounted.)

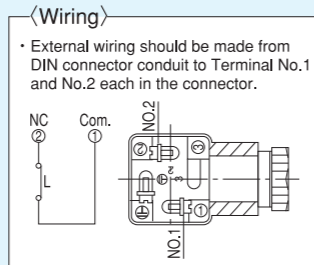
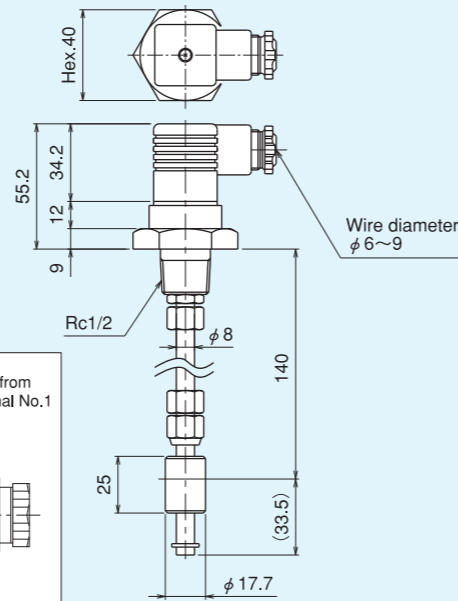

Note) In normal operation, it is considered to be normal. In test run or when oil is not in the tank, the contact is opened(OFF). It is not abnormal.

Optional parts for Intelligent Coolant Pump

Name	Model	Accessories
Relaying box	ECP-OPT001-10	① Relaying box main body (4 types of rubber bushing included) ② Mounting sheet metal (to mount relay box onto pump) ③ Electric wire 750 mm (Black) ④ Signal wiring port cover (For mounting hole (φ16)) ⑤ Fixing screw (M14X10 mm machine screw with washer) ⑥ Handling procedures Manual
Cable clamp for power cable	E**-OPT001-10	① Cable clamp main body ② Gasket ③ Screw
Cable clamp for control signal	E**-OPT002-10	① Cable clamp main body ② Gasket ③ Screw



Optional parts for Oil Cooling Unit -1 (AKZ8 and AKZJ8 series)

Nomenclature and application of thermistor

This optional thermistor installed onto the main machine and its oil piping can sense the temperature to control.

Nomenclature and application of optional machine tuning thermistor and oil temperature control thermistor are shown as below. These are not standard accessories to the Oil Cooling Unit main body. If needed, separately place an order.

Name	Model	Lead wire length L (m)	Form	Application (installed by user)	Models applied
Machine tuning thermistor	AKZ 8-OP-K5	5m		For machine tuning control (Embedded in main machine body)	AKZ 8 series
	AKZ 8-OP-K10	10m			
	AKZ 8-OP-A5	5m		For machine tuning control (Attached onto main machine surface)	AKZJ 8 series
	AKZ 8-OP-A10	10m			
Oil temperature control thermistor	AKZ 8-OP-Y5	5m		For return oil temperature control (Installed to main machine oil piping)	AKZ 8 series
	AKZ 8-OP-Y10	10m			

Thermistor characteristics : Resistance, R25 (25°C resistance) = 20kΩ Tolerance : ±2%

Installation and connection

For AKZ 8-OP-K

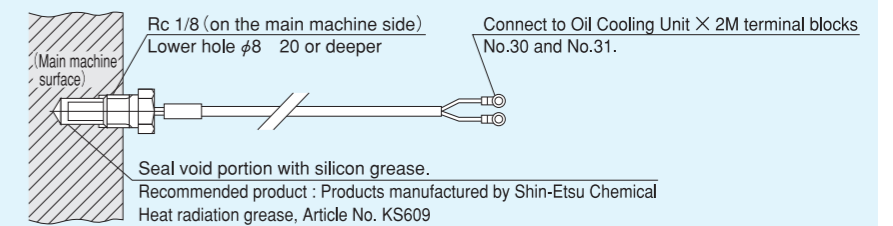

For AKZ 8-OP-A

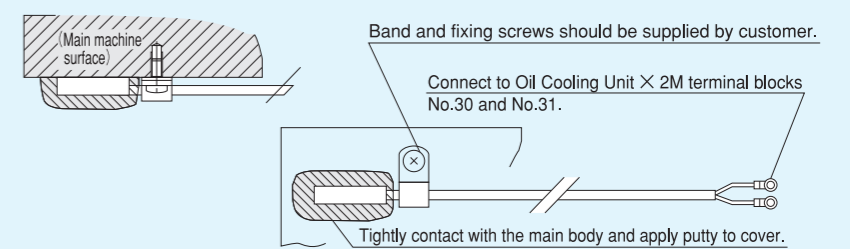

For AKZ 8-OP-Y

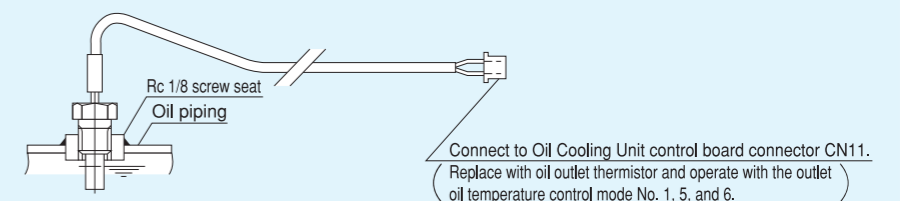

Optional parts

Optional parts for Oil Cooling Unit -2 (AKZ8 and AKZJ8 series)

Main machine communication extension board

Install this optional board to Oil Cooling Unit to connect with the main machine; and

1. Operation mode and setting can be selected on the main machine side, and
2. Oil Cooling Unit alarm code and temperature data (machine surface temperature, room temperature, inlet oil temperature, outlet oil temperature, difference in temperature between inlet and outlet, inverter frequency) can be read on the main machine side.

Communication method	Model	Position	Models applicable	Specifications No.
Serial communication only	AKZ8-OP-CS	On the surface of Oil Cooling Unit control board	AKZ148, AKZ328, AKZ438, AKZJ188, AKZJ358, AKZJ458	SS08303
		Back side of the front sheet metal of Oil Cooling Unit electric component box	AKZ568, AKZ908, AKZJ568, AKZJ908	
Serial or parallel communication	AKZ8-OP-CSP	Back side of the front sheet metal of Oil Cooling Unit electric component box	AKZ568, AKZ908, AKZJ568, AKZJ908	SS08370

- Note) 1. For AKZ148, AKZ328, and AKZ438 (-B and -H each) and AKZJ188, AKZJ358, and AKZJ458 (-B and -H each); AKZ8-OP-CS is not available.
 2. For AKZ148, AKZ328, and AKZ438 (Standard, -C, -E, -T each) and AKZJ188, AKZJ358, and AKZJ458 (Standard, -C, -E each), it is difficult to apply the optional AKZ8-OP-CSP. Please place an order for the non-standard with putting "-SP" at the end of the model number.
 3. For communication procedures and specifications, refer to the separate specifications.

Installation position of AKZ8-OP-CS (serial communication only)

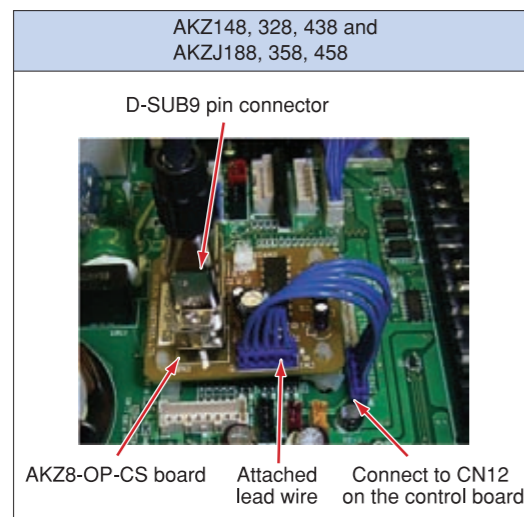

- Dimensions of communication board
- Fix the communication board with four locking supports.

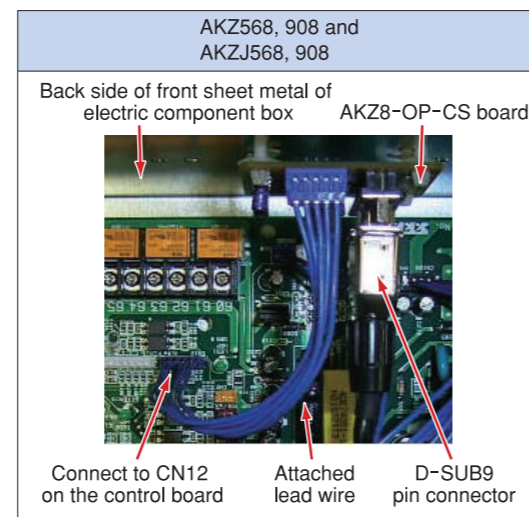

- Connect D-SUB9 pin connector to RS232C support on main machine or personal computer. (No male connectors are included as accessories.)

Installation position of AKZ8-OP-CSP (serial/parallel communication)

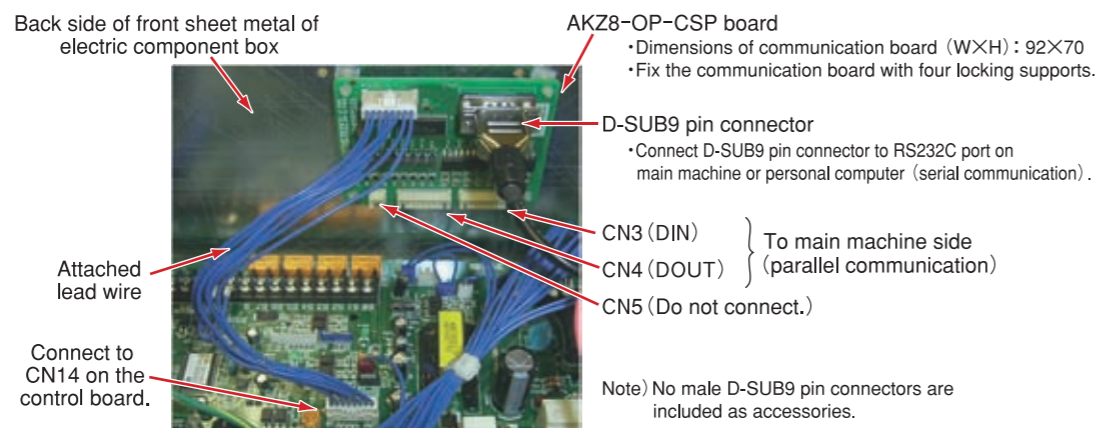

- Dimensions of communication board (W×H): 92×70
- Fix the communication board with four locking supports.

- Connect D-SUB9 pin connector to RS232C port on main machine or personal computer (serial communication).

Note) No male D-SUB9 pin connectors are included as accessories.

Characteristics

ECORICH

Output characteristics (P-Q characteristics)

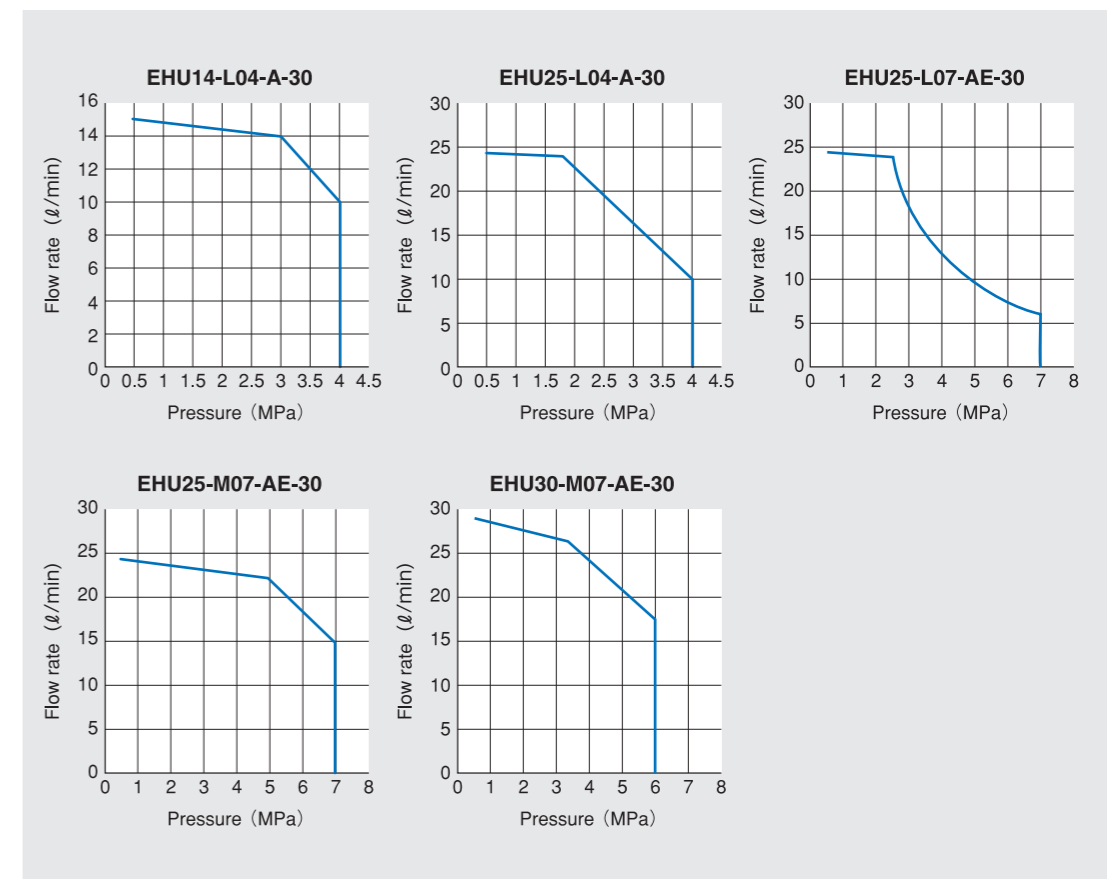

ECORICH-R

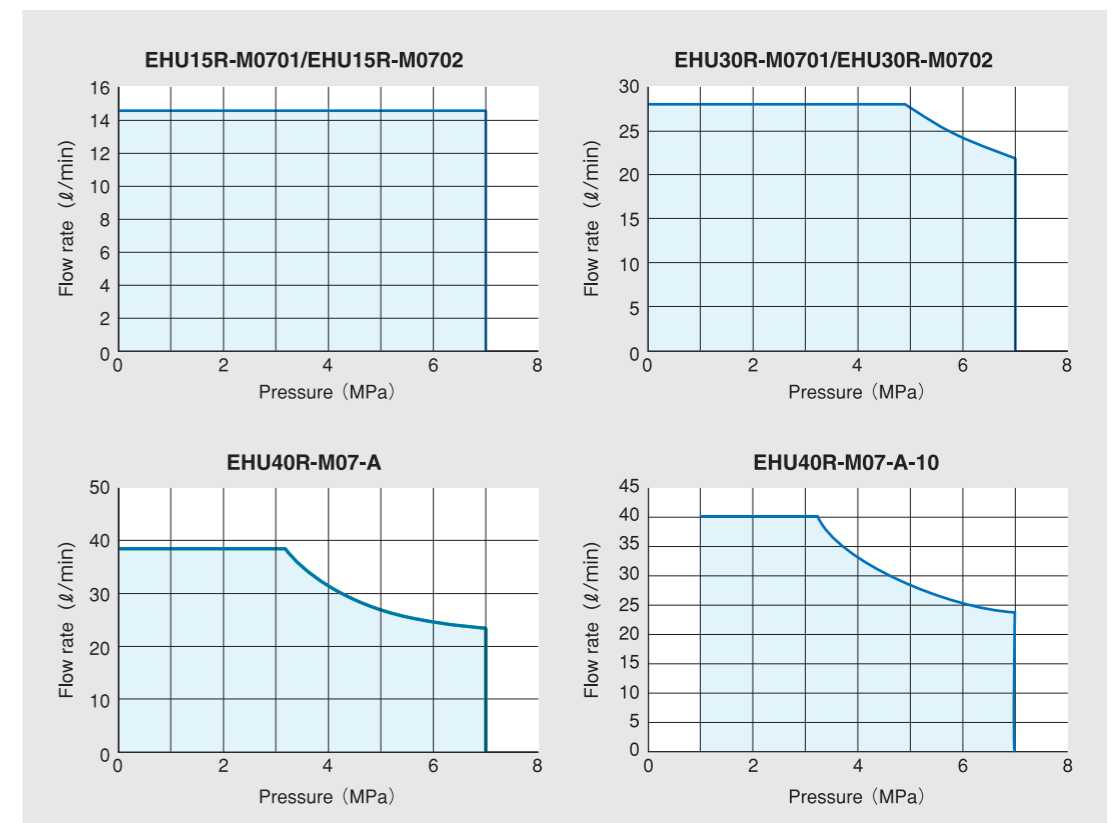

Characteristics

Super Unit

Max. output characteristics (Pressure-Flow rate characteristics)

SUT ** S15 * 07 • SUT ** S30 * 07 • SUT ** S40 * 07
SUT ** S60 * 07 • SUT ** S80 * 07

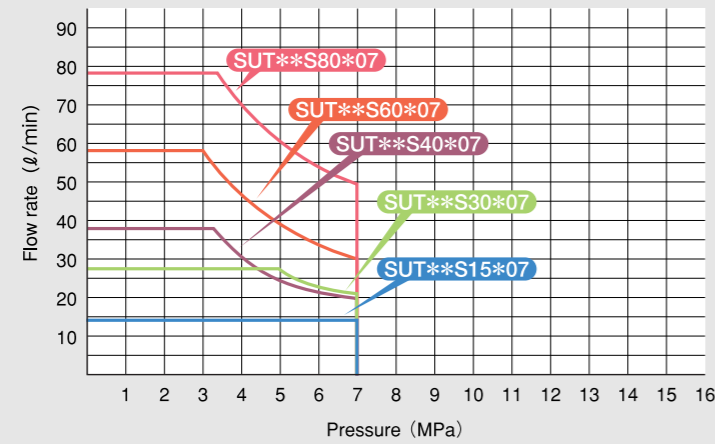

※ At continuous supply of flow, should be less than following flow rate.
 ■ SUT**S15*07 : less than 3 l/min
 SUT**S30*07 : less than 5 l/min
 SUT**S40*07 : less than 8 l/min
 SUT**S60*07 : less than 14 l/min
 SUT**S80*07 : less than 19 l/min

SUT ** S15 * 10 • SUT ** S30 * 10

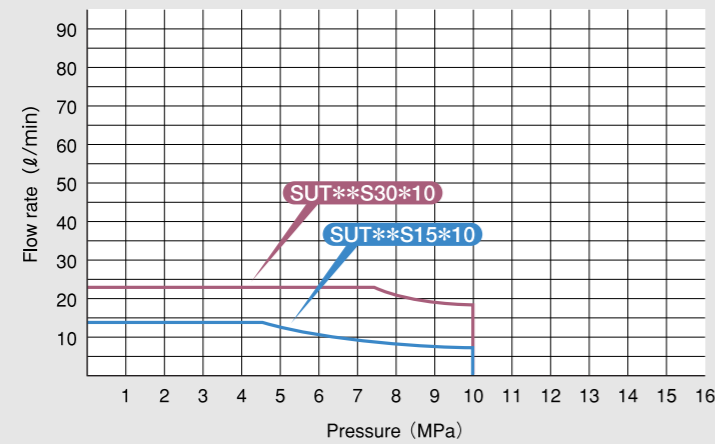

※ At continuous supply of flow, should be less than following flow rate.
 ■ SUT**S15*10 : less than 3 l/min
 SUT**S30*10 : less than 5 l/min

SUT ** S30 * 16 • SUT ** S15 * 16

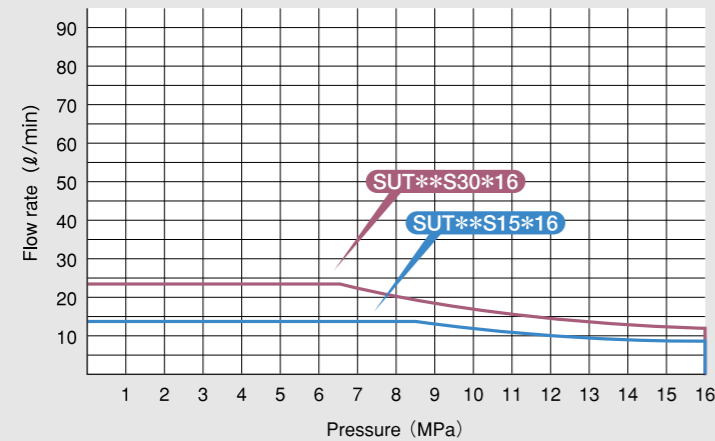

※ At continuous supply of flow, should be less than following flow rate.
 ■ SUT**S15*16 : less than 5 l/min
 SUT**S30*16 : less than 5 l/min

SUT ** D40 * 16

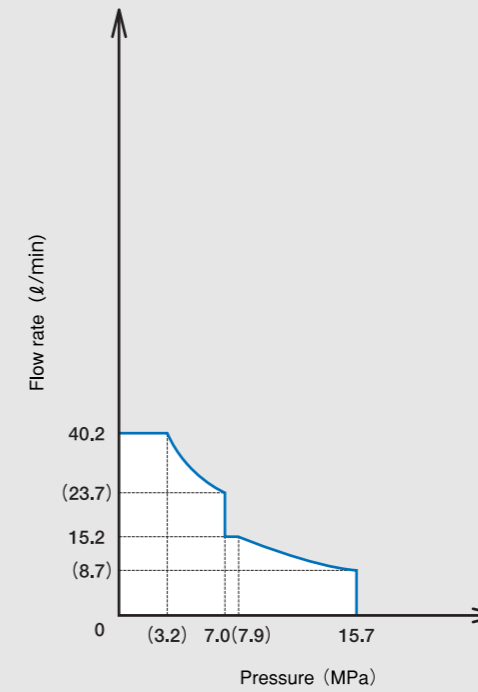

※ At continuous supply of flow, should be less than following flow rate.
 ■ less than 8 l/min, at max pressure

SUT ** D60 * 21

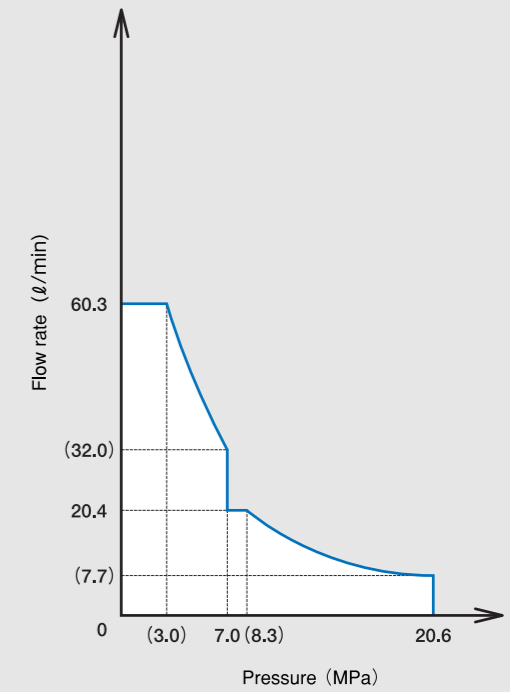

※ At continuous supply of flow, should be less than following flow rate.
 ■ less than 6.5 l/min, at max pressure

SUT ** D80 * 21

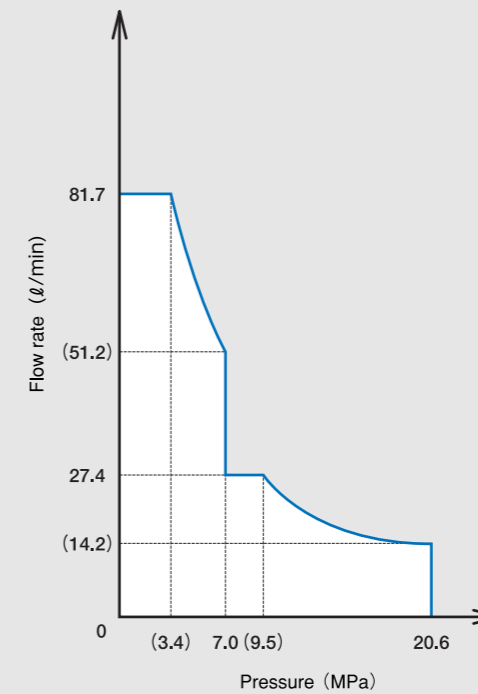

※ At continuous supply of flow, should be less than following flow rate.
 ■ less than 14 l/min, at max pressure

SUT ** D110 * 21

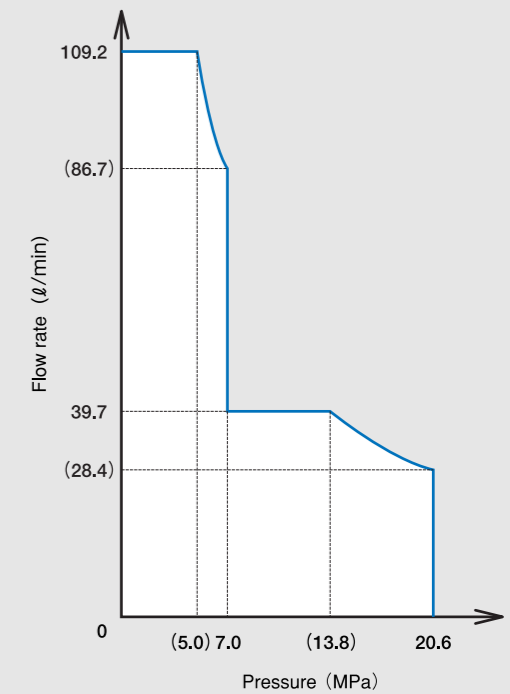

※ At continuous supply of flow, should be less than following flow rate.
 ■ less than 14 l/min, at max pressure

Characteristics

Intelligent Coolant Pump

Rotating speed control

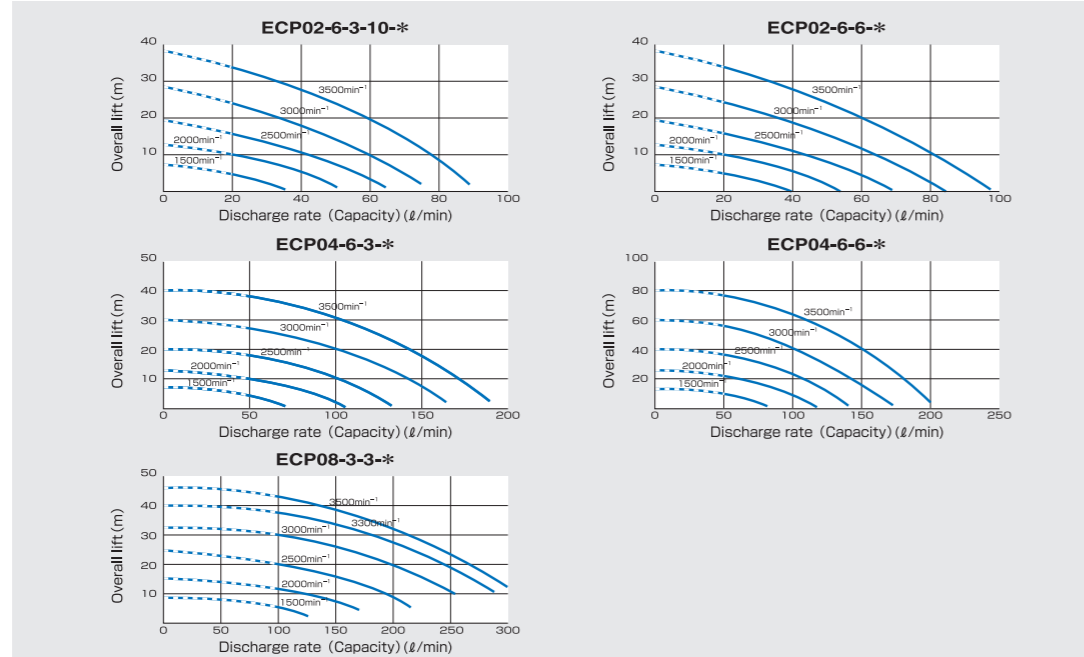

Pressure control

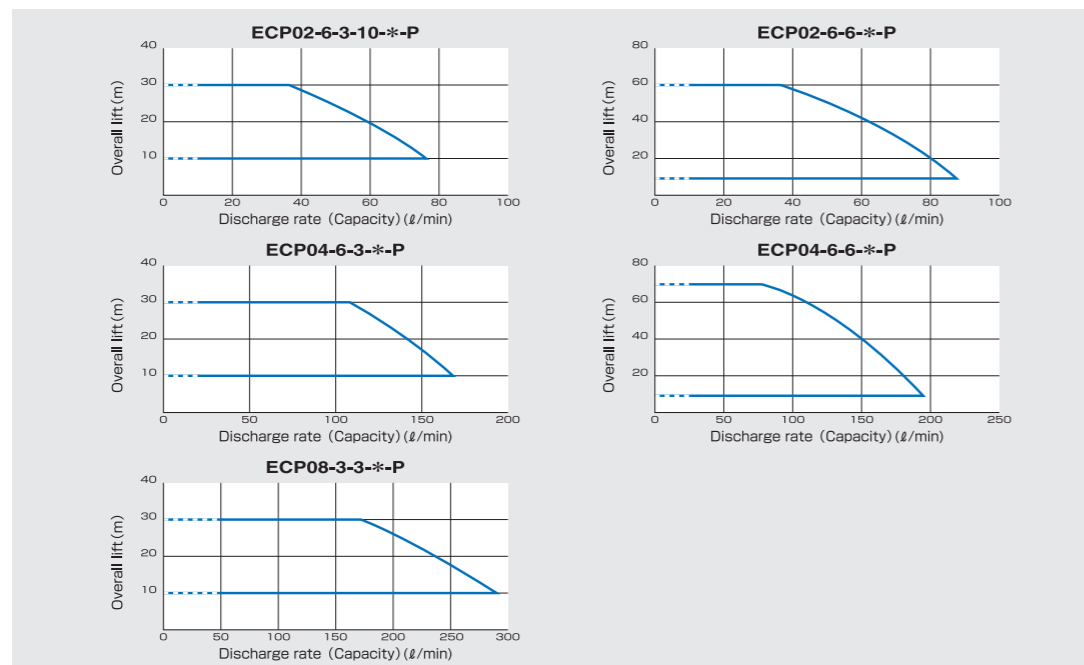

Intelligent High-Pressure Coolant Pump

Output Characteristics

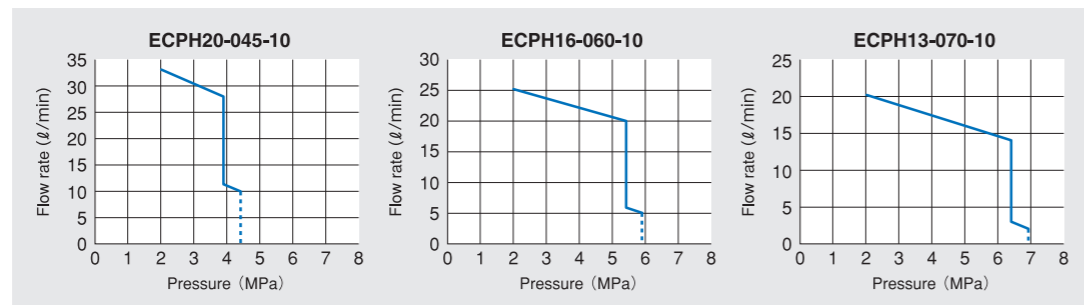

Oil Cooling Unit AKZ8 (Circulating type)

Characteristic curve

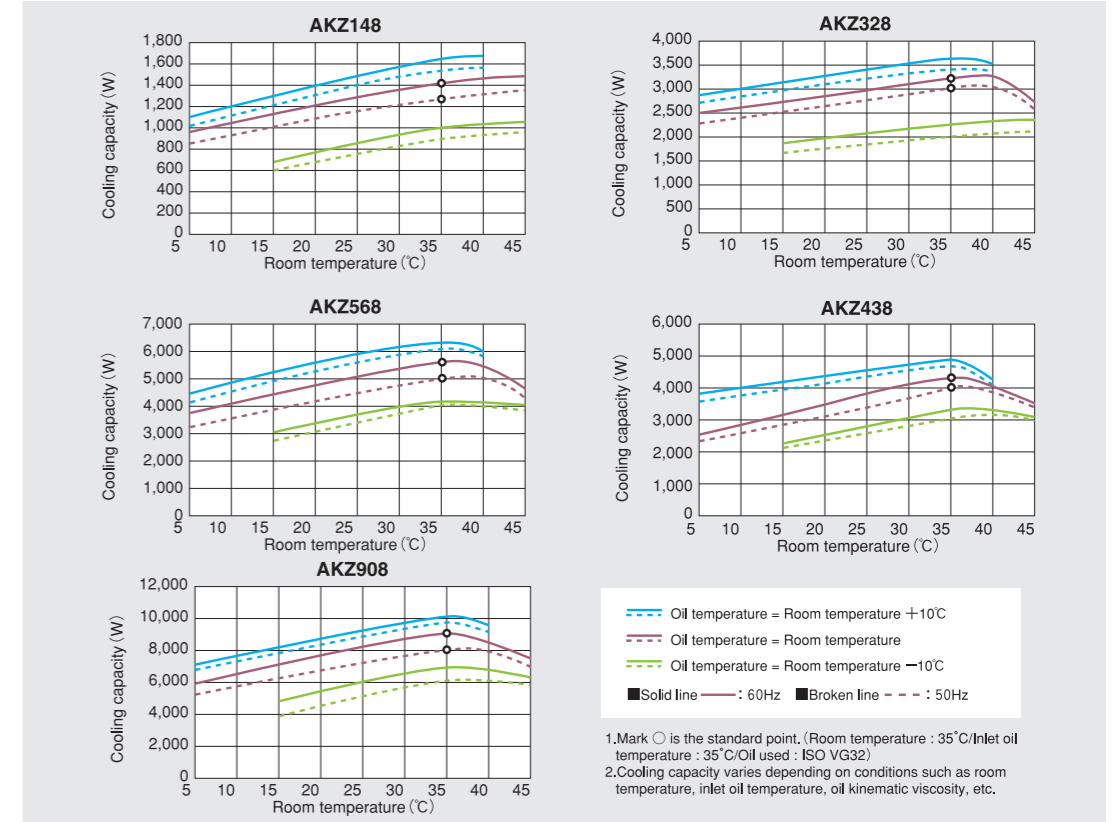

Oil Cooling Unit AKZJ8 (Immersion type)

Characteristic curve

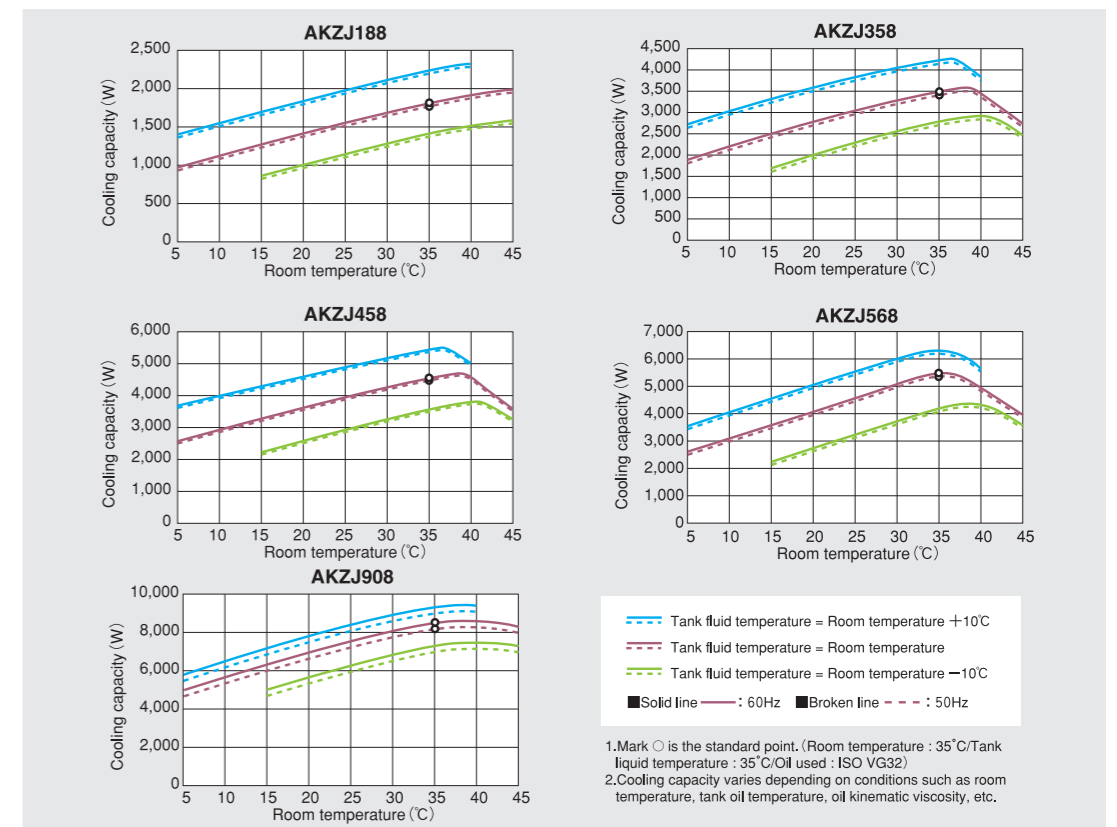



DAIKIN INDUSTRIES, LTD.

Oil Hydraulic Equipment

Osaka Office

DAIKIN Esaka Building, Tarumi-cho 3-21-3,

Suita, Osaka, Japan 564-0062

TEL : 81-6-6378-8764

FAX : 81-6-6378-8738

E-mail Address: hyd_eco@daikin.co.jp

Home Page: <http://www.daikin.com>