

BIBUS



Fluid Technology for Life Science Applications

WWW.LIFESCIENCE.BIBUS.COM



The partner for your success

Are you looking for a reliable fluid technology specialist who can help you meet your requirements to the highest of standards?

BIBUS AG is a family-run trading, service and production company that has been operating for 75 years. Via our worldwide sales organisation and supplier network, we provide tailored solutions to support our customers. These range from individual products right through to the end-to-end production of complete systems.

We understand our customers' requirements and are able to identify the critical tasks within applications. In turn, this enables us to create precisely tailored component and/or system configurations to ensure reliable and

cost-effective operations.

We specialise in the development of high-performance fluid control systems that meet strict technical and regulatory requirements while delivering a sophisticated, industrialised, and production-ready solution.

Supporting your success:
We measure our performance by your success!

Table of contents

THE BIBUS GROUP AT A GLANCE	04
PRODUCT MANAGEMENT	06
SYSTEM SOLUTIONS	10
MEDIA-WETTED	12
MEDIA-SEPARATED	32
SHAPE MEMORY ACTUATORS	43
PROPORTIONAL TECHNOLOGY	47
FILTRATION	64
SENSORS	66
FITTINGS	70
RESISTANCE	72

Milestones

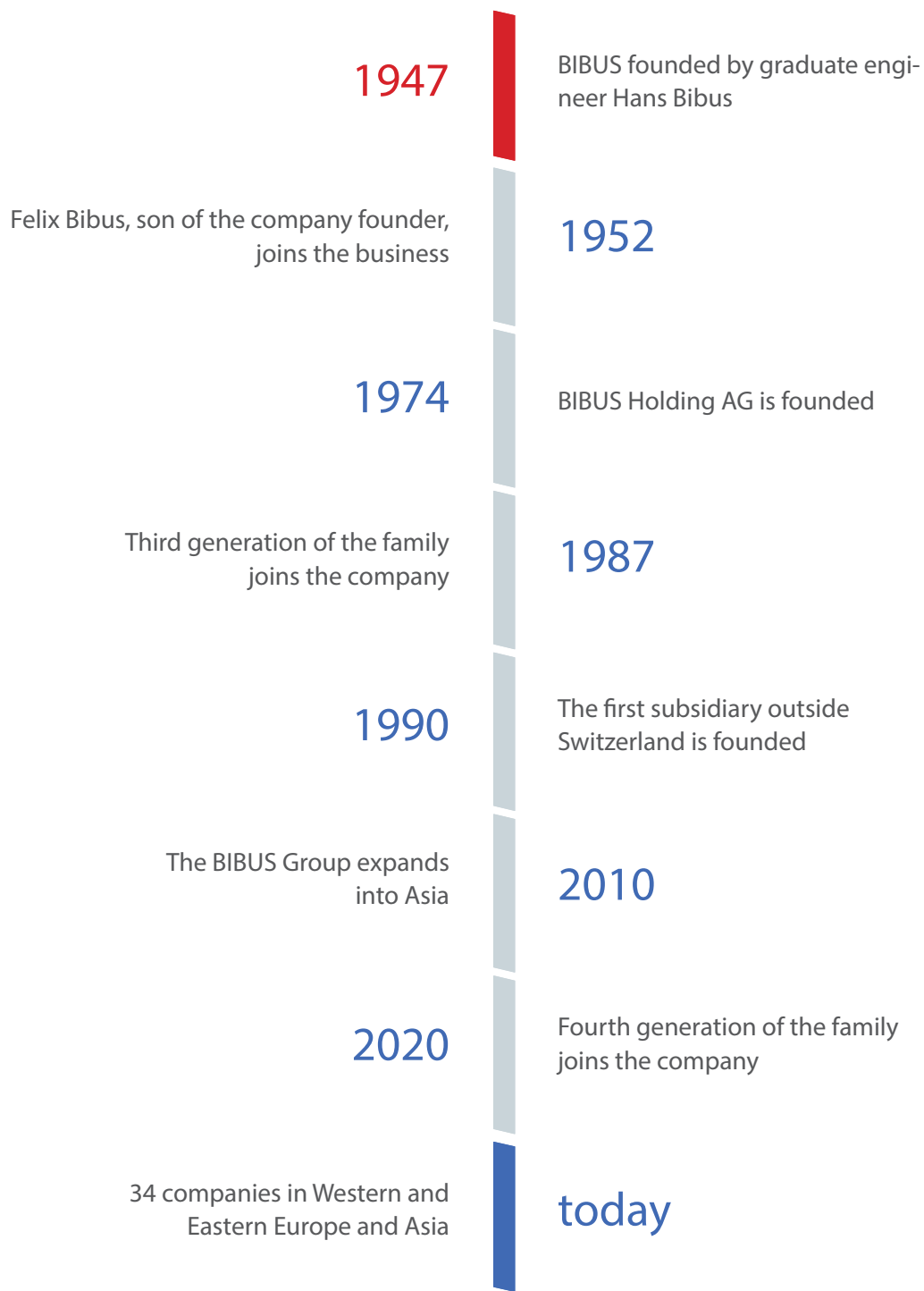

supporting your success

Facts and figures

BIBUS HOLDING AG

Founded

1947 by graduate engineer Hans Bibus

Business divisions

Technology, Materials, Electronics

Core competencies

Engineering, Logistics, Services

Number of employees

More than 1'100

International locations

Local presence in 29 countries

Number of companies

51 subsidiaries

Product management



CUSTOMERS & APPLICATIONS

Are you looking for an expert in fluid control systems – a partner with whom you can discuss your ambitious requirements? Our strengths lie in our ability to understand our customers' needs, identify the critical tasks within applications and propose solutions that offer a high level of added value. To help you succeed, we will not only develop, produce and document our fluid technology solution but will also assist you with your certification process right through to validation.

ENGINEERING & INDUSTRIALISATION

Our business model is based on a consulting approach – whether you are purchasing a standard product or a customised complete solution. We believe that only the best possible configurations of components and systems will do. When developing our solutions, we keep a close eye on the costs to achieve systems that deliver on functionality but are ingeniously simple. That is why our employees possess a wealth of technical knowledge and understand the industry-specific requirements. We will not merely develop a high-performance fluid control system that meets the stringent technical and regulatory requirements but will provide you with a sophisticated, industrialised solution that is production-ready. Harness the power of our expertise to boost your own success.



SUPPLY CHAIN & PRODUCTION

The process of procuring components for the fluid control system plays a major role in the total development time. We factor in the time-to-market target for your project right from the start. And we build the regulatory requirements and quality assurance measures into our products and systems as early as the solution finding and development stage. As a result, we can get ready-tested functional models, prototypes and pilot series to you quickly. Lean production and strong partnerships with our suppliers are the key to cost-efficient procurement. These are the ingredients we combine to create the recipe for your product's success.



PRODUCT LIFE CYCLE & MANAGEMENT

Believe us when we say that there is more to a partnership than simply devising and delivering solutions; we do not stop there, but also facilitate market positioning via commercial agreements in a way that perfectly complements the development of your product. In accordance with our motto, we deliver product management built on expertise to ensure a successful product life cycle.

START YOUR PROJECT WITH US

BIBUS supplies proven and innovative fluid control systems that are precisely adapted to your requirements and processes. This shortens your time to market and reduces system complexity and costs, in order to deliver world-class quality solutions.

We look forward to hearing from you!



System solutions



Modular fluid block system

A modular and compact solution for controlling gaseous and liquid media using proportional, media-separated and media-wetted valve technology. Media, on-off and proportional valves can all be functionally combined on a single block.

APPLICATIONS
Medical technology

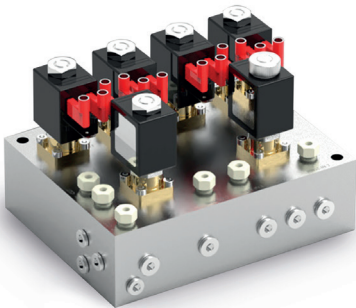

High-pressure relief block

High-quality valve technology with a compact mechanism for switching and dosing the gaseous medium reliably.

APPLICATION
Analytical technology

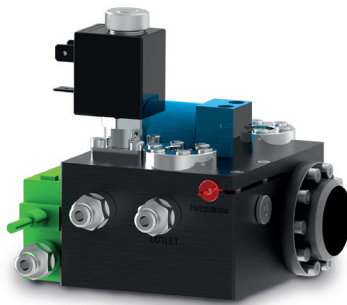

High-pressure gas control system

High-precision pressure and flow measurement technology, coupled with proportional and valve technology, control the gaseous medium precisely to the set pressure and flow.

APPLICATION
Medical technology

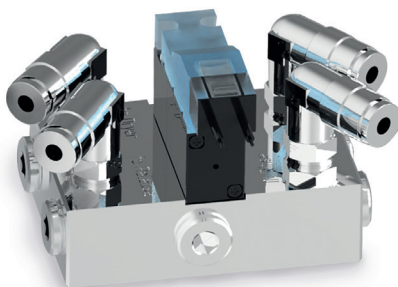

Micro valve block

Micro valve with 10 mm size for high pneumatic pressures and highest tightness.

APPLICATION
Analytical technology

System solutions

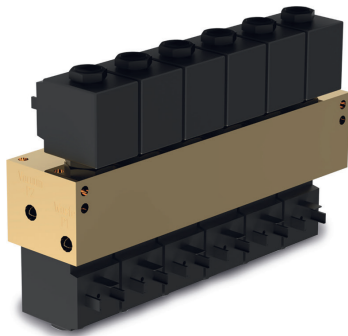

High-pressure manifold

Valve block with integrated high-performance switching valves for supplying gas to reactors.

APPLICATION
Analytical technology



Dosing unit

Compact pump block for pumping and dosing of aggressive, liquid media.

APPLICATION
Analytical technology

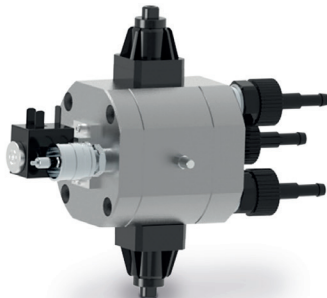

Gas control unit

Sophisticated design without any blind holes. Combined with ultra-compact valve technology for controlling the pressure and flow rate of gaseous media.

APPLICATION
Medical technology

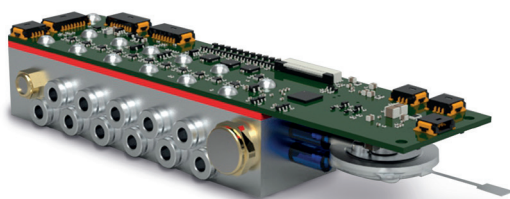

Miniaturised valve block

Compact, low-noise and energy-efficient valve, pump and measuring technology, combined in the smallest installation space.

APPLICATION
Medical technology

8 mm cartridge valve

Directly controlled solenoid valve, electrically operated, cartridge design

K8 – K8X SERIES

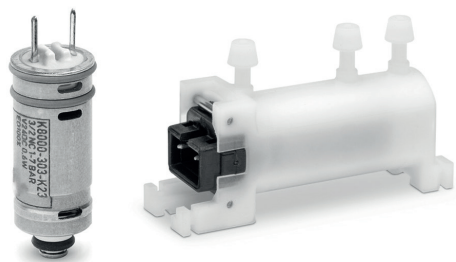

APPLICATION

The special design makes this product suitable for technical solutions that call for compact dimensions and high performance. The valve has been designed to prioritise two aspects when controlling media: low power consumption and minimal noise emissions.

FEATURES

- Compact design
- Minimal noise emissions
- Low electrical power consumption
- Long service life
- Oxygen-compatible

SPECIFICATIONS

TECHNICAL SPECIFICATIONS	K8 – K8X SERIES
Function	2/2-way, 3/2-way, NC, NO – 3/2-way, universal
Type	Directly controlled poppet valve
Pneumatic connection	Cartridge design or hose nozzle connection
Nominal diameter	0.5 ... 0.7 mm
Kv value	0.08 ... 0.15
Operating pressure	-1 ... 7 bar
Operating temperature	0 ... 50°C
Medium	Filtered compressed air, inert gases, oxygen
Shifting time (ISO 12238)	ON < 10 ms – OFF < 10 ms
Mounting position	Any
MATERIALS IN CONTACT WITH MEDIA	
Body	Brass – stainless steel – thermoplastic PBT
Seals	FKM
Inner parts	Stainless steel – enamelled copper
ELECTRICAL SPECIFICATIONS	
Voltage	3 ... 24 V DC – other voltages available on request
Voltage fluctuation range	±10%
Power consumption	0.6 W
Duty cycle	100% duty cycle
Electrical connection	2 pins 0.5 x 0.5 mm, spacing of 4 mm – JST connector, 300 mm wires
Degree of protection	IP00
SPECIAL SOLUTIONS AVAILABLE ON REQUEST	
	To order the oxygen version, please add OX1 at the end of the standard model designation.

8 mm cartridge booster valve

Pilot-operated solenoid valve, with internal electropneumatic pilot control, cartridge design

K8B SERIES



APPLICATION

The pilot-operated solenoid valves from the K8B series are enhanced versions of the 8 mm solenoid valves from the K8 series and they feature a higher flow rate. The special design makes them suitable for technical solutions that call for compact dimensions and a high flow rate.

FEATURES

- Compact design
- High flow rate
- Long service life
- Minimal noise emissions
- Low electrical power consumption
- Oxygen-compatible

SPECIFICATIONS

TECHNICAL SPECIFICATIONS	K8B SERIES
Function	2/2-way, 3/2-way, NC, NO
Type	Pilot-operated poppet valve
Pneumatic connection	Cartridge design – M7 connections – on base plate
Nominal diameter	3.6 mm
Kv value (l/min)	2.8
Operating pressure	1 ... 7 bar
Operating temperature	0 ... 50°C
Medium	Filtered compressed air, inert gases, oxygen
Shifting time (ISO 12238)	ON < 15 ms – OFF < 15 ms
Mounting position	Any
MATERIALS IN CONTACT WITH MEDIA	
Body	Brass – stainless steel – PBT – aluminium
Seals	FKM
Inner parts	Stainless steel – enamelled copper
ELECTRICAL SPECIFICATIONS	
Voltage	3 ... 24 V DC – other voltages available on request
Voltage fluctuation range	±10%
Power consumption	0.6 W
Duty cycle	100% duty cycle
Electrical connection	2 pins 0.5 x 0.5 mm, spacing of 4 mm – JST connector, 300 mm wires
Degree of protection	IP00
SPECIAL SOLUTIONS AVAILABLE ON REQUEST	
	To order the oxygen version, please add OX1 at the end of the standard model designation.

8 mm fast-switching valve

3/2 – 2/2-way fast-switching valve with flapper mechanism, directly controlled

320 SERIES MICRO VALVE



APPLICATION

This product sets new trends in terms of its small dimensions, low weight, reduced energy requirements and minimal noise emissions while also offering an incredibly long service life. This valve can be used in the fields of medical technology, rehabilitation technology and analytics whenever these features are required.

FEATURES

- Switching cycles > 500 million
- Frictionless
- Shifting times < 1.5 ms
- Extremely low weight of 9 g
- Maximum frequency: 300 Hz
- Extremely low noise generation

SPECIFICATIONS

TECHNICAL SPECIFICATIONS	320 SERIES
Function	2/2-way, 3/2-way valve, NC, NO
Type	Flapper valve, fast-switching valve
Pneumatic connection	Base plate screwed connection Ø 3.5 mm
Nominal diameter	Approx. 0.8 mm
Flow rate	30 l/min at an air pressure of 6 bar
Operating pressure	0 ... 8 bar or vacuum
Operating temperature	-10 ... 50°C
Medium	Filtered compressed air, vacuum
Shifting time (ISO 12238)	ON < 1.5 ms – OFF < 1.5 ms
Mounting position	Any
MATERIALS IN CONTACT WITH MEDIA	
Body	Plastic
Seals	HNBR, FKM
Inner parts	Stainless steel
ELECTRICAL SPECIFICATIONS	
Voltage	6 V DC, 12 V DC, 24 V DC
Voltage fluctuation range	±10%
Power consumption	1.4 ... 2.4 W
Duty cycle	100% duty cycle
Electrical connection	Valve cable AWG 28 / IP52 with Molex Pico-SPOX and rubber cap
Insulation class	IP52
SPECIAL SOLUTIONS AVAILABLE ON REQUEST	

10 mm micro valve

Directly controlled solenoid valve, electrically operated, flanged version

KL-KLE SERIES



3/2 way
Up to a nominal diameter of 1.3 mm

2/2 way
Up to a nominal diameter of 1.6 mm

APPLICATION

The miniaturised solenoid valves from the KL and KLE series have been developed for industrial applications and medical devices that call for high flow rates and pressures in conjunction with compact dimensions.

FEATURES

- Compact design
- High flow rate
- Enhanced KLE version for high operating pressures
- M8 electrical connection with M8 3-pin plug
- Monostable and bistable manual override
- With detenting/non-detenting manual override or without manual override

SPECIFICATIONS

TECHNICAL SPECIFICATIONS	KL-KLE SERIES
Function	2/2-way NC – 3/2-way, NC, NO – 3/2-way, universal
Type	Directly controlled solenoid valve
Pneumatic connection	Flanged version or base plate
Nominal diameter	0.6 ... 1.6 mm
Kv value (l/min)	0.12 ... 0.50
Operating pressure	0 ... 9 bar
Operating temperature	0 ... 50°C
Medium	Filtered compressed air, inert gases, oxygen
Shifting time (ISO 12238)	ON < 10 ms – OFF < 10 ms
Mounting position	Any
MATERIALS IN CONTACT WITH MEDIA	
Body	Thermoplastic PBT
Seals	FKM
Inner parts	Stainless steel – brass
ELECTRICAL SPECIFICATIONS	
Voltage	6 ... 24 V DC – other voltages available on request
Voltage fluctuation range	±10%
Power consumption	1 W – 1.3/0.3 W – 4/1 W
Duty cycle	100% duty cycle
Electrical connection	Connector Mod. 121-8 ... - M8 connector Mod. CS ...
Degree of protection	IP50 with connector 121-8 ... - IP65 with M8 connector
SPECIAL SOLUTIONS AVAILABLE ON REQUEST	

10 mm micro valve

Directly controlled solenoid valve, electrically operated, flanged version

KN SERIES

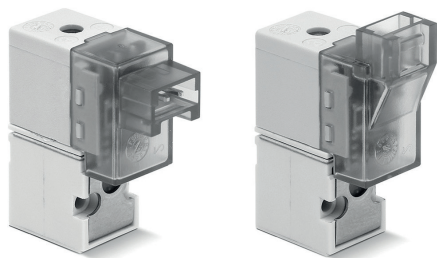

APPLICATION

Thanks to its low energy consumption and compact design, the small direct-acting poppet valve from the KN series is suitable for applications with a high volume flow rate.

FEATURES

- Low energy consumption
- Compact design
- High flow rate
- Mounting interface surface acc. to ISO 15218
- Oxygen-compatible

SPECIFICATIONS

TECHNICAL SPECIFICATIONS	KN SERIES
Function	3/2-way, NC, NO, universal
Type	Directly controlled solenoid valve
Pneumatic connection	Flanged version or base plate
Nominal diameter	0.65 ... 1.1 mm
Kv value (l/min)	0.15 ... 0.39
Operating pressure	0 ... 3 ... 7 bar
Operating temperature	0 ... 50°C
Medium	Filtered compressed air, inert gases, oxygen
Shifting time (ISO 12238)	ON < 10 ms – OFF < 10 ms
Manual override	Monostable
Mounting position	Any
MATERIALS IN CONTACT WITH MEDIA	
Body	PBT
Seals	NBR – FKM
Inner parts	Stainless steel
ELECTRICAL SPECIFICATIONS	
Voltage	5 ... 24 V DC – other voltages available on request
Voltage fluctuation range	±10%
Power consumption	1.3/0.25 ... 4/1 W (starting/holding)
Duty cycle	100% duty cycle
Electrical connection	Connector Mod. 121-8...
Degree of protection	IP50
SPECIAL SOLUTIONS AVAILABLE ON REQUEST	
	To order the oxygen version, please add OX2 at the end of the standard model designation.

10 mm micro valve

Directly controlled solenoid valve, electrically operated, flanged version

3QE SERIES

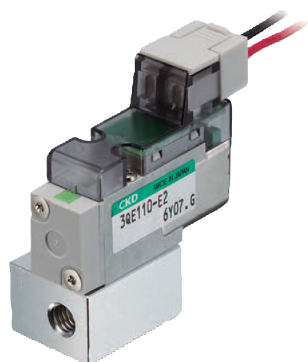

APPLICATION

The exceptional quality and energy efficiency of the 3QE micro valves are what sets them apart from other valves. Thanks to their unique features, they are widely used in the fields of medical technology and analytics.

FEATURES

- Service life: 200 million switching cycles
- Power consumption of just 0.35 to 0.1 W
- Minimal self-heating of max. 5°C
- Vacuum-compatible
- Oxygen-compatible
- Lightweight design: 12.5 g
- Short shifting times: 6 ms/3 ms (ON/OFF)

SPECIFICATIONS

TECHNICAL SPECIFICATIONS	3QE 10 MM SERIES
Function	2/2-way, 3/2-way, NC, NO
Type	Directly controlled directional valve
Pneumatic connection	Flanged version or M5
Nominal diameter	Approx. 0.6 mm
Flow rate	25 l/min / 18 l/min at an air pressure of 6 bar
Operating pressure	-1 ... 7 bar
Operating temperature	Ambient -5 ... 55°C / Fluid 5 ... 55°C
Medium	Filtered compressed air, inert gases and oxygen
Shifting time	ON < 6 ms – OFF < 3 ms
Mounting position	Any
MATERIALS IN CONTACT WITH MEDIA	
Body	Resin
Seals	HNBR or FKM
Inner parts	Stainless steel, resin
ELECTRICAL SPECIFICATIONS	
Voltage	3, 5, 12, 24 V DC / 100 V AC
Voltage fluctuation range	±10%
Power consumption	0.35 W/0.1 W/0.93 W with AC
Duty cycle	100% duty cycle
Electrical connection	Connectors, wires of various lengths
Insulation class	B
SPECIAL SOLUTIONS AVAILABLE ON REQUEST	
	Oxygen versions, custom-made versions, oil and grease-free, integrated filtration, protective circuit, ozone-resistant version

10 mm micro valve

Directly controlled solenoid valve, electrically operated, flanged version

3QB SERIES

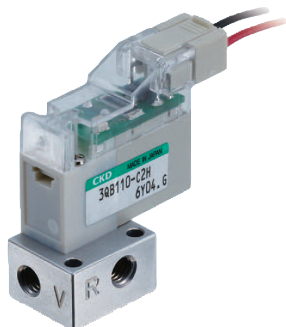

APPLICATION

The ingenious valve design supports high flow rates. Thanks to the modular concept, the valve can be adapted for all kinds of customer requirements. The valve's versatility makes it suitable for a large number of medical technology and analytical applications.

FEATURES

- Exact switching thresholds
- Short response times: < 5 ms or less
- Power consumption: 2.2 / 0.6 W
- Operating pressure: up to 12 bar
- Service life: 200 million switching cycles
- Oxygen-compatible

SPECIFICATIONS

TECHNICAL SPECIFICATIONS		3QB 10 MM SERIES
Function		2/2-way, 3/2-way, NC
Type		Directly controlled directional valve
Pneumatic connection		Flanged version or M5
Flow rate		45 l/min at an air pressure of 6 bar
Operating pressure		-1 ... 6 bar
Operating temperature		-5 ... 50°C
Medium		Filtered compressed air, inert gases, oxygen
Shifting time (ISO 12238)		ON < 5 ms – OFF < 5 ms
Mounting position		Any
MATERIALS IN CONTACT WITH MEDIA		
Body		Resin
Seals		FKM/NBR
Inner parts		Stainless steel
ELECTRICAL SPECIFICATIONS		
Voltage		12, 24 V DC
Voltage fluctuation range		±10%
Power consumption		0.6 W (2.2 W for the first 20 ms)
Duty cycle		100% duty cycle
Electrical connection		Connector
Insulation class		Class 130 (B)
SPECIAL SOLUTIONS AVAILABLE ON REQUEST		Oxygen versions, custom-made versions, oil and grease-free

11 mm micro valve

Direct acting 3/2-way directional valve, electrically operated, flanged version

3QR SERIES



APPLICATION

The large flow valve attains a flow rate of up to 170 l/min at 6 bar operating pressure. The response times of 4 ±1 ms ON and 1.5 ±1 ms OFF are quick, precise, and constant over the service life of the valve. This high-performance valve is suitable for situations where such specifications are required in conjunction with an extremely compact size.

FEATURES

- Service life: 100 million switching cycles
- Power consumption: 2 W / 2.4 W
- Universal design
- Short shifting times: 4 ms/1.5 ms (ON/OFF)
- Vacuum-compatible

SPECIFICATIONS

TECHNICAL SPECIFICATIONS	3QR SERIES
Function	3/2-way, universal
Type	Directly controlled directional valve
Pneumatic connection	Flanged version, M5
Nominal diameter	Approx. 3 mm
Kv value	170 l/min / 150 l/min at an air pressure of 6 bar
Operating pressure	-1 ... 7 bar
Operating temperature	Ambient -5 ... 50°C / Fluid 5 ... 50°C
Medium	Filtered compressed air, vacuum
Shifting time (ISO 12238)	ON < 4 ms – OFF < 1.5 ms
Mounting position	Any
MATERIALS IN CONTACT WITH MEDIA	
Body	Resin, aluminium
Seals	FKM, NBR
Inner parts	NBR, stainless steel
ELECTRICAL SPECIFICATIONS	
Voltage	12, 24 V DC
Voltage fluctuation range	±10%
Power consumption	2.0 W (3.2 W for the first 20 ms)
Duty cycle	5 min duty cycle, minimum of 50 ms for latching
Electrical connection	Connectors, wires of various lengths
Insulation class	B
SPECIAL SOLUTIONS AVAILABLE ON REQUEST	
	Custom-made versions, integrated pressure monitoring, integrated filtration, ozone-resistant version, fast-switching version

10 mm and 13 mm diaphragm valve

Internally piloted diaphragm valve, electrically operated, flanged version with push-in connection

SP SERIES



APPLICATION

This valve is suitable for extremely compact applications with maximum flow rate requirements. Available in widths of just 10 or 13 mm.

FEATURES

- High media temperature
- Diaphragm actuator for flow rates of up to 250 NI/min
- Power consumption of just 0.6 W
- Valve made of PPS and HNBR
- Function: 2/2 NC

SPECIFICATIONS

TECHNICAL SPECIFICATIONS	SP10/SP13 SERIES
Medium	Compressed air
Operating pressure differential	0.2 ... 2 bar
Max. operating pressure	2 bar
Permissible peak pressure	7 bar
Fluid temperature	0 ... 70°C
Ambient temperature	0 ... 60°C
Valve structure	Pilot-operated diaphragm actuator
Internal leakage in cm ³ /min	2 or less
Internal leakage in cm ³ /min	2 or less
Mounting position	Any
Size of push-in fitting connection	Ø 6 (SP10)
Weight	
ELECTRICAL SPECIFICATIONS	
Rated voltage	12 V DC, 24 V DC
Voltage fluctuation range	±10%
Energy consumption	0.6 W
Rated value	50% duty cycle
Thermal class	130 (B)
SPECIAL SOLUTIONS AVAILABLE ON REQUEST	

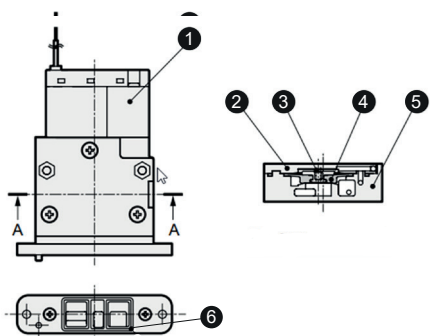

NO.	DESIGNATION	MATERIAL	
1	Coil	-	-
2	Socket	PPS	Polyphenylene sulphide
3	Spring	SUS	Stainless steel
4	Diaphragm	HNBR/PPS	Hydrogenated nitrile-butadiene rubber/polyphenylene sulphide
5	Housing	PPS	Polyphenylene sulphide
6	Seal	HNBR	Hydrogenated nitrile-butadiene rubber

15 mm mini valve

Directly controlled solenoid valve, electrically operated, flanged version

PL SERIES

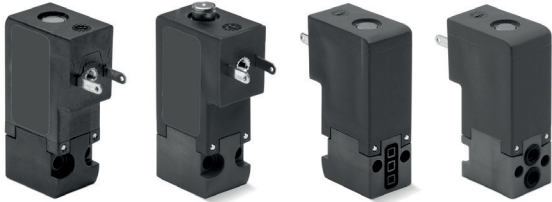

APPLICATION

The PL series can be configured in a large number of ways, making it suitable for use in the fields of industrial automation, life sciences and transportation.

FEATURES

- High pressure range
- Low temperature of down to -50°C
- Voltage range of up to 110 V DC
- Degree of protection: IP65

SPECIFICATIONS

TECHNICAL SPECIFICATIONS	PL SERIES
Function	2/2-way NO – 3/2-way NC – 3/2-way NO – 3/2-way, universal
Type	Directly controlled poppet valve
Pneumatic connection	Flanged version or base plate
Nominal diameter	0.8 ... 1.6 mm
Kv value (l/min)	0.30 ... 0.62
Operating pressure	0 ... 3.5 ... 10 bar
Operating temperature	0 ... 50°C
Medium	0 ... 50°C (FKM) / -50°C ÷ 50°C (NBR available for low-temperature applications on request)
Shifting time (ISO 12238)	ON < 10 ms – OFF < 15 ms
Manual override	Monostable/bistable (3/2-way PBT versions only)
Mounting position	Any
MATERIALS IN CONTACT WITH MEDIA	
Body	Brass, thermoplastic PBT, PPS
Seals	FKM, NBR, EPDM (on request)
Inner parts	Brass, stainless steel
ELECTRICAL SPECIFICATIONS	
Voltage	6 ... 110 V DC – other voltages available on request
Voltage fluctuation range	±10%
Power consumption	1.2 ... 3 W
Duty cycle	100% duty cycle
Electrical connection	DIN 43650 connector (9.4 mm)
Degree of protection	IP65 with connector
SPECIAL SOLUTIONS AVAILABLE ON REQUEST	

15 mm mini valve

Directly controlled solenoid valve, electrically operated, flanged version, threaded connection and cartridge

PD SERIES

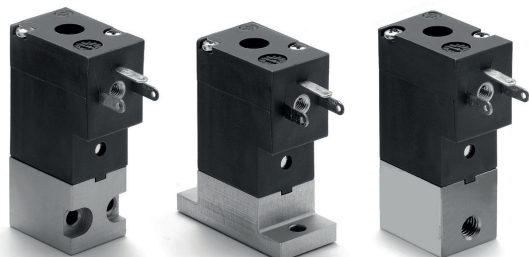

APPLICATION

The directly controlled normally closed 2/2-way poppet valves from the PD series are suitable for use with a wide variety of media, such as inert gases, oxygen and liquids. Thanks to the flange, cartridge and threaded versions, they can be integrated into a large number of fluid systems.

FEATURES

- For liquid and gaseous media
- Very high pressure range
- Oxygen-compatible
- Large nominal diameters for high flow rates
- Choice of various valve body materials
- Vacuum-compatible

SPECIFICATIONS

TECHNICAL SPECIFICATIONS	PD SERIES
Function	2/2-way NO – 3/2-way NC – 3/2-way NO – 3/2-way, universal
Type	Directly controlled poppet valve
Pneumatic connection	Flanged version, threaded connection and cartridge
Nominal diameter	0.8 ... 2.5 mm
Kv value (l/min)	0.39 ... 1.93
Operating pressure	-0.9 ... 4 ... 12 bar
Operating temperature	0 ... 50°C
Ambient temperature	0 ... 50°C
Medium	Filtered air of class 5.4.4 according to ISO 8573-1 (max. oil viscosity of 32 cSt), inert gases, liquids (latter on request)
Shifting time (ISO 12238)	< 15 ms
Manual override	Monostable/bistable (3/2-way PBT versions only)
Mounting position	Any
MATERIALS IN CONTACT WITH MEDIA	
Body	Brass, anodised aluminium, POM
Seals	NBR, FKM, EPDM
Inner parts	Stainless steel
ELECTRICAL SPECIFICATIONS	
Voltage	12 V DC to 24 V DC – other voltages available on request
Voltage fluctuation range	1 and 2 W: ±10% – 4 W: ±5%
Power consumption	1 ... 4 W
Duty cycle	100% duty cycle (1 and 2 W) – 50% duty cycle (4 W); see duty cycle diagram
Electrical connection	DIN 43650 connector (9.4 mm)
Degree of protection	IP65 with connector
SPECIAL SOLUTIONS AVAILABLE ON REQUEST	
	To order the oxygen version, please add OX1 or OX2 at the end of the standard model designation.

Directional valve

Directly controlled poppet valve, electrically operated, flanged version, threaded connection, in-line assembly

A SERIES

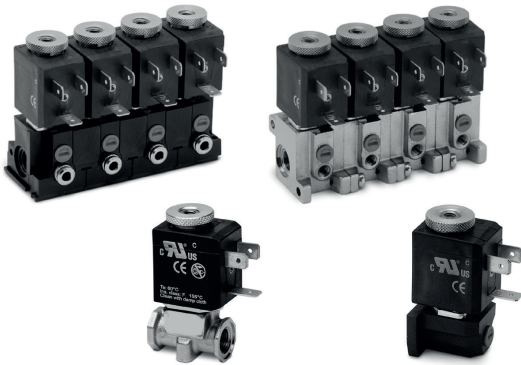

APPLICATION

The directly controlled poppet valves from the A series are available in 2/2-way and 3/2-way NC, NO versions. They can be connected and combined in many different ways, making them suitable for a multitude of applications.

FEATURES

- Connections: M5, G1/8", R1/8", Ø 4 mm plug-in connection
- Version with pulse solenoid coil (bistable)
- 3 different coil sizes
- 11 different voltages
- Inner parts made of stainless steel
- In-line assembly
- Version with integrated quick venting

SPECIFICATIONS

TECHNICAL SPECIFICATIONS	A SERIES
Function	2/2-way, 3/2-way, NC, NO
Type	Directly controlled poppet valve
Pneumatic connection	M5, G1/8", R1/8" – Ø 4 mm plug-in connection – ISO 15218 (CNOMO) and Ø 6 mm hose nozzle flange
Nominal diameter	1.2 ... 2.5 mm
Kv value (l/min)	0.62 ... 2.0
Operating pressure	-0.9 ... 15 bar
Operating temperature	0 ... 60°C (dry air -20°C)
Medium	Filtered air, inert gases
Shifting time	ON < 15 ms – OFF < 25 ms
Manual override	Non-detenting or detenting
Mounting position	Any
MATERIALS IN CONTACT WITH MEDIA	
Body	Nickel-plated brass – burnished brass – PA6 – PBT
Seals	HNBR, FKM
Inner parts	Stainless steel
ELECTRICAL SPECIFICATIONS	
Voltage	12 ... 110 V DC – 24 ... 380 V AC 50/60 Hz
Voltage fluctuation range	±10% (DC) / -15% ÷ +10% (AC)
Power consumption	3 ... 5 W (DC) / 3.5 ... 7 VA (AC)
Duty cycle	100% duty cycle
Protection class	F (155°C)
Electrical connection	DIN EN 175301-803 A – DIN EN 175301-803 B
Degree of protection	IP65 with connector
SPECIAL SOLUTIONS AVAILABLE ON REQUEST	

Media valve

Directly controlled poppet valve, electrically operated, threaded connection

CFB STAINLESS STEEL SERIES

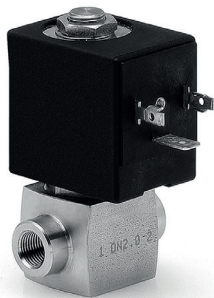

APPLICATION

The directly controlled electromagnetic valves from the CFB stainless steel series are available in 2/2-way, 3/2-way NC versions. They are the ideal solution for a wide range of applications where the environment and media can sometimes be aggressive and contain contamination. Special solutions available on request.

FEATURES

- Stainless steel version for controlling aggressive media
- Maximum reliability, including in demanding application areas
- Very high pressure range
- Wide temperature range

SPECIFICATIONS

TECHNICAL SPECIFICATIONS		CFB SERIES
Function		2/2-way, 3/2-way, NC
Type		Directly controlled poppet valve
Pneumatic connection		G1/8" ... G1/2"
Nominal diameter		1.5 ... 4 mm
Kv value (l/min)		1.33 ... 4.66
Operating pressure		0 ... 4 ... 25 bar
Operating temperature		-10°C ... 140°C
Medium		Liquid and gaseous media with a max. viscosity of 37 cSt
Shifting time		ON < 15 ms – OFF < 25 ms
Manual override		Monostable/bistable (3/2-way PBT versions only)
Mounting position		Any
MATERIALS IN CONTACT WITH MEDIA		
Body		Stainless steel 1.4404
Seals		FKM (EPDM on request)
Inner parts		Stainless steel
ELECTRICAL SPECIFICATIONS		
Voltage		12 V DC, 24 V DC – 24 V AC 50 Hz, 110 V AC 50/60 Hz, 220/230 V AC 50/60 Hz
Voltage fluctuation range		±5% (DC) – ±10% (AC)
Power consumption		19 W (DC) – 15 VA (AC)
Duty cycle		100% duty cycle
Protection class		H (180°C)
Electrical connection		DIN EN 175301-803 A
Degree of protection		IP65 with connector
SPECIAL SOLUTIONS AVAILABLE ON REQUEST		

Cartridge valve

Pneumatically piloted poppet valve

8 SERIES



APPLICATION

The pilot-operated valves from the 8 series are ideal for applications that call for a compact design and a high flow rate. Pneumatic pilot operation can be achieved using a cartridge valve from the 8 series, for example.

FEATURES

- Can be supplied in a version with a PPS body
- High flow rate
- Compact design
- Suitable for integration into fluid systems
- Oxygen-compatible

SPECIFICATIONS

TECHNICAL SPECIFICATIONS		8 SERIES
Function		2/2-way, 3/2-way NC
Type		Pilot-operated poppet
Pneumatic connection		Cartridge design
Nominal diameter		5 ... 6.6 ... 9 mm
Flow rate		420 ... 1480 NI/min (at an air pressure of 6 bar, ΔP 1 bar)
Kv value (l/min)		65 ... 23
Operating pressure		3 ... 6 bar (0 ... 6 bar with external pilot control)
Pilot pressure		3 ... 6 bar
Operating temperature		0 ... 50°C
Medium		Filtered air, inert gases
Mounting position		Any
MATERIALS IN CONTACT WITH MEDIA		
Body		PPS – brass
Seals		FKM
Inner parts		Aluminium
SPECIAL SOLUTIONS AVAILABLE ON REQUEST		To order the oxygen version, please add OX2 at the end of the standard model designation.

Cartridge valve

Pneumatically piloted poppet valve

TC SERIES



APPLICATION

The cartridge design and compact dimensions allow this valve to be integrated directly into a fluid system. The valve body is made of PPS and the seals of FKM, enabling a wide variety of gaseous media to be used.

FEATURES

- Compact design
- High performance
- Easy to mount
- Materials compatible with many different type of gaseous media
- Oxygen-compatible

SPECIFICATIONS

TECHNICAL SPECIFICATIONS	TC SERIES
Function	2/2-way, NC
Type	Compact, moulded diaphragm
Pneumatic connection	G1/8" cartridge or 1/8" NPTF with aluminium block
Flow rate	240 NI/min (at an air pressure of 6 bar, ΔP 1 bar)
Operating pressure	0 ... 10 bar (0 ... 6 bar with external pilot control)
Pilot pressure	0.6 ... 10 bar
Operating temperature	-5 ... 50°C
Medium	Filtered air, inert/medical gases and oxygen
Mounting position	Any
MATERIALS IN CONTACT WITH MEDIA	
Body	PPS / anodised aluminium
Seals	FKM
Inner parts	Stainless steel, PA
SPECIAL SOLUTIONS AVAILABLE ON REQUEST	To order the oxygen version, please add OX2 at the end of the standard model designation.

Diaphragm valve

Internally piloted diaphragm valve, electropneumatically operated, push-in connection

EXA SERIES

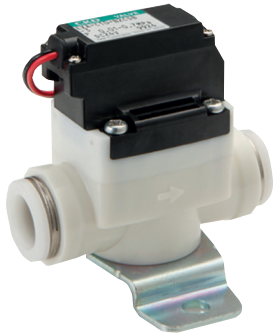

APPLICATION

The distinguishing feature of this internally piloted diaphragm valve is that it offers a high flow rate in conjunction with compact dimensions and low power consumption. In turn, this makes it suitable for use in fluid systems where space is at a premium.

FEATURES

- Wide flow rate range
- High flow rates can be controlled with the piloted diaphragm actuator
- Push-in connection sizes of Ø 6, Ø 8, Ø 10, Ø 12
- Low power consumption
- Oil and grease-free version available
- Compact and lightweight

SPECIFICATIONS

TECHNICAL SPECIFICATIONS		EXA SERIES			
Medium	Compressed air and inert gases				
Operating pressure differential	0.01 ... 7 bar				
Fluid temperature	0 ... 55°C				
Ambient temperature	-5 ... 55°C				
Valve structure	Pilot-operated diaphragm actuator				
Flow rate	470 ... 1058 NI/min (at an air pressure of 6 bar, ΔP 1 bar)				
Mounting position	Any				
Push-in fitting connection size	Ø 6	Ø 8	Ø 10	Ø 12	
Weight	56	57	68	69	
ELECTRICAL SPECIFICATIONS					
Rated voltage	100 V AC (50/60 Hz), 24 V DC, 12 V DC				
Energy consumption	0.6				
Thermal class	Class 130 (B)				
Degree of safety	Lead wire: IPX0, with DIN terminal box: IPX5				

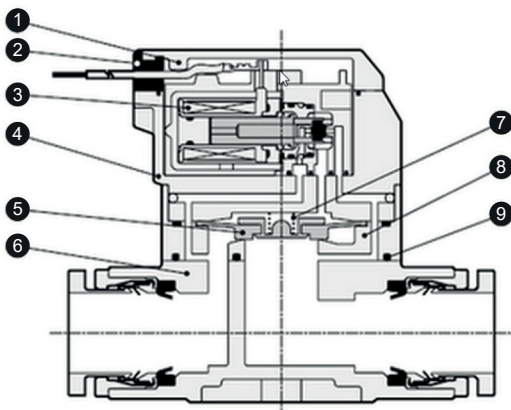

NO.	DESIGNATION	MATERIAL	
1	Cover	PBT	Polybutylene terephthalate
2	Socket	NBR	Nitrile-butadiene rubber
3	Coil	-	-
4	Housing	PPS	Polyphenylene sulphide
5	Diaphragm	HNBR/PPS	Hydrogenated nitrile-butadiene rubber/polyphenylene sulphide
6	Main housing	PBT	Polybutylene terephthalate
7	Spring	SUS	Stainless steel
8	Valve housing	PBT	Polybutylene terephthalate
9	Seal	HNBR	Hydrogenated nitrile-butadiene rubber

10 mm, 19 mm, 21 mm slide valve

Internally piloted slide valve,
electropneumatically operated; push-in, threaded and flange connection

3GA & 4GA SERIES

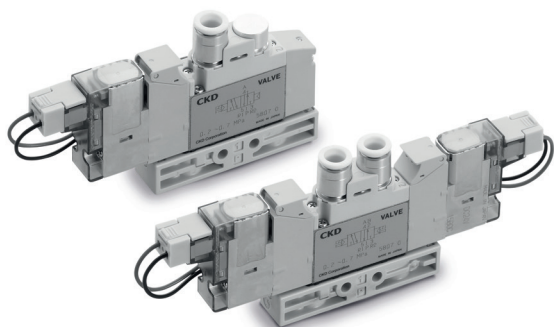

APPLICATION

This exceptional valve is more than a match for the toughest of pneumatic applications in the semi-conductor industry, the fields of medical technology and laboratory automation, and the chemical and pharmaceutical sectors.

FEATURES

- Service life > 100 million switching cycles
- Minimal self-heating
- Very low power consumption
- Internal air filtration
- Extremely low noise emissions
- 420 NI/min to 1500 NI/min

SPECIFICATIONS

TECHNICAL SPECIFICATIONS		3GA1/2/3 & 4GA 1/2/3 SERIES					
Function		3/2 NC, NO 5/2 and 5/3					
Medium		Compressed air and inert gases					
Operating pressure differential		2 ... 7 bar					
Media temperature °C		0 ... 55					
Ambient temperature °C		-5 ... 55					
ELECTRICAL SPECIFICATIONS							
Rated voltage		24 V DC	12 V DC	5 V DC	3 V DC	100 V AC	200 V AC
Energy consumption	Standard	0.35 W		0.35 W		-	
	Low power version	0.1 W		-		-	

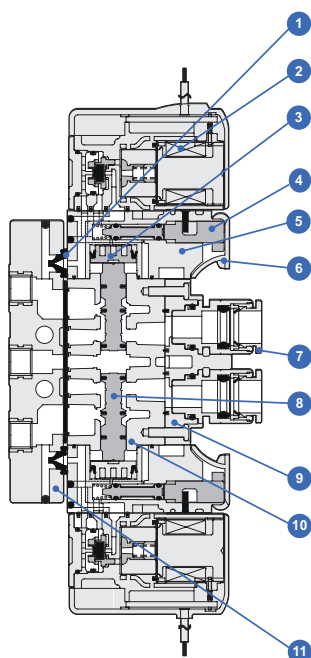

NO.	NAME	MATERIAL
1	Non-return valve	Hydrogenated NBR or FKM
2	Solenoid coil	Hydrogenated NBR or FKM
3	Piston	-
4	Emergency manual override	Plastic
5	Piston chamber	Plastic
6	Protective cover	Plastic
7	Push-in fitting	-
8	Slider	-
9	Fitting adapter	Plastic
10	Housing	Diecast aluminium
11	Pipeline adapter	Plastic

Solenoid valve

Direct acting solenoid valve

UMB1/UMG1 SERIES



APPLICATION

Valve for controlling water and gases.

FEATURES

- Compact and lightweight
- Small interior volume of 80 μ l
- Low electrical power consumption
- Long service life
- For tube connection

SPECIFICATIONS

TECHNICAL SPECIFICATIONS	UMB1/UMG1 SERIES
Function	2/2-way, 3/2-way, NC, NO – 3/2-way, universal
Type	Directly controlled poppet valve
Pneumatic connection	Hose nozzle connection
Nominal diameter	0.9 mm
Kv value	0.14 l/min
Operating pressure	0 ... 2 bar
Operating temperature	5 ... 55°C
Medium	Water, ultra-pure water
Shifting time	8 ms or less
Mounting position	Vertical, solenoid coil pointing down
MATERIALS IN CONTACT WITH MEDIA	
Body	Stainless steel 1.4301 (SUS 304)
Seals	FKM
Inner parts	Stainless steel 1.4301 (SUS 304), PBT
ELECTRICAL SPECIFICATIONS	
Voltage	12 / 24 V DC
Voltage fluctuation range	\pm 10%
Power consumption	1.5 W
Duty cycle	100% duty cycle
Electrical connection	300 mm wires
Insulation class	Class 130 (B)
SPECIAL SOLUTIONS AVAILABLE ON REQUEST	

Slide valve

Directly controlled solenoid valve, electrically operated, flanged and threaded versions

3PA/3PB SERIES

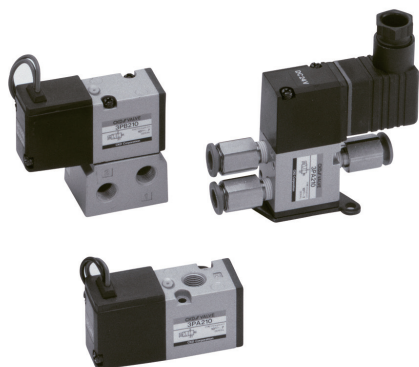

APPLICATION

This compact solenoid valve is suitable for supplying gas and air in medical and analytical devices. It can be used whenever high flow rates are required in conjunction with compact dimensions.

FEATURES

- Low power consumption
- High flow rate
- Extremely compact

SPECIFICATIONS

TECHNICAL SPECIFICATIONS	3PA/3PB SERIES
Function	2/2-way, 3/2-way, NC, NO, universal
Type	Directly controlled directional valve
Pneumatic connection	Flanged version, M5, Rc1/8", Rc1/4", 4" / 6" / 8" push-in fitting
Nominal diameter	Approx. 3 ... 5 mm
Flow rate	140 l/min ... 400 l/min at an air pressure of 6 bar
Operating pressure	-1 ... 7 bar
Operating temperature	Ambient -5°C ... 55°C / Fluid 5°C ... 55°C
Medium	Filtered compressed air, inert gases, vacuum
Shifting time (ISO 12238)	ON < 20 ms – OFF < 20 ms
Mounting position	Any
MATERIALS IN CONTACT WITH MEDIA	
Body	Aluminium, resin
Seals	NBR
Inner parts	Stainless steel
ELECTRICAL SPECIFICATIONS	
Voltage	12 V DC / 24 V DC / 100 ... 220 V AC
Voltage fluctuation range	±10%
Power consumption	1.4 ... 2.4 W
Duty cycle	100% duty cycle
Electrical connection	Connectors and wire ends
Insulation class	B
SPECIAL SOLUTIONS AVAILABLE ON REQUEST	

Solenoid valve

Direct acting solenoid valve with high sealing force and high vacuum resistance

HVB SERIES



APPLICATION

Solenoid valve for controlling process gas under high vacuum.

FEATURES

- Compact dimensions
- High corrosion resistance
- Large number of connection options
- Long service life

SPECIFICATIONS

TECHNICAL SPECIFICATIONS	HVB SERIES
Function	NC solenoid valve for high vacuum
Type	Directly controlled solenoid valve
Pneumatic connection	1/4", 1/8", 3/8", (JXR, NPT, RC, plug nipple)
Nominal diameter	1 mm, 2 mm, 3 mm, 4.5 mm, 6 mm
Kv value	0.04 ... 1.05
Operating pressure	-1 ... 1 bar (test pressure 50 bar)
Operating temperature	0 ... 55°C
Medium	No explosive or corrosive atmospheres
Shifting time (ISO 12238)	ON < 20 ms – OFF < 20 ms
Mounting position	Any
MATERIALS IN CONTACT WITH MEDIA	
Body	Stainless steel 1.4309 or 1.4301
Seals	FKM
Inner parts	Stainless steel, FKM
ELECTRICAL SPECIFICATIONS	
Voltage	12 V DC, 24 V DC / 100/200 V AC
Voltage fluctuation range	±10%
Power consumption	4 ... 11.8 W
Duty cycle	100% duty cycle
Electrical connection	300 mm wires
Insulation class	130 (B)
SPECIAL SOLUTIONS AVAILABLE ON REQUEST	

8 mm diaphragm isolated valve

Direct acting solenoid valve with isolation diaphragm

K8DV SERIES



APPLICATION

Valve for controlling aggressive gases and liquids. Ideal for medical apparatus and analytical instruments.

FEATURES

- Compact and lightweight
- High flow rate
- Very low dead space volume

SPECIFICATIONS

TECHNICAL SPECIFICATIONS		K8DV SERIES
Function		2/2-way, NC
Type		Directly controlled directional valve, media-separated
Pneumatic connection		Cartridge design on base plate
Nominal diameter		0.7 mm
Kv value		0.1
Operating pressure		0 ... 2.1 bar
Operating temperature		5 ... 50°C
Medium		Aggressive liquids/gases and inert gases
Shifting time		ON < 10 ms – OFF < 15 ms
Mounting position		Any
MATERIALS IN CONTACT WITH MEDIA		
Body		PEEK
Seals		FKM – EPDM – FFKM
Inner parts		Stainless steel
ELECTRICAL SPECIFICATIONS		
Voltage		3 ... 24 V DC
Voltage fluctuation range		± 10%
Power consumption		0.6 W
Duty cycle		100% duty cycle
Electrical connection		2 pins 0.5 x 0.5 mm / spacing of 4 mm
Protection class		IP00
SPECIAL SOLUTIONS AVAILABLE ON REQUEST		

Rocker valve

Media-separated solenoid valve with rocker mechanism

KDV 10 mm SERIES



APPLICATION

Valve for controlling aggressive gases and liquids. Ideal for medical apparatus and analytical instruments.

FEATURES

- Compact with flange connection
- Low power consumption
- Various nominal diameters
- Very low dead space volume

SPECIFICATIONS

TECHNICAL SPECIFICATIONS		KDV 10 MM SERIES
Function		3/2 way
Type		Rocker valve
Nominal diameter		0.8 mm, 1.0 mm, 1.3 mm
Air flow rate at max. input pressure		8 l/min / 10 l/min
Operating pressure		-0.5 ... 2 bar
Operating temperature		0 ... 50°C
Medium		Inert gases, oxygen, water
Shifting time (ISO 12238)		ON < 15 ms – OFF < 15 ms
Mounting position		Any
MATERIALS IN CONTACT WITH MEDIA		
Body		PEEK
Seals		FKM, EPDM, FFKM
Inner parts		Stainless steel (no contact with media)
ELECTRICAL SPECIFICATIONS		
Voltage		6 V, 12 V, 24 V DC
Voltage fluctuation range		±10%
Power consumption		1 ... 4 W
Duty cycle		100% duty cycle
Electrical connection		DIN 43650 connector (9.4 mm), DIN EN 175301-803 C (8 mm), 300 mm wires
Protection class		IP40
SPECIAL SOLUTIONS AVAILABLE ON REQUEST		

Diaphragm isolated valve

Direct acting solenoid valve with isolation diaphragm

PDV SERIES

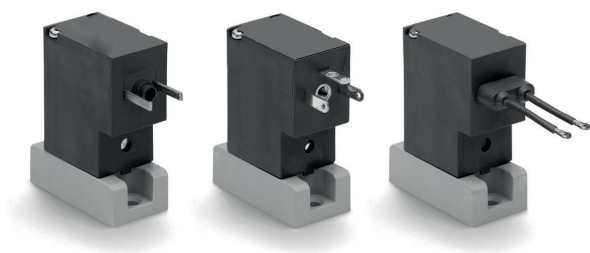

APPLICATION

Valve for controlling aggressive gases and liquids.

FEATURES

- Compact with flange connection
- Low power consumption
- Various nominal diameters
- High shifting pressures
- Ideal for medical apparatus and analytical instruments

SPECIFICATIONS

TECHNICAL SPECIFICATIONS		PDV SERIES
Function		2/2-way, NC
Type		Directly controlled, isolation diaphragm
Pneumatic connection		Base plate
Nominal diameter		0.8 ... 2 mm
Kv value (l/min)		0.25 ... 0.8
Operating pressure		0 ... 7 bar
Operating temperature		10 ... 50°C
Medium		Inert or corrosive liquids and gases that are compatible with the materials.
Shifting time (ISO 12238)		ON < 15 ms – OFF < 15 ms
Mounting position		Any
MATERIALS IN CONTACT WITH MEDIA		
Body		PEEK
Seals		FKM – EPDM – FFKM
Inner parts		Stainless steel (no contact with media)
ELECTRICAL SPECIFICATIONS		
Voltage		6 ... 24 V DC
Voltage fluctuation range		±10%
Power consumption		2 W
Duty cycle		100%
Electrical connection		DIN 43650 connector (9.4 mm), DIN EN 175301-803 C (8 mm), 300 mm wires
Degree of protection		IP65 with connector
SPECIAL SOLUTIONS AVAILABLE ON REQUEST		

Rocker valve

Media-separated solenoid valve with rocker mechanism

MR16 SERIES



APPLICATION

Valve for controlling aggressive gases and liquids.

FEATURES

- Compact design with flange or pipe connection
- Low power consumption
- Very low dead space volume
- Ideal for medical apparatus and analytical instruments

SPECIFICATIONS

TECHNICAL SPECIFICATIONS		MR16 SERIES
Function		2-way NC/NO, 3-way, universal
Type		Rocker valve
Pneumatic connection		M6, UNF 1/4" x 28
Nominal diameter		1.6 mm
Cv value		0.05
Operating pressure		-0.8 ... 3 bar
Operating temperature		5 ... 45°C
Medium		Water, ultra-pure water, aggressive liquids
Shifting time (ISO 12238)		ON < 15 ms – OFF < 15 ms
Mounting position		Any
MATERIALS IN CONTACT WITH MEDIA		
Body		PEEK
Seals		FKM
Inner parts		Stainless steel (no contact with media)
ELECTRICAL SPECIFICATIONS		
Voltage		12 V, 24 V DC
Voltage fluctuation range		±10%
Power consumption		5.3/1 W (power safe electronics)
Duty cycle		100% duty cycle
Electrical connection		300 mm wires
Insulation class		130 (B)
SPECIAL SOLUTIONS AVAILABLE ON REQUEST		

Rocker valve

Media-separated rocker valve, electrically operated,
3/2-way, universal

LDV SERIES



APPLICATION

Media-separated rocker valve for use with neutral or aggressive liquids and gases in the fields of analytics and medical technology. There is no risk of moving parts rubbing together and causing contamination. As a result, the purity of the medium is ensured.

FEATURES

- Service life: 5 million switching cycles
- Pressure range: vacuum to 6 bar
- Compact dimensions plus a high flow rate
- Small interior volume of < 50 µl
- Minimal heat exchange between control unit and medium
- Hermetic seal between medium and actuator
- Good self-emptying properties and flushability

SPECIFICATIONS

TECHNICAL SPECIFICATIONS		LDV 15 MM SERIES
Function		3/2-way, universal
Type		Rocker valve
Pneumatic connection		Flanged version
Nominal diameter		0.8 mm, 1.2 mm, 1.6 mm
Flow rate		27 l/min, 47 l/min, 32 l/min at max. pressure, with air as the medium
Operating pressure		-0.5 ... 6 bar
Operating temperature		0 ... 50°C
Medium		Inert gases, oxygen, water, aggressive liquids
Shifting time (ISO 12238)		ON < 15 ms – OFF < 15 ms
Mounting position		Any
MATERIALS IN CONTACT WITH MEDIA		
Body		PEEK
Seals		FKM, EPDM, FFKM
Inner parts		Stainless steel (no contact with media)
ELECTRICAL SPECIFICATIONS		
Voltage		6 V, 12 V, 24 V DC
Voltage fluctuation range		±10%
Power consumption		4/1 W (power safe electronics)
Duty cycle		100% duty cycle
Electrical connection		Plug
Degree of protection		IP65
SPECIAL SOLUTIONS AVAILABLE ON REQUEST		

Diaphragm isolated valve

Direct acting, media-separated solenoid valve with isolation diaphragm

MKB3 SERIES



APPLICATION

This valve is suitable for controlling aggressive liquid and gaseous media in analytical and medical technology applications.

FEATURES

- Slim design
- For vacuum applications
- Can be mounted downstream of the piping
- Patented one-handed mounting
- Counterpressure up to 2.5 bar

SPECIFICATIONS

TECHNICAL SPECIFICATIONS		MKB3 SERIES
Function		2/2-way, NC
Type		Direct acting diaphragm isolated valve
Pneumatic connection		M6, UNF 1/4" x 28
Nominal diameter		1.5 mm
Kv value		0.57 l/min with water
Operating pressure		-0.8 ... 2.5 bar
Operating temperature		5 ... 50°C
Medium		Water, pure water, aggressive liquids and gases
Shifting time (ISO 12238)		ON < 15 ms – OFF < 15 ms
Mounting position		Any
MATERIALS IN CONTACT WITH MEDIA		
Body		PPS
Inner parts		FKM, EPDM
ELECTRICAL SPECIFICATIONS		
Voltage		24 V DC
Voltage fluctuation range		±10%
Power consumption		2.5/1 W (power safe electronics)
Duty cycle		100% duty cycle
Electrical connection		With 300 mm wire ends
Insulation class		130 (B)
SPECIAL SOLUTIONS AVAILABLE ON REQUEST		

Solenoid valve

Direct acting solenoid valve with isolation diaphragm made of PTFE

MAB1/MAG1 SERIES



APPLICATION

This 3/2-way solenoid valve is suitable for use as a dosing and switchover valve in medical technology and analytical applications.

FEATURES

- Compact design
- Low power consumption
- Pressure-balanced diaphragms
- PTFE is the only material that comes into contact with the media
- High flow rate

SPECIFICATIONS

TECHNICAL SPECIFICATIONS		MAB1/MAG1 SERIES
Function		3/2-way, 2/2 way, NC and universal
Type		Directly controlled diaphragm isolated valve
Pneumatic connection		M6
Nominal diameter		1.6 mm
Kv value		0.65 l/min with water
Operating pressure		-0.5 ... 3 bar
Operating temperature		Ambient 0 ... 50°C / Fluid 5 ... 60°C
Medium		Water, pure water, aggressive liquids
Mounting position		Any
MATERIALS IN CONTACT WITH MEDIA		
Body		PTFE
Seals		PTFE
Inner parts		Stainless steel (no contact with media)
ELECTRICAL SPECIFICATIONS		
Voltage		24 V DC
Voltage fluctuation range		±10%
Power consumption		2.3 W
Duty cycle		100% duty cycle
Electrical connection		300 mm wire ends
Insulation class		130 (B)
SPECIAL SOLUTIONS AVAILABLE ON REQUEST		

Solenoid valve

Isolation lever-operated solenoid valve

HMTB1/HMTG1 SERIES



APPLICATION

Solenoid valve for controlling water and chemical liquids

FEATURES

- Compact dimensions
- High corrosion resistance
- Valve body made of PPS
- Tube connections
- Integrated mounting bracket

SPECIFICATIONS

TECHNICAL SPECIFICATIONS	HMTB1/HMTG1 SERIES
Function	3/2-way universal, 2/2-way NC
Type	Rocker valve
Pneumatic connection	2 mm
Nominal diameter	1.6 mm
Kv value	0.4
Operating pressure	-0.5 ... 3 bar
Operating temperature	0 ... 55°C
Medium	Water, pure water, chemical liquids (provided they are compatible with the material)
Shifting time (ISO 12238)	ON < 15 ms – OFF < 15 ms
Mounting position	Any
MATERIALS IN CONTACT WITH MEDIA	
Body	PPS
Seals	FKM, EPDM, NBR
Inner parts	Stainless steel
ELECTRICAL SPECIFICATIONS	
Voltage	12 V, 24 V DC
Voltage fluctuation range	±10%
Power consumption	2.4 W (9.6 W at start)
Duty cycle	100% duty cycle
Electrical connection	Two 300 mm wires
Insulation class	120 (E)
SPECIAL SOLUTIONS AVAILABLE ON REQUEST	

Tube pinch valve

Electrically operated valve

HYN SERIES



APPLICATION

The valve enables media to be controlled without any bends.

FEATURES

- No dead space volume
- Easy replacement of tubes
- Wide range of tube diameters supported
- The pinch device enables a long tube service life

SPECIFICATIONS

TECHNICAL SPECIFICATIONS	HYN SERIES
Function	2/2-way, 3/2-way NO, NC, universal
Type	Tube pinch valve
Pneumatic connection	Ø 3 x Ø 1, Ø 5 x Ø 3, Ø 8 x Ø 6 mm
Operating pressure	-0.5 ... 5 bar
Operating temperature	5 ... 50°C
Medium	Water, pure water, chemical liquids (provided they are compatible with the material)
Shifting time (ISO 12238)	ON 0.5 s – OFF 0.5 s minimum interval
Mounting position	Any
MATERIALS IN CONTACT WITH MEDIA	
Body	POM (no contact with media)
Tube	Tube to be selected
Inner parts	Stainless steel (no contact with media)
ELECTRICAL SPECIFICATIONS	
Voltage	12 V, 24 V DC, 100 V AC
Voltage fluctuation range	±10%
Power consumption	4 ... 8 W with DC, 0.6 ... 0.14 W with AC
Duty cycle	100% duty cycle
Electrical connection	Two 300 mm wires
SPECIAL SOLUTIONS AVAILABLE ON REQUEST	

Tube pinch valve

Air-operated valve

HYA SERIES



APPLICATION

The valve enables media to be controlled without any bends.

FEATURES

- No dead space volume
- Easy replacement of tubes
- Wide range of tube diameters supported
- The pinch device enables a long tube service life

SPECIFICATIONS

TECHNICAL SPECIFICATIONS		HYA SERIES	
Function		2/2-way NC, NO, double-acting	
Type		Tube pinch valve	
Pneumatic connection		M5, Rc1/8"	
Nominal diameter		Ø 3 x Ø 6, Ø 6 x Ø 10, Ø 10 x Ø 5 mm	
Operating pressure		0.2 ... 5 bar	
Operating temperature		0 ... 40°C	
Medium		Water, pure water, chemical liquids (provided they are compatible with the material)	
Frequency		30 cycles/min	
Mounting position		Any	
MATERIALS IN CONTACT WITH MEDIA			
Body		No contact with media	
Seals		No contact with media	
Inner parts		No contact with media	
PNEUMATIC ACTUATION SPECIFICATIONS			
Voltage		Compressed air	
Pilot pressure		3.5 ... 5 bar	
Duty cycle		100%	
SPECIAL SOLUTIONS AVAILABLE ON REQUEST			

Metal diaphragm valve

Air-operated diaphragm valve

AGD01R/02R SERIES



APPLICATION
Valve for controlling process gas

- FEATURES**
- Compact dimensions
 - High corrosion resistance
 - Diaphragm made of Ni-Co alloy
 - Long service life
 - Manufactured under cleanroom conditions

SPECIFICATIONS

TECHNICAL SPECIFICATIONS	AGD01R/02R SERIES
Function	NC, NO
Type	Metal diaphragm
Pneumatic connection	1/4" JXR male/female, M5 actuation thread
Nominal diameter	0.8 mm, 1.0 mm, 1.3 mm
Cv value	0.1, 0.3, 0.65
Operating pressure	1.3 Pa (abs) x 10 ⁻⁶ ...9.90 bar
Operating temperature	5 ... 80°C
Medium	Inert gases, process gases
Pilot pressure	4 ... 6 bar
Mounting position	Any
MATERIALS IN CONTACT WITH MEDIA	
Body	Stainless steel
Seals	Ni-Co alloy
Inner parts	PCTFE
SPECIAL SOLUTIONS AVAILABLE ON REQUEST	

Microvalve technology 5 mm

Direct-acting shape memory valve, current-controlled

SERIES MVL-22

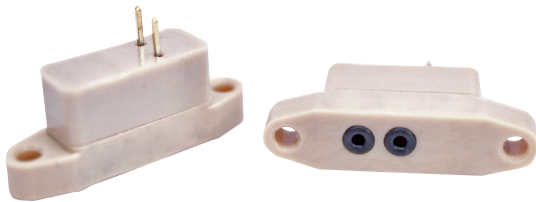

APPLICATION

The ultra-compact Normally Closed microvalve is only 5 mm wide and allows for the integration of multiple valves in a very small space. This enables the creation of miniaturized and highly functional fluidic systems. The valves are operated by current control, switch silently, and can also be proportionally controlled. Additionally, they are media-isolated, allowing for innovative solutions in microfluidic applications.

FEATURES

The valve is based on an innovative actuator technology using shape memory alloys. A shape memory alloy can be deformed in its cold state and will autonomously return to its original shape

when heated (through current control). This energy opens the valve by retracting the spring-loaded piston, allowing a liquid or gas to flow through the valve. A silicone membrane ensures that the medium remains separated from the actuation mechanism of the valve.

The valve is available in two different versions: Normally closed for pressure switching and normally open for vacuum switching.

SPECIFICATIONS

TECHNICAL SPECIFICATIONS	SERIES MVL-22
Function	2/2-way, NC
Design	direct-acting seat valve, media-isolated
Connection	Flange version or various base plates (see electronics and accessories)
Nominal size	0,8 mm
Cv value	0,005 m ³ /h
Flow rate (@Δp=1bar)	3'000 ml/min (Luft) // 90ml/min (water)
Internal volume	<6.5ul / <4ul
Operating pressure	3bar / Vacuum -0.7bar
Operating temperature	10 - 55°C
Medium	Medium inert gases, liquids
Switching time (on/off)	<50ms/<160ms @ Δp=1 bar
MATERIALS IN CONTACT WITH MEDIA	
Body	PEEK
Seals	Silicon, FKM
ELECTRICAL SPECIFICATIONS	
Continuous current	500 mA (bei 20 °C Umgebungstemperatur)
Electrical power consumption	0,25 W (bei 20 °C Umgebungstemperatur)
Continuous current	350 mA (bei 50 °C Umgebungstemperatur)
Electrical power consumption	0,125 W (bei 50 °C Umgebungstemperatur)
Peak and hold current	750 mA for 50 ms, 375 mA continuously @20°C ambient
Power consumption	< 0.6 W for 50 ms, < 0.15 W continuously @20°C ambient
SPECIAL SOLUTIONS AVAILABLE ON REQUEST	

Multivalve block for distributing or mixing media

Direct-acting shape memory valve, current-controlled

SERIES MPL-8CH-MODULAR-ECU-I



APPLICATION

The multi-valve block with 8 channels is ideal for the distribution or mixing of liquid samples. It has a minimal internal volume, which makes it indispensable in applications such as DNA synthesis.

FEATURES

The multi-valve block allows for independent distribution or mixing through individually controllable channels and offers 256 switching states in a minimal size. It has integrated control electronics and is lighter than conventional valve solutions. The multi-valve provides flexibility in handling liquids or gases. It can be used as an input selector to connect multiple inputs to one output, or as an output distributor to distribute one input to multiple out-

puts. The common channel in the multi-valve minimizes internal volume and reduces the risk of cross-contamination between different liquids or gases. Overall, the multi-valve offers versatility and convenience in handling up to eight different fluids or gases in fluid handling applications.

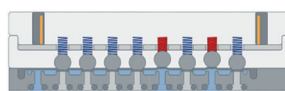
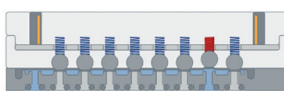

SPECIFICATIONS

TECHNICAL SPECIFICATIONS	SERIES MVL-22 / BV1101
Function	8-Kanal Multiventilblock
Size	14,5 x 32 x 11,5 mm
Nominal diameter	0,8 mm
Min. internal volume	35.3ul / alle Kanäle geschlossen
Additional internal volume	1 ul / pro Kanal
Max. internal volume	43.3ul / alle Kanäle offen
Operating pressure	1,8 bar
Flow rate (@ $\Delta p=1$ bar)	2500ml/min (Luft) // 50ml/min (Wasser)
Medium	Innertgase, Flüssigkeiten
Connection	Flange version
Weight	11,5 g
MATERIALS IN CONTACT WITH MEDIA	
Body	PEEK
Seals	Silicone, FKM
ELECTRICAL SPECIFICATIONS	
Electrical power consumption	(peak) 8x0,3 W
INTEGRATED ELECTRONICS	
Fully integrated electronics with microcontroller housed within. Isolated in potting compound according to ESD standards. Communication via I2C. Python library and sample code available. Electrical connection through pinout.	

Chip Actuators

Direct operated shape memory actuators, current-controlled

SERIES CA2001 AND CA0408

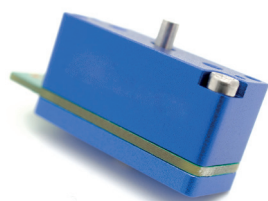

CA2001

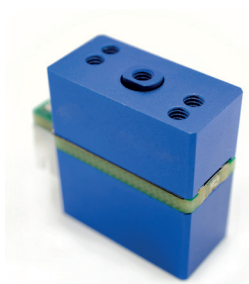

CA0408

APPLICATION

Our shape memory micro actuators offer a combination of significant forces and super-compact design. They have been specifically developed to enable motion on microfluidic chips and disposable cartridges. Additionally, they are suitable for controlling disposable valves, automating biochemical tests, and many other applications. With the actuators, you can realize innovative solutions such as smaller and intelligent point-of-care devices, medical equipment, as well as laboratory and organ-on-a-chip solutions or research setups. No matter where motion is needed in tight spaces, we are the right partner for you.

SPECIFICATIONS

TECHNICAL SPECIFICATIONS		SERIES CA2001
Type		Monostable linear actuator with 2mm stroke and maximum pulling force of 3.5N
Functionality		Push or pull, proportional control possible
Switching time (On)		1 s bei 1,9 A (ambient temperature 20 °C)
Switching time (Off)		6 s (ambient temperature 20 °C)
Continuous power		0,7 W
Dimensions		(WxLxH) 9 mm x 22 mm x 16 mm (excluding electrical connections)
Electrical connection		JST B2B-PH-K-S(LF)(SN)
Lifetime		> 25.000 cycles
TECHNICAL SPECIFICATIONS		SERIES CA0408
Type		Monostable linear actuator with 0.4 mm stroke and maximum pulling force of 8N
Functionality		Drücken oder Ziehen, proportionale Steuerung möglich
Switching time (On)		0,6 s bei 1,5 A (ambient temperature 20 °C)
Switching time (Off)		< 3 s (ambient temperature 20 °C)
Continuous power		0,65 W
Dimensions		(WxLxH) 9 mm x 23 mm x 20 mm (excluding electrical connections)
Electrical connection		JST B2B-PH-K-S(LF)(SN)
Lifetime		> 10.000 cycles
MATERIALS		
Housing		Anodized aluminium
Push/pull pin for CA2001		Stainless steel 1.4301
Push/pull piston for CA0408		Anodized aluminium, M2 internal thread interface
ELECTRICAL SPECIFICATIONS		
Use our ECU-S for easy evaluation of our actuators (see also Electronics and Accessories). With the ECU-S, you can control them manually by pressing a button or through the IO pin interface. We also offer an electronic control unit for integration into your custom circuit board. Contact us for more information.		

Electronics and Accessories

For current-controlled shape memory valves and actuators

ELECTRONIC CONTROL UNITS ECU-S & ECU-P2

The valves and chip actuators are operated by an actuator made of shape memory alloy. This actuator needs to be controlled by a current. For this reason, we offer easy-to-use electronic control units with a maximum constant current of 500mA. These electronic control units are intended for initial testing or laboratory setups.

ECU-S1



The small electronic control unit ECU-S1 is designed for controlling valves or actuators. It is lightweight and easy to use:

- Controls 1 valve or chip actuator
- Can be powered via USB B Micro or an external power supply
- Wide input voltage range of 4.5 V - 24 V

ECU-P2



The electronic control unit (ECU) enables the control of two normally closed valves or actuators. It offers various features:

- 2 output channels with measurement functions
- Fully programmable with USB and I2C
- User-friendly Python library for USB and I2C communication

ACCESSORIES

The extensive range of accessories allows for the assembly of valves in various configurations:

AD-MVL22-PEEK-4V



Adapter plate for 1 valve with PEEK hose connection fittings.

AD-MVL22-PEEK-2V-B16



Adapter plate for 2 valves with PEEK hose connection fittings, for mixing or distributing liquids in PEEK.

AD-MVL22-PEEK-1V



Adapter plate for 1 valve with LUER or IDEX tube connections in PEEK.

AD-MVL22-PEEK-2V



Adapter plate in PEEK for 2/4 valves with LUER or IDEX tube connections, for mixing or distributing liquids in PEEK.

AD-MVL22-PEEK-4V

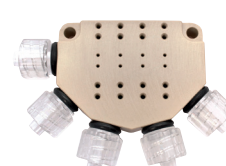

Micro pressure regulator

Made of brass, G1/8" and G1/4" connections

M SERIES



APPLICATION

This diaphragm pressure regulator is available in different versions and so can be supplied with or without secondary venting, with fine adjustment or with quick venting on the secondary side. The various sealing materials have been approved for contact with potable water, making it suitable for use with drinking water.

FEATURES

- Regulator can be supplied pre-adjusted or with a fixed setting
- Lightweight and compact design
- Precise and stable pressure regulation

SPECIFICATIONS

TECHNICAL SPECIFICATIONS	M SERIES
Medium	Compressed air, water and liquids
Type	Diaphragm regulator
Materials	Body: bright, uncoated brass Spring: stainless steel Seals: NBR with EPDM diaphragm
Seal	NBR with EPDM diaphragm
Connection	G1/8" – G1/4"
Weight	235 g
Manometer connection	G1/8"
Mounting type	Line installation, control panel installation (any)
Ambient temperature	10 ... 50°C
Operating pressure	Input pressure 0 ... 16 bar, output pressure 0.5 ... 10 bar
Nominal diameter	Air: Qn 480 NI/min Water: Kv 0.42 m ³ /h
SPECIAL DESIGNS AVAILABLE ON REQUEST	Various sealing materials, certificates can be provided on request

Micro pressure regulator

Made of plastic, G1/8" and G1/4" connections

T SERIES



APPLICATION

This plastic micro pressure regulator is suitable for applications that require a form of static pressure regulation that is both stable and affordable. All models feature an integrated quick venting valve on the secondary side for use between a valve and actuator.

FEATURES

- Extremely lightweight
- Compact design
- Affordable
- Precise and stable pressure regulation

SPECIFICATIONS

TECHNICAL SPECIFICATIONS	T SERIES
Medium	Compressed air
Type	Piston pressure regulator
Materials	Body + piston: thermoplastic; spring: stainless steel; inserts: brass
Seal	O-ring + plunger seal: NBR
Connection	G1/8"; G1/4"
Weight	95 g
Manometer connection	G1/8"
Mounting type	Line installation, control panel installation (any)
Operating temperature	-5°C ... 50°C
Input pressure	0 ... 12 bar
Output pressure	0.5 ... 10 bar (standard) 0 ... 2 bar 0 ... 4 bar 0.5 ... 7 bar
Secondary venting	With secondary venting (standard) Without secondary venting (all regulators feature a quick venting valve)

SPECIAL DESIGNS AVAILABLE ON REQUEST

Cartridge micro pressure regulator

Cartridge design, for oxygen

TC SERIES



APPLICATIONS

The cartridge design makes this regulator from the TC series perfect for applications where individual components need to be integrated into customer-specific pneumatic systems or valve blocks.

FEATURES

- Compact design
- Materials compatible with many different type of gaseous media
- Oxygen-compatible
- High performance
- Extremely small pressure drop

SPECIFICATIONS

TECHNICAL SPECIFICATIONS	TC SERIES
Function	Pressure regulator, without secondary venting
Type	Compact, moulded diaphragm
Pneumatic connection	G1/8" cartridge or 1/8" NPTF with aluminium block, M5
Flow rate	500 NI/min (P In 10 bar, P Out 4 bar)
Input pressure	0 ... 10 bar
Output pressure	0.03 ... 0.5 bar, 0.1 ... 2 bar, 0.15 ... 3 bar, 0.2 ... 4 bar
Operating temperature	-5 ... 50°C
Medium	Air, inert and medical gases, and oxygen
Repeat accuracy	±0.2% FS
Mounting position	Any
MATERIALS IN CONTACT WITH MEDIA	
Body	PPS, anodised aluminium
Seals	FKM
Inner parts	Stainless steel, PA
SPECIAL DESIGNS AVAILABLE ON REQUEST	To order the oxygen version, please add OX1 or OX2 at the end of the standard model designation.

Proportional valve

Directly operated solenoid valve, normally closed

AP SERIES

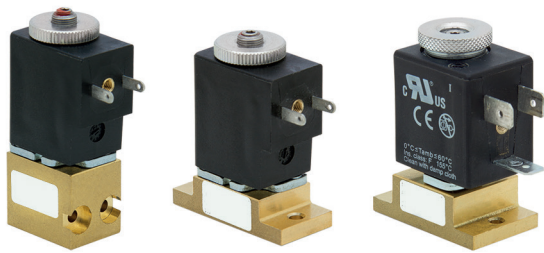

APPLICATION

Minimal friction is the hallmark of our directly operated proportional valves. The volume flow rate at the output is proportional to the input signal. The valves can also be used in vacuum mode. No minimum operating pressure is required.

FEATURES

- Used with a PWM signal
- Open-loop volume control
- Also vacuum-compatible
- FKM, NBR and EPDM seals

SPECIFICATIONS

TECHNICAL SPECIFICATIONS	AP SERIES
Function	2/2-way, NC
Type	Proportional, directly controlled
Pneumatic connection	G1/8" cartridge or 1/8" NPTF with aluminium block, M5
Nominal diameter	0.8 ... 2.4 mm
Flow rate	0 ... 135 NI/min @ 5 bar
Operating pressure	-1 ... 10 bar
Operating temperature	0 ... 60°C
Medium	Filtered oil-free air, inert gases, oxygen
Shifting time (ISO 12238)	ON < 10-43 ms – OFF < 11-41 ms
Mounting position	Any
MATERIALS IN CONTACT WITH MEDIA	
Body	Brass, PVDF
Seals	FKM, NBR, EPDM
Inner parts	Stainless steel
ELECTRICAL SPECIFICATIONS	
Voltage	12V DC, 24 V DC
Voltage fluctuation range	±10%
Power consumption	3.0 ... 6.5 W
Duty cycle	100% duty cycle
Electrical connection	Standard-compliant connector
SPECIAL DESIGNS AVAILABLE ON REQUEST	To order the oxygen version, please add OX2 at the end of the standard model designation.

Proportional valve

2/2-way, directly operated

A2-6500 SERIES



APPLICATION

Proportional control of air and inert gases.

FEATURES

- Variable flow rate that can be proportionally adjusted in relation to the control signal
- Available in three different nominal diameters

SPECIFICATIONS

TECHNICAL SPECIFICATIONS		A2-6500 SERIES
Function		2/2-way, NC
Type		Proportional valve
Pneumatic connection		Rc1/8"
Nominal diameter		1.6, 2.3 and 3.2 mm
Flow rate		0 ... 100 l/min
Operating temperature		0 ... 50°C
Medium		Air, inert gases
Mounting position		Any
MATERIALS IN CONTACT WITH MEDIA		
Valve body		Brass
ELECTRICAL SPECIFICATIONS		
Voltage		12 V DC, 24 V DC
Voltage fluctuation range		±10%
Power consumption		0 ... 4 W
Duty cycle		100% duty cycle
Electrical connection		300 mm wires
SPECIAL DESIGNS AVAILABLE ON REQUEST		

10 mm micro proportional valve

2/2-way solenoid valve, for flow rate control, NC

AKV SERIES



APPLICATION

This compact micro proportional valve is suitable for controlling the flow rate in the smallest of fluid systems.

FEATURES

- Compact design, just 10 mm wide
- Flow rate of up to 7 l/min
- Operating pressure of up to 7 bar
- Extremely low power consumption
- Oxygen-compatible

SPECIFICATIONS

TECHNICAL SPECIFICATIONS	AKV SERIES
Function	2/2-way, NC, directly controlled
Medium	Compressed air
Operating pressure	-1 ... 7 bar
Flow rate	0 ... 7 NI/min (@ 6 bar)
Effective cross-sectional area	0 ... 0.08 mm ²
Lubrication	Not supported
Operating temperature	-5°C ... 50°C
Fluid temperature	-5°C ... 50°C
Internal leakage	3 cm ³ /min
External leakage	1 cm ³ /min
Reproducibility	20%
ELECTRICAL SPECIFICATIONS	
Regulating range	0 ... 57 mA (with 25 mA opening point)
Power consumption	0.6 W
Voltage	12 V DC
SPECIAL DESIGNS AVAILABLE ON REQUEST	

Cartridge proportional valve

2/2-way, NC function, pressure-compensated versions
in widths of 16 mm and 20 mm

CP SERIES



APPLICATION

The directly controlled proportional valves from the CP series are suitable for open-loop flow control, e.g. when mixing gases or controlling volume flow rates. Thanks to the extremely compact cartridge design, they can be installed very close to the point of use.

FEATURES

- High flow rate and precision
- Low hysteresis
- Cartridge design
- Pressure-compensated

TECHNICAL SPECIFICATIONS	CP SERIES			
	16 MM, 2/2-WAY, NC	16 MM, 2/2-WAY, NC, PRESSURE-COMPENSATED	20 MM, 2/2-WAY, NC	20 MM, 2/2-WAY, NC, PRESSURE-COMPENSATED
Medium	Filtered compressed air, inert gases, oxygen	Filtered compressed air, inert gases, oxygen	Filtered compressed air, inert gases, oxygen	Filtered compressed air, inert gases, oxygen
Control	Proportional, directly controlled	Proportional, directly controlled	Proportional, directly controlled	Proportional, directly controlled
Pneumatic connection	Cartridge design	Cartridge design	Cartridge design	Cartridge design
Nominal diameter	1 ... 1.5 ... 2 mm	4.4 mm	3 ... 3.5 mm	4.4 mm
Unregulated flow rate	70 ... 80 ... 90 NI/min	120 NI/min	130 ... 150 NI/min	200 NI/min
Operating pressure	3 bar ... 5 bar ... 8 bar	2 bar (max. pressure 7 bar)	2.8 ... 2 bar	2.8 bar (max. pressure 6 bar)
Overload pressure	16 bar	10 bar	16 bar	16 bar
Linearity (5 ... 95%)	3% FS min	< 7% FS	5% FS	2% FS
Hysteresis	10% FS	< 20% FS	15% FS	15% FS
Repeat accuracy	5% FS	< 5% FS	5% FS	5% FS
Operating temperature	10°C ... 50°C	10°C ... 50°C	10°C ... 50°C	10°C ... 50°C
Materials in contact with media				
Body	Brass, stainless steel, PPS	Stainless steel, PPS	Brass, stainless steel, PPS	Brass, stainless steel, PPS
Seals	FKM	FKM (FDA, BAM)	FKM	FKM
Electrical specifications				
Control	PWM > 1000 Hz	PWM > 1000 Hz	PWM > 500 Hz	PWM > 1000 Hz
Voltage	6, 12, 24 V DC	6, 12, 24 V DC	6, 12, 24 V DC	6, 12, 24 V DC
Power consumption	3.1 W	3 W	3.7 W	4.2 W
Nominal resistance	11.8 – 37.6 – 184.7 ohms	11.8 – 47.7 – 184.7 ohms	6.4 – 25.1 – 102.1 ohms	6.4 – 25.1 – 102.1 ohms
Limiting current	410 – 238 – 103 mA	410 – 205 – 103 mA	615 – 313 – 154 mA	700 – 350 – 175 mA
Duty cycle	100% when used with air	100% when used with air	100% when used with air	100% when used with air
Electrical connection	300 mm wires, AWG 24	300 mm wires, AWG 24	300 mm wires, AWG 24	300 mm wires, AWG 24
Degree of protection	IP00 / IP40	IP00 / IP40	IP00 / IP40	IP00 / IP40
Switching life (full strokes)	50 million	50 million	50 million	50 million
Recommended control signal	PWM: 1000 Hz	PWM: 1000 Hz	PWM: 500 Hz	PWM: 1000 Hz
SPECIAL DESIGNS AVAILABLE ON REQUEST				

Signal generator

130 series PWM signal generator

130 SERIES



APPLICATION

This 130 series control unit is suitable for all proportional valves up to a maximum of 1 A. It proportionally converts a standard input signal of 0-10 V or 4-20 mA into a PWM output signal.

FEATURES

- Control of actuating current, max. 1 A
- Rising ramp and falling ramp
- 0-10 V and 4-20 mA control signal
- Regulation of min./max. current (span and offset)

SPECIFICATIONS

TECHNICAL SPECIFICATIONS	130 SERIES
Materials	Polycarbonate
Electrical connection	Terminals
Operating temperature	0 ... 50°C
Mounting position	Any
Electrical actuation	6 V ... 24 V DC (± 10%)
Power consumption	0.4 W (without valve)
Analogue input	0 ... 10 V, 4 ... 20 mA
Input resistance	> 30 kilohms with voltage input < 200 ohms with current flow
PWM output	120 Hz ÷ 11.7 KHz (fixed, depending on valve function)
Max. current strength (valve)	1 A
Protective circuit	Polarity reversal, short circuiting of outputs
Connection cable	5 ... 7.5 mm with seals only; 4 ... 6 mm with adapter and seals
Cable cross-section	26 ... 16 AWG / 0.13 ... 1.5 mm ²
Max. length of supply/signal cable	10 m
Max. length of valve connection cable	5 m
Degree of protection acc. to EN 60529	IP54
Ramp type	Adjustable from 0 to 5 s
Min. current strength, regulated	0% ... 40% FS
Max. current strength, regulated	50% ÷ 100% FS

Digital proportional flow control valve

Directly controlled, electrically operated, normally closed

860 SERIES



APPLICATION

The digital flow control valves from the 860 series offer unrivalled precision and a compact and straightforward design that is second to none. Each unit contains nine 2/2-way solenoid valves, all of which converge at the input and output ports. Each valve has a different nominal diameter and can be switched independently. This enables a proportional linear flow rate without any hysteresis. This valve technology is often used for precise flow control in technical medical devices.

FEATURES

- Shifting times < 1 ms
- Maximum frequency: 500 Hz
- Flow rate: 0.3 ... 750 l/min
- Pressure range: 0 ... 6 bar
- No hysteresis
- 100% repeat accuracy
- Actuated via PWM or 0 ... 10 V

SPECIFICATIONS

TECHNICAL SPECIFICATIONS		860 SERIES
Function		2/2-way, NC
Type		Proportional, directly controlled
Pneumatic connection		G1/8" or push-in fitting
Nominal diameter		Approx. 6 mm
Flow rate		0 ... 750 l/min
Operating pressure		0 ... 6 bar
Operating temperature		0 ... 50°C
Medium		Filtered oil-free air, inert gases, oxygen
Shifting times		ON < 1 ms – OFF < 1 ms
Mounting position		Any
MATERIALS IN CONTACT WITH MEDIA		
Body		Aluminium
Seals		FKM, NBR
Inner parts		Stainless steel
ELECTRICAL SPECIFICATIONS		
Voltage		24/5 V DC, speed-up
Voltage fluctuation range		±10%
SPECIAL DESIGNS AVAILABLE ON REQUEST		

Open frame controller

Modular proportional regulator

OPEN FRAME CONTROLLER



APPLICATION

The new proportional open frame controller is a modular platform for closed-loop control of the pressure, volume flow rate or position, and is suitable for Industry 4.0 applications. The system consists of two basic modules: a master and a slave. These can be combined with one another to suit individual requirements.

FEATURES

- Flow control via differential pressure sensors and calibration nozzles
- Pressure regulation via pressure sensors
- Pneumatic cylinder position control using a displacement measurement system

SPECIFICATIONS

TECHNICAL SPECIFICATIONS	OPEN FRAME CONTROLLER
Medium	Filtered oil-free air, inert gases and oxygen
Type	Modular, compact, directly controlled
Function	2/2-way, 3/3-way 2/2-way high flow (parallel)
Flow rate	Max. 90 NI/min
Input pressure	-1 ... 10 bar
Regulated pressure	-1 ... 10 bar
Connections	G1/8"
Seals	NBR, FKM, EPDM
Mounting position	Any
Analogue input signal	0-10 V or 4-20 mA
Analogue output signal	0-10 V
Supply voltage	24 V DC +/-10% or 12 V DC +/-5%
Current consumption	0.3 A (master module), 0.3 A (slave module)
Electrical connection	CANopen CiA 301, RS485, RS232, IO-Link (Port Class B)
Degree of protection	IP20
Hysteresis	Pressure regulation <= 3% FS; flow control <= 2% FS
Repeat accuracy	Pressure regulation version <= 1% FS; for pressures lower than 1 bar <= 2% FS Flow control version <= 2% FS
Resolution	Flow control version <= 2% FS
Operating temperature	0 ... 60°C (low temperatures on request)
PWM frequency	1 kHz (adjustable)
Weight	300 g
Linearity	Pressure regulation <= 2% FS; flow control <= 5% FS

SPECIAL DESIGNS AVAILABLE ON REQUEST

Digital servo proportional valve

3/3-way servo valve for flow control (LRWD2), pressure regulation (LRPD2) and positioning (LRXD2)

LR SERIES



APPLICATION

For fast and precise control of flow rates, positioning and pressures.

FEATURES

- Digital version, configurable via micro USB port
- Rotary slide principle, metallic sealing
- High flow rate
- Electronically controlled, ensures precise flow metering
- Can be mounted on a DIN rail
- Positioning version available

SPECIFICATIONS

TECHNICAL SPECIFICATIONS	LR SERIES
Function	3/3-way, closed centre position, motor-operated with rotary slide
Medium	Filtered oil-free compressed air according to ISO 8573-1, class 3.4.3; inert gases
Auxiliary power	24 V DC +/- 10%, smoothed, max. 0.8 A
Input signal	+/-10 V DC 0 ... 10 V 4 ... 20 mA
Hysteresis	Approx. 1% FS LRWD2 – 0.2% LRPD2
Linearity	1% FS LRWD2 – 0.3% LRPD2
Operating temperature	0 ... 50°C
Relative humidity	Max. 90%
Mounting direction	Any
Controlled variables	Pressure, flow rate, position
Operating pressure	-0.9 / 10 bar
Nominal diameter	4 mm and 6 mm
Leakage	< 1% of maximum flow
Electrical connection	M12 8-pin connector
Interface for hardware configuration	Micro USB

SPECIAL DESIGNS AVAILABLE ON REQUEST

Electronic micro proportional controller

Proportional controller for pressure regulation

K8P SERIES

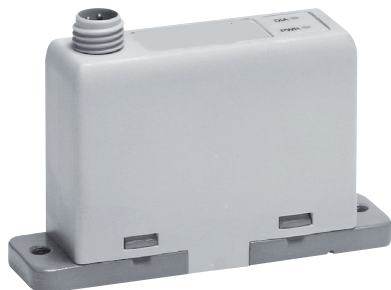

APPLICATION

For proportional control of air and inert gases and keeping these at a constant pressure, e.g. in cylinders or pinch valves. For sensitive control of diaphragm valves.

FEATURES

- Highly dynamic and precise
- Fast response time
- Minimal energy required
- Adaptive self-control
- Flexible in operation
- Compact design
- Oxygen-compatible

SPECIFICATIONS

TECHNICAL SPECIFICATIONS	K8P SERIES	
Medium	Filtered oil-free compressed air according to ISO 8573-1, class 3.4.3, oxygen, inert gases (argon, nitrogen)	
Pressure	Regulated pressure 0.5 ÷ 10 bar 0.15 ÷ 3 bar 0.35 ÷ 7 bar 0.05 ÷ 1 bar	Max. input pressure 11 bar 4 bar 8 bar 1.5 bar
Operating temperature	0 ... 50°C	
Analogue input signal	0 ... 10 V DC 4 ... 20 mA, ripple ≤ 0.2%	
Analogue output signal	0 ... 10 V [feedback]	
Impedance of control signal	20,000 Ω for 0-10 V version 250 Ω for 4-20 mA version	
Max. flow rate	12 l/min with a regulated pressure of 6 bar, input pressure 10 bar 6 l/min with a regulated pressure of 3 bar, input pressure 4 bar 8 l/min with a regulated pressure of 7 bar, input pressure 8 bar 2 l/min with a regulated pressure of 1 bar, input pressure 1.5 bar	
Supply voltage/power	24 V ... ~1 W	
Function	3/2-way, NC	
Linearity	≤ ± 1% FS	
Hysteresis	±0.5% FS	
Resolution	±0.5% FS (depending on input signal)	
Repeat accuracy	±0.5% FS	
Connection	M8 connector (4-pin)	
Degree of protection	IP65 (with standard base plate or when used individually) IP51 (with compact base plate and compact base plate for external pressure measurement)	
SPECIAL DESIGNS AVAILABLE ON REQUEST		

Electronic proportional pressure regulator

With constant status monitoring, two different sizes

PRE SERIES



APPLICATION

The proportional pressure regulators from the PRE series feature CoilVision technology. This is used to continuously monitor the solenoid valves inside the regulator to ensure they are working properly, thereby preventing any faults.

The recorded data is transmitted wirelessly so that it can be logged, collated and analysed. A piece of software enables this data to be displayed.

FEATURES

- CoilVision technology for diagnostics and status analysis
- Oxygen-compatible
- Customisable control parameters
- IO-Link version
- Version with or without display
- Protection class: IP65

SPECIFICATIONS

TECHNICAL SPECIFICATIONS	PRE SERIES		
Medium	Filtered oil-free air of class 7.4.4 according to ISO 8573.1:2010, inert gases and oxygen		
Reference standards	CE; RoHS; ATEX; UL/CSA		
Controlled variable	Pressure		
Function	3-way		
Flow rate	PRE104 0 ... 1100 NI/min; PRE238 0 ... 4600 NI/min		
Min. and max. regulated pressure	0 ... 1 bar (0-14.5 PSI) 0.03 ÷ 4 bar (0.43-58 PSI)	0.05 ÷ 10.3 bar (0.72-150 PSI) 0.05 ÷ 7 bar (0.72-101.5 PSI)	0.05 ÷ 6 bar (0.72-87 PSI)
Max. input pressure	2 bar 5 bar 11 bar		
External sensor connection (optional)	Input signal 0 ... 10 V DC or 4 ... 20 mA		
Resolution	0.3% FS (size 1); 0.6% FS (size 2)		
Temperature of medium	0 ... 50°C		
Operating temperature	0 ... 50°C		
Connections	G1/4", G3/8", 1/4" NPTF		
Materials	Body: aluminium – cover: plastic – seals: NBR or FKM		
Supply voltage	24 V DC		
Input signal	0 ... 10 V; 4 ... 20 mA; 5-bit digital; IO-Link		
Hysteresis	0.5% FS (size 1); 0.7% FS (size 2)		
Current consumption	Max. 0.5 A (hypothetical current supply of min. 1 A)		
Electrical connections	M12 5-pin connector (IO-Link) M12 8-pin connector (analogue and PreSet) M12 12-pin connector (version with external sensor)		
Repeat accuracy	0.4% FS		
Linearity	0.4% FS		
Modularity	Can be interlocked with MD filter series		
IO-Link version of the PRE	V1.1 according to standard IEC 61131-9 / 61131-2		
Output signal	0 ... 5 V DC and 4 ... 20 mA (as standard on version with analogue input signal)		
SPECIAL DESIGNS AVAILABLE ON REQUEST			

Electronic proportional pressure regulator

Two sizes

PME SERIES



APPLICATION

The proportional pressure regulators from the PME series are the ideal solution for industrial applications that call for precise pressure regulation within a system.

These new pressure regulators offer a high level of pneumatic power.

FEATURES

- Manifold version
- Version with integrated outlet valve
- Modular with MD series
- Configuration app with NFC technology
- Compact

SPECIFICATIONS

TECHNICAL SPECIFICATIONS	PME SERIES	
Medium	Filtered oil-free air of class 7.4.4 according to ISO 8573.1:2010, inert gases and oxygen	
Controlled variable	Pressure	
Function	3-way	
Flow rate (Qn)	PME104 – 1100 NI/min	PME238 – 4600 NI/min
Min. and max. regulated pressure	0.05-10.3 bar (0.72-150 PSI) 0.05-7 bar (0.72-101.5 PSI)	0.05-6 bar (0.72-87 PSI)
Max. input pressure	11 bar	
External sensor connection (optional)	Input signal 0-10 V DC or 4-20 mA	
Resolution	0.3% FS (size 1); 0.6% FS (size 2)	
Temperature of medium	0 ... 50°C	
Operating temperature	0 ... 50°C	
Connections	G1/4" – G3/8" – 1/4" NPTF	
Materials	Body: aluminium – cover: plastic – seals: NBR or FKM	
Supply voltage	24 V DC	
Input signal	0-10 V (2); 4-20 mA (4)	
Hysteresis	0.5% FS (size 1); 0.7% FS (size 2)	
Current consumption	Max 0.5 A (allow for a current supply of at least 1 A)	
Electrical connections	M12 5-pin connector	
IP protection class	IP65	
Repeatability	0.4% FS	
Linearity	0.4% FS	
Modularity	With MD series	

SPECIAL DESIGNS AVAILABLE ON REQUEST

Flow controller

RAPIFLOW compact flow controller

FCM PLASTIC AND STAINLESS STEEL BODY



APPLICATION

For controlling air, nitrogen, argon, oxygen, mains gas, methane and propane as well as hydrogen and helium.

FEATURES

- A single device that combines flow sensor technology with proportional control and valve functions to ensure the required flow rate.
- High-speed control thanks to the platinum sensor chip manufactured using silicon micromachining.
- Reliable flow control, reproducibility: $\pm 1\%$ FS
- Accuracy: $\pm 3\%$ FS
- Digital display installed for viewing the control status at a glance
- Flow value indicated digitally in three-digit format

SPECIFICATIONS

TECHNICAL SPECIFICATIONS			FCM SERIES
Medium			Air, nitrogen, argon, oxygen, mains gas, methane, propane, hydrogen and helium
Flow rate			500 ml/min ... 100 l/min
Control	Valve operation method		Proportional solenoid valve – normally closed
	Control range	9500 ... 0020	$\pm 5\%$ can be set within 0.5 s
	No. of paths	0050 ... 0100	$\pm 5\%$ can be set within 1 s
	Accuracy		Within $\pm 3\%$ FS
	Reproducibility		Within $\pm 1\%$ FS
	Temperature properties		Within $\pm 0.2\%$ of final value/ $^{\circ}\text{C}$ (base temperature 25°C)
	Pressure properties		Within $\pm 1\%$ of final value per 98 kPa (standard differential pressure reference)
Temperature of operating environment, humidity of operating environment			0 ... 50°C , 90% RH or lower (non-condensing)
I/O	Input signal		IO-Link
Flow rate display	Display method		3-digit 7-segment LED, display accuracy: control accuracy ± 1 digit
	Display range, display resolution		See separate table
Integrated functions			See separate table
Power supply	Power supply voltage		24 V DC $\pm 10\%$ (stabilised power supply with a residual ripple of 1% or less)
	Current consumption		200 mA or less (connection type A)
Mounting arrangement			Vertically/horizontally without restrictions
Wetted area materials	H6/H8		Polyamide resin, fluoro rubber, stainless steel, alumina, semiconductor silicon, soldering
	8A/UF		Stainless steel, fluoro rubber, alumina, semiconductor silicon, soldering
Weight	H6/H8		Approx. 200 g
	8A/UF		Approx. 480 g
Degree of protection			IP40 in accordance with IEC standards, or equivalent

Proportional pressure regulator

Available in two sizes: PMP1 and PMP2
Connections G1/4" – G3/8" – 1/4" NPTF

PMP 202/204 SERIES



APPLICATION

Pneumatically controlled regulator for stabilising pressure fluctuations in chemical liquids and pure water supply components. When the product is combined with an electro-pneumatic regulator, the set pressure can also be adjusted remotely.

FEATURES

- Manifold version
- Version with integrated outlet valve
- Modular with MD series
- Configuration app with NFC technology
- A compact and indispensable solution

SPECIFICATIONS

TECHNICAL SPECIFICATIONS	PMP 202 SERIES	PMP 402 SERIES
Medium	Pure water, chemical liquids	Pure water
Fluid temperature	10 ... 60°C	10 ... 90°C
Test pressure MPa	0.75	1
Max. working pressure	5 bar	5 bar
Adjustable pressure	0.2 ... 3 bar	0.7 ... 4 bar
Operating pressure	0 ... 4 bar	0 ... 4.5 bar
Recommended flow rate	0.2 ... 5 l/min	2 ... 20 l/min
Operating connection	Rc1/8"	Rc1/8"
Ambient temperature	10 ... 60°C	10 ... 60°C
Mounting arrangement	Any	Any
Connection	Ø 6 tube connection (integrated fitting) Ø 1/4" pipe connection (integrated fitting) Outer Ø 10 pipe connection (integrated fitting) Ø 3/8" pipe connection (integrated fitting)	3/4" pipe connection (integrated fitting) (Outer diameters of 1" and 1/2" available as options)

Inline filter

Rc1/8", Rc1/4", R1/8", R1/4"
 Ø 4, Ø 6, Ø 8 push-in fitting

FCS SERIES

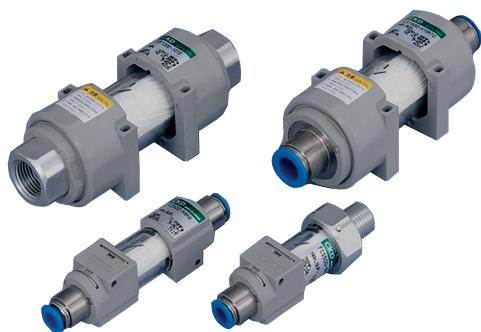

APPLICATION
 Physicochemical analytical apparatus

FEATURES
 The inline clean filter features a hollow fibre membrane for the filter element. It offers high performance in every respect – from its filtration performance, flow rate, pressure loss and service life right through to the amount of installation space required.

SPECIFICATIONS

TECHNICAL SPECIFICATIONS		STANDARD ELEMENT, RESIN TYPE	PIPING WITH EXTER- NAL THREAD	P9 ELEMENT, STAINLESS STEEL	
		FCS500	FCS500	FCS500-88-P90 FCS500-88-P94	FCS500-88-P90 FCS500-88-P94
Medium		Compressed air, N2			
IN side hole size	Ø 4, Ø 6 and Ø 8	Ø 4, Ø 6 and Ø 8 or R1/8" and R1/4"	Rc1/8"	Rc1/4"	
OUT side hole size			Rc1/8"	Rc1/4"	
Test pressure	15 bar		22 bar (compressed air), 15 bar (N2)		
Differential pressure-resistant	5 bar		5 bar		
Operating pressure	1 ... 10 bar		1 ... 15 bar		
Ambient/fluid temperature	5 ... 50°C		5 ... 45°C		
Filtration rate µm	0.01 (separation efficiency 99.99%)				
Flow rate	50 / 80 l/min	50 / 80 l/min	50 l/min	80 l/min	
Weight	45 g		100 g		
Material	Body	Polyamide	Polyamide, aluminium (alumite treatment)	Stainless steel	
	Housing	Clear polyamide	Clear polyamide	Stainless steel	
	Element	Polypropylene & urethane			
Assembly/inspection/packaging	Integrated production under cleanroom conditions				
Cleaning	Degreasing				

Antibacterial filter

Bacteria removal filter

SFS10 SERIES



APPLICATION

Ideal for circuits that blow directly onto food. Provides clean air that is free of bacteria.

FEATURES

The silver ions in the antibacterial filter adsorb and destroy bacteria by inhibiting the effect of bacterial enzymes.

SPECIFICATIONS

TECHNICAL SPECIFICATIONS	SFS10 SERIES	
Medium	Compressed air, nitrogen gas (N ₂) and carbon dioxide (CO ₂)	
IN side hole size	Ø 8 push-in fitting or G1/4" thread	
OUT side hole size	Ø 8 push-in fitting or G1/4" thread	
Nominal pressure	15 bar	
Withstandable differential pressure	5 bar	
Operating pressure	1 ... 9 bar	
Ambient/fluid temperature °C	5 ... 45°C	
Filtration µm	0.01 (separation efficiency 99.99%)	
Flow rate l/min (ANR)	300 ... 400	
Weight g	Push-in fitting	Thread
	150	110
Assembly/inspection/packaging	Integrated production under cleanroom conditions	
Cleaning	Degreasing	
Replacement of elements	1 year (6000 hours) or in the event of a 0.1 MPa pressure drop	

Flow sensor

Compact design

FSM3 SERIES



APPLICATION

For measuring gas flows in the semiconductor, biochemistry, food, pharmaceutical and process industries.

FEATURES

- Plastic and stainless steel housing
- Flow range: 15 ml/min to 1000 l/min
- Settings can be made for 5 different gases as well as gas mixtures
- Very low pressure loss thanks to MEMS sensor technology
- Highly precise with a fast response time

SPECIFICATIONS

TECHNICAL SPECIFICATIONS		FSM3 SERIES
Flow direction	U	Unidirectional
	B	Bidirectional
Display		4-digit + 4-digit, 2-colour LCD
Applications	Media	Clean air, compressed air, nitrogen gas
		Argon, carbon dioxide and gas mixture (argon + carbon dioxide)
	Flow rate	15 ml/min ... 1000 l/min
	Temperature	0 ... 50°C (no condensation)
	Nominal pressure	10 bar
	Test pressure	10 bar
Storage temperature		-10 ... 60°C
Measuring accuracy	Accuracy	Within $\pm 3\%$ FS
	Repeatability	Within $\pm 1\%$ FS
Response time		50 ms or less
Switch output		NPN open collector output (50 mA or less, voltage drop 2.4 V or less)
		PNP open collector output (50 mA or less, voltage drop 2.4 V or less)
Analogue output		1 to 5 V voltage output (connected load impedance 50 k Ω or more)
		4 ... 20 mA current output (connected load impedance 0 ... 300 Ω)
Voltage supply		12 ... 24 V DC (10.8 ... 26.4 V) residual ripple of 1% or less
		24 V DC (21.6 ... 26.4 V) ripple rate of 1% or less
Current consumption		45 mA or less
Supply cable		\varnothing 3.7, AWG 26 or equivalent x 5-core (connector), insulator outer diameter 1.0
Functions		(1) Gas type selection, (2) Function for copying setting, (3) Flow rate integration, (4) Peak hold, etc.
Degree of protection		IP40 or equivalent (IEC standard)
Protective circuit		Protection against power polarity reversal, protection against switching output polarity reversal, short-circuit protection at the switching output
Vibration resistance		10 ... 150 Hz, 100 m/s ² , 2 hours in each of the directions X, Y and X
EMC Directive		EN 55011, EN 61000-6-2, EN 61000-4-2/3/4/6/8
Mounting arrangement		Vertically/horizontally without restrictions

Miniature flow sensor

Miniature flow switch

FSM-X SERIES



APPLICATION

For measuring gas flows in the semiconductor, biochemistry, food, pharmaceutical and process industries.

FEATURES

- Plastic housing
- Flow range: 50 ml/min to 10 l/min
- Air and N₂ gas
- Very low pressure loss thanks to MEMS sensor technology
- Highly precise with a fast response time

SPECIFICATIONS

TECHNICAL SPECIFICATIONS		FSM-X SERIES
Flow range		0.05 ... 10 l/min
Compatible fluids		Clean air, nitrogen
Max. operating pressure		2 bar
Min. operating pressure		-0.9 bar
Test pressure		3 bar
Ambient temperature/humidity		0 ... 50°C
Temperature of medium		0 ... 50°C (no condensation)
Output		One-point analogue output (1 to 5 V voltage output, connected load impedance of 50 kΩ and more)
Accuracy of linearity		No characteristic
Response time		5 ms or less (8 ms or less at 10 l/min)
Power supply voltage		24 V DC (21.6 ... 26.4 V DC) ripple rate of 1% or less
Installation/ assembly	Mounting arrangement	Vertically/horizontally without restrictions
	Straight pipeline section	Not required
Vibration resistance		10 ... 150 Hz, composite amplitude 1.5 mm, max. 10 G, 2 hours in each of the directions X, Y and Z
EMC Directive		EN 61000-6-4, EN 61000-6-2
Weight	Bright, uncoated	Approx. 4 g (cable not included)
	H04	Approx. 17 g (cable not included)

Pressure switch and pressure sensor

Compact electronic pressure switch

PPE SERIES

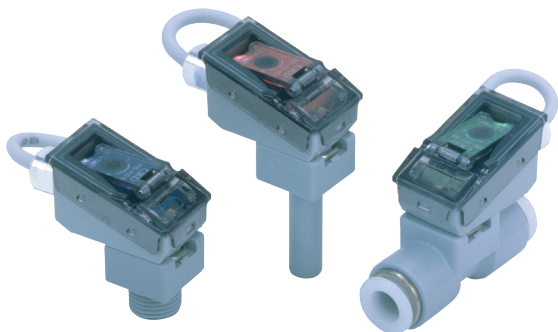

APPLICATIONS

The PPE series is a range of semiconductor pressure switches featuring pressure switch trimmer adjustment. The series has been developed for use in pneumatic/vacuum systems. The design is compact and there are three connection options (R1/8", Ø 6 connector, Ø 6 push-in fitting).

FEATURES

- Semiconductor pressure sensor
- 2-wire
- High test pressure
- Integrated protective circuit for protection against polarity reversal/overcurrent
- Various connection sizes
 - R1/8"
 - Ø 6 connector
 - Ø 6 push-in fitting

SPECIFICATIONS

	PPE-V01	PPE-P01	PPE-P10
Nominal pressure	-1 bar ... 0 bar	0 bar ... 1 bar	0 bar ... 10 bar
Type colour code	Red	Green	Blue
Pressure-sensitive elements	Diffusion semiconductor pressure sensor		
Medium	Air/non-corrosive gas		
Test pressure	6 bar	3 bar	15 bar
Repeatability	±1% FS		
Hysteresis	3% FS or less		
Temperature properties	±3% FS		
Load voltage	10 ... 30 V DC		
Load current	5 ... 50 mA		
Internal voltage drop	4 V or less		
Leakage current	1 mA or less		
Indicator light	Yellow LED lights up during operation		
Lead wire length	3 m as standard (oil-resistant, 2-core, 0.15 mm ² vinyl cable, insulation outer diameter Ø 1.0)		
Ambient temperature during operation	0 (32°F) to 50°C (122°F) (no freezing)		
Vibration resistance	10 ... 55 Hz, composite amplitude 1.5 mm, 4 hours in each of the directions X, Y and Z		
Degree of safety	IEC standard IP65 or equivalent		
Piping type	R1/8" piping, Ø 6 connector, Ø 6 push-in fitting		
Weight	PPE- -6/-H6-B: approx. 37 g, PPE- -H6: approx. 42 g		

Flow sensor

FLUEREX (Karman vortex flow sensor)

WFK2 SERIES



APPLICATIONS

Physicochemical analytical apparatus

FEATURES

Karman vortex flow sensor covering a range of 0.4 to 250 l/min. Switch settings can be made for various outputs and IO-Link communication is supported. The product features a flow temperature measurement function as standard and supports fluid temperatures of up to 95°C, making it ideal for various cooling water monitoring applications.

SPECIFICATIONS

	WFK2-005	WFK2-020	WFK2-050
Connection size Rc, G, NPT	3/8", 1/2", 3/4"		
Connection material	Stainless steel		
Medium	Pure and industrial water Fluorinated fluids: Fluorinert™ (FC.3283, FC-40), Galden® (HT135, HT200), Novec™ 7300, Opteon™ SF10		
Max. operating pressure	10 bar		
Test pressure	15 bar		
Manual valve (stopcock) internal leakage ml/min	0		
Permissible counterpressure of manual valve (stopcock)	3 bar		
Ambient temperature	0 ... 50°C		
Media temperature	-10 ... 95°C		
Flow rate range	0.4 ... 5 l/min	1.6 ... 20 l/min	4 ... 50 l/min
Repeatability	Accuracy of analogue output: ±2.5% of final value, display accuracy: ±2.5% of final value ±1 digit (min. display unit)		
Temperature properties	±5% FS		
Low flow rate	5% of FS		
Accumulated flow range	99,999 l or 99,999 m3 (unit is selectable) is reset when the power supply is switched off		
Integrated pulse frequency l/pulse	0.1, 0.5, 1	0.1, 0.5, 1, 10	0.5, 1, 10, 50
Pressure loss (when the medium is water)	0.07 (FS)	0.05 (FS)	0.05 (FS)
Response time	0.25, 0.5, 1, 5, 10 (initial value 1)		
Temperature measurement °C	-10 ... 100°C		
Accuracy	0 ... <50: accuracy of analogue output: ±2, display accuracy: ±1±2 unit (min. display unit 1)		
	50 ... 100: accuracy of analogue output: ±3, display accuracy: ±3±1 unit (min. display unit 1)		
Display	2-screen LCD display, direct flow rate: 3 digits, fluid temperature: 2 digits, integrated flow: 5 digits with screen rotation		

Fittings

We offer a wide range of fittings and accessories. The numerous different series – made of nickel-plated brass, stainless steel and plastic – cater for all kinds of applications. The push-in fittings, quick screw fittings, compression fittings, accessories and one-hand couplings are available in a wide range of versions from M3 to 1". The patented Sprint® system ensures optimum leak tightness even if the connections are detached and reattached several times under difficult usage conditions.

OX series push-in fittings and accessories for medical gas applications



- Nickel-plated brass
- Diameters: 4, 6, 8 mm
- Connections: M5, G1/8", G1/4", R1/8", R1/4"
- Seals: FKM O-ring with oxygen-compatible lubrication
- Suitable for tubes made of PA, PU, FEP

Rapid series 1000 quick screw fittings



- Material: nickel-plated brass
- Tube: 5/3, 6/4, 8/6, 10/8, 12/10, 15/12.5 mm
- Connections: M5, M6, M12 x 1, M12 x 1.25, G1/8" G1/4", G3/8", G1/2", R1/8", R1/4", R3/8", R1/2"
- Seals: NBR O-ring, PTFE thread seal

2000 series screw fitting accessories



- Nickel-plated brass
- Diameters: 4, 6, 8, 10, 12 mm
- Connections: M5, G1/8", G1/4", G3/8", G1/2", G3/4", G1", R1/8", R1/4", R3/8", R1/2", R3/4", R1"

5000 series one-hand couplings



- Nickel-plated brass
- Diameters: Ø 5 and 7 mm
- Connections: G1/8", G1/4", G3/8", G1/2"
- Plastic pipes: 6/4, 8/6, 10/8
- Rubber tubes: 6 x 14, 8 x 17, 10 x 19, 13 x 23
- Seals: stainless steel spring/ball, NBR O-ring

Series 6000 Superrapid push-in fittings



- Nickel-plated brass
- Diameters: 3, 4, 5, 6, 8, 10, 12, 14, 16 mm
- Connections: M3, M5, M6, M7, G1/8", G1/4", G3/8", G1/2", G3/4", R1/8", R1/4", R3/8", R1/2"
- Seals: PTFE or FKM/EPDM on thread, FKM/EPDM on pipe seal

X6000 series Superrapid stainless steel push-in fittings



- Stainless steel 1.4404
- Diameters: 4, 6, 8, 10, 12 mm
- Connections: G1/8", G1/4", G3/8", G1/2", R1/8", R1/4", R3/8", R1/2"
- Seals: FKM, food-compatible

Series 7000 Medical GRIPfit push-in fittings



- Technopolymer, Nickel-plated brass, Stainless steel
- Diameters: 4, 6, 8, 10 mm
- Connections: M5, G1/8", G1/4", G3/8", G1/2"
- Seals: EPDM for oxygen application

Series 7000 Superrapid push-in fittings



- Plastic, brass insert, nickel-plated brass collet
- Diameters: 4, 6, 8, 10, 12, 16 mm
- Connections: M5, M7, G1/8", G1/4", G3/8", G1/2", G3/4"
- Seals: NBR O-ring, NBR thread seal

8000 series dual seal Superrapid push-in fittings



- Nickel-plated brass
- Diameters: 4, 6, 8, 10, 12 mm
- Connections: G1/8", G1/4", G3/8", G1/2"
- Seals: NBR O-ring, NBR thread seal

H8000 series dual seal Superrapid push-in fittings



- For dusty and dirty environments
- Nickel-plated brass
- Diameters: 4, 6, 8, 10, 12 mm
- Connections: G1/8", G1/4", G3/8", G1/2"
- Seals: FKM/EPDM on thread and on pipe seal, FKM thread seal

Resistance table

	HOUSING MATERIALS													SEAL MATERIALS								
	Aluminium	Brass	Polyamide (PA)	Stainless steel	Polyvinylidene fluoride (PVDF)	Bronze	Delrin (POM)	PVC	PBTP – PETP	PEEK	Polypropylene	Ryton (PPS)	Kel-F (PCTFE)	Buna (NBR, HNBR)	Viton (FKM, FPM)	Teflon (PTFE)	EPDM	Kalrez (FFKM, FFKM)	MO silicone	Neoprene (CR)	Polyurethane (PUR)	
Acetylene						x																
Vinegar	x						x							x	x							x
Acetone				x										x	x				x	x	x	
Acetic acid		x	x			x	x	x			x				x				x	x	x	
Boric acid							x															x
Carbonic acid																			x			
Citric acid		x				x	x															
Hydrochloric acid 15-20%	x	x	x	x		x	x				x			x					x	x	x	
Concentrated hydrochloric acid	x	x	x	x		x	x	x			x			x	x				x	x	x	
Chromic acid		x	x			x	x	x						x					x	x	x	
Formic acid	x		x			x	x	x			x			x	x							x
3 molar phosphoric acid	x		x				x				x			x						x	x	
Concentrated phosphoric acid	x	x	x	x		x	x	x			x			x					x	x		
3-molar nitric acid	x	x	x			x	x	x	x	x	x			x					x	x	x	
Concentrated nitric acid		x	x			x	x	x			x	x		x			x		x	x	x	
3-molar sulphuric acid	x	x	x	x		x	x		x		x			x					x	x	x	
Concentrated sulphuric acid	x	x	x				x	x			x	x		x			x		x	x	x	
Water	x																					x
Chlorine water	x		x				x	x						x			x		x	x	x	
Seawater	x	x													x							x
Distilled, demineralised water		x																				
Hydrogen peroxide		x	x			x	x							x	x				x	x	x	
Alcohol – butanol								x	x										x			x
Alcohol – ethanol									x						x							x
Alcohol – methanol								x							x							x
Alcohol – propanol																						x
Gaseous ammonia (dry)		x				x		x	x						x				x			x
Ammonia (solution)		x				x													x			x
Air																						
Nitrogen																						
Benzene								x			x			x			x		x	x	x	
Petrol											x											
Gaseous butane																	x		x			x
Liquid butane																	x		x			
Dry gaseous chlorine		x					x				x			x			x		x	x	x	
Wet gaseous chlorine	x	x	x	x		x					x			x			x		x	x	x	
Chloroform								x	x		x	x	x	x			x		x	x	x	
Carbon dioxide (dry)																						
Carbon dioxide (wet)																						
Ethane																						

	HOUSING MATERIALS											SEAL MATERIALS									
	Aluminium	Brass	Polyamide (PA)	Stainless steel	Polyvinylidene fluoride (PVDF)	Bronze	Delrin (POM)	PVC	PBTP – PETP	PEEK	Polypropylene	Ryton (PPS)	Kel-F (PCTFE)	Buna (NBR, HNBR)	Viton (FKM, FPM)	Teflon (PTFE)	EPDM	Kalrez (FFKM, FFKM)	MO silicone	Neoprene (CR)	Polyurethane (PUR)
Ether																					
Ethylene						x													x	x	
Ethylene glycol		x																			
Freon 12										x								x	x		
Freon 21					x	x	x				x	x		x		x		x			
Freon 22										x				x		x	x	x			x
Methane gas																x		x	x	x	
Natural gas																x					x
Gas oil, diesel																x		x	x	x	
Glycol			x																		x
Animal fat										x											
Mineral grease								x		x											x
Silicone grease (thermal paste)								x											x		
Vegetable fat																x		x			
Hydrogen												x							x		
Hydrogen sulphide		x				x	x		x					x	x				x	x	
Sodium hydroxide	x			x		x	x		x						x				x		x
Sodium hypochlorite	x	x	x			x	x			x	x			x			x		x	x	x
Kerosene										x							x		x		
Methane (gaseous)											x				x				x		x
Methyl ethyl ketone (MEK)																			x	x	x
Carbon monoxide																					
Naphtha								x		x							x				
Animal oil										x											
Hydraulic oil																	x		x		
Mineral oil								x		x							x				
Silicone oil								x		x											
Vegetable oil								x									x			x	x
Oil, ASTM 1 and 3									x								x		x		
Heavy fuel oil																	x		x	x	x
Oxygen (gas)	x																				
Ozone		x	x				x				x			x						x	
Perchloroethylene		x				x	x	x			x						x		x	x	x
Propane (gaseous)									x		x								x	x	x
Nitrous oxide		x				x									x						
Toluene								x		x				x			x		x	x	x
Terpentine								x	x		x								x	x	x
Trichloroethylene							x	x		x	x	x		x			x	x	x	x	x
Steam > 150°C			x				x	x	x		x			x	x				x	x	x
Xenon																					x

Compatible x Not compatible

Technical information

Valve selection data

It is crucial to select the right valve when planning a system. The following factors must be taken into account:

- Valve type
- Piping dimensions and connection type
- Flow coefficient Kv
- Permissible static pressure and operating pressure differential
- Medium and temperature of medium
- Ambient temperature
- Ambient atmosphere
- Operating frequency
- Electrical supply: current type and power

The following table will help you to define the valve as precisely as possible:

Valve design				
Type:	<input type="checkbox"/> 2/2-way, normally open	<input type="checkbox"/> 2/2-way, normally closed	<input type="checkbox"/> 3/2-way, normally open	<input type="checkbox"/> 3/2-way, normally closed
	<input type="checkbox"/> 3/2-way, universal			
Material:	Housing	Inner parts		Diaphragms
Dimensions:	Connection	Threaded connection	Nominal diameter	Kv
Technology:	<input type="checkbox"/> Isolation diaphragm	<input type="checkbox"/> Isolation lever	<input type="checkbox"/> Rocker mechanism	<input type="checkbox"/> Bellows
	<input type="checkbox"/> Tube pinch device	<input type="checkbox"/> Directly operated	<input type="checkbox"/> Other	
Operating data:				
Medium		Additives etc.		
Min. temperature of medium (°C)		Viscosity (cSt)		
Max. temperature of medium (°C)		Viscosity (cSt)		
Operating pressure (bar)		Min.	Max.	Normal
Perm. pressure loss (bar) (ΔP)		Min.	Max.	
Flow rate (m ³ /h, l/min, kg/h, etc.)		Min.	Max.	
Perm. internal leakage rate (cc/min, etc.)				
Perm. external leakage rate (cc/min, etc.)				
Pressure of control medium (valve)		Min.	Max.	
Ambient temperature (°C)		Min.	Max.	
Ambient conditions				
Electrical specifications				
Voltage		Frequency (Hz)		Solenoid class
Type of operation:	<input type="checkbox"/> Continuous operation	<input type="checkbox"/> Intermittent duty	Duration: "Operating state"	
			"Non-operating state"	
Solenoid connection:	<input type="checkbox"/> Line socket	<input type="checkbox"/> Mini connector	<input type="checkbox"/> Wire end	<input type="checkbox"/> Other
Electrical consumption (W):				
In the case of direct current, please specify the supply equipment (e.g. battery, rectification).				
General data				
Number of cycles			Service life	
Desired cable entry				
Mounting position				
Approvals and certificates of conformity				
ISO 10993		Biocompatibility		Other
Special specifications				
<input type="checkbox"/> Manual override		<input type="checkbox"/> Manual reset		Type
<input type="checkbox"/> Mounting bracket		<input type="checkbox"/> Meter		<input type="checkbox"/> Other

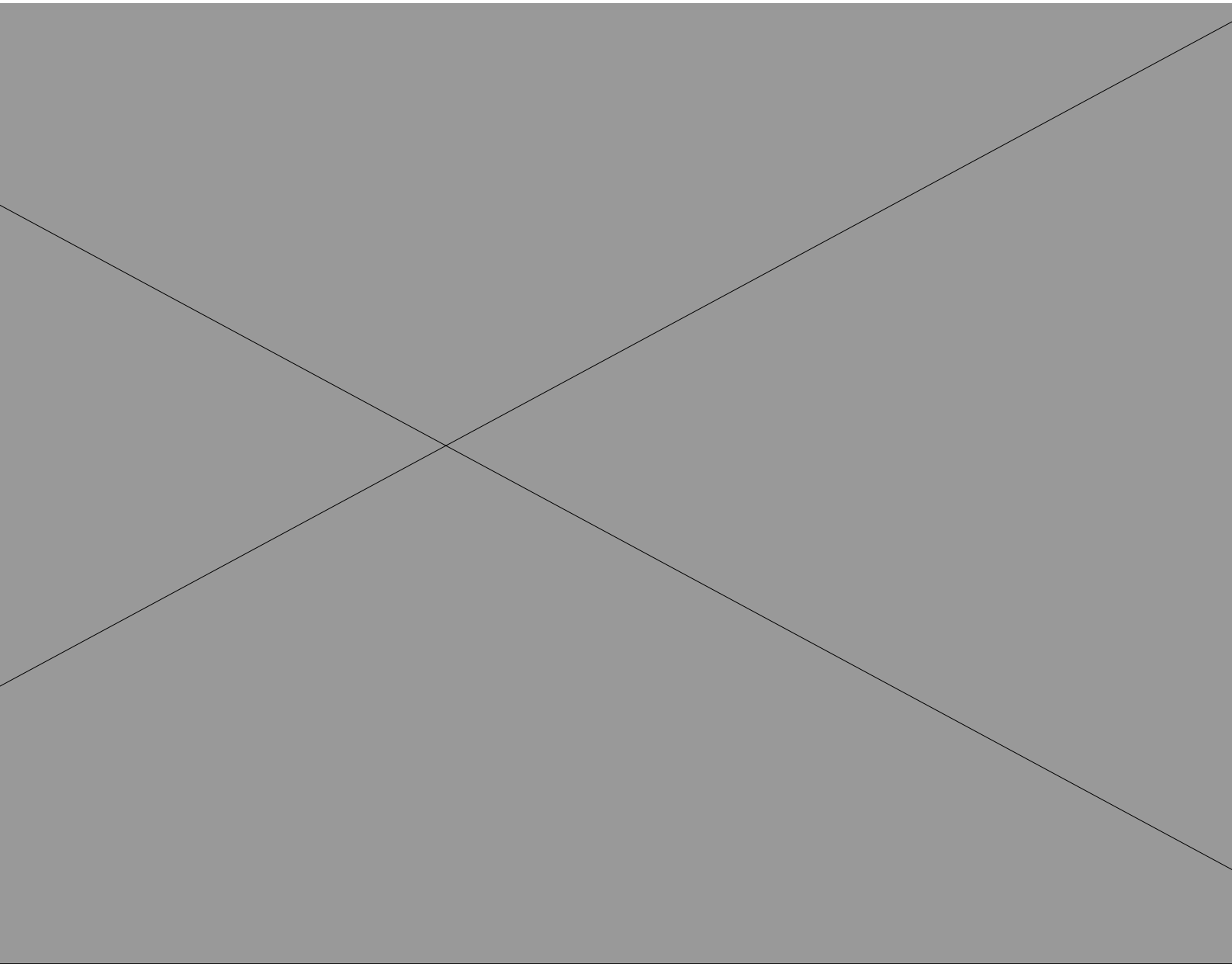

Allmendstrasse 26
CH-8320 Fehraltorf

Phone +41 44 877 50 11

info.bag@bibus.ch
www.lifescience.bibus.com

