

# FLOW AIDS



THE WORLDWIDE LEADER IN VIBRATION TECHNOLOGY





# ROTARY PNEUMATIC VIBRATORS

**PRODUCT SERIES**

BALL VIBRATORS  
**S**



**APPLICATION**

Silos  
Hoppers  
Piping  
Chutes  
Compacting

**POWDER**

**Dry powders**  
Granules  
Plastics  
Sand  
Ashes  
Cement  
Lime

**FEATURES**

Filter sleeve cleaning.  
Suitable for outdoor use.  
Resistant to oxidation.  
Atex II2G c Tx  
Atex II2D c Tx

**BENEFITS**

Economical  
Low air consumption  
High frequency vibration

ROLLER VIBRATORS  
**OR**



Silos  
Hoppers  
Piping  
Chutes  
Concrete compaction

**Hygroscopic powders**

Cement  
Concrete  
Sand  
Foundry sand

Compact and robust design.  
Suitable for outdoor use.  
Resistant to oxidations.  
Atex II2G c Tx  
Atex II2D c Tx

High centrifugal force  
Low air consumption  
High frequency vibration  
Suitable for high temperature

TURBINE VIBRATORS  
**OT**



Silos  
Hoppers  
Piping  
Chutes

**Food powders**

Sugar  
Bicarbonate  
Phosphate  
Sodium

Suitable for food and pharmaceutical applications.  
Resistant to oxidation.  
Atex II2G c Tx  
Atex II2D c Tx

High performance  
Silent  
Low air consumption

## APPLICATIONS

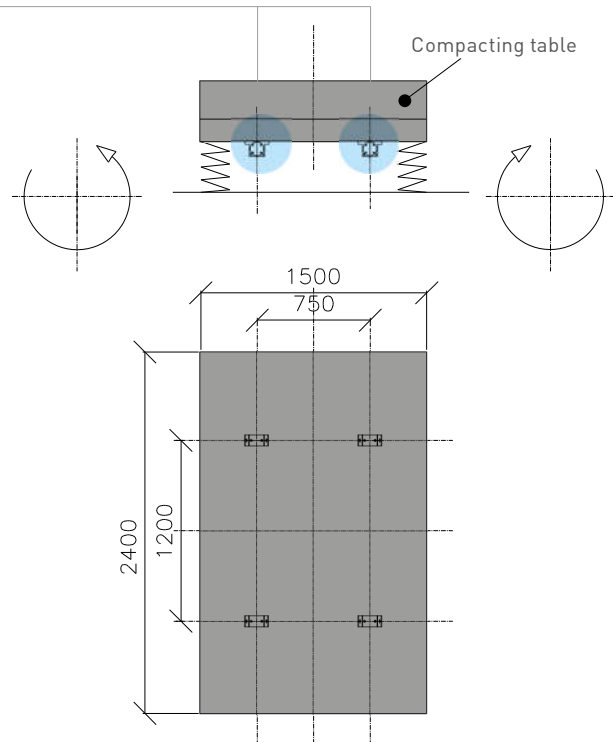
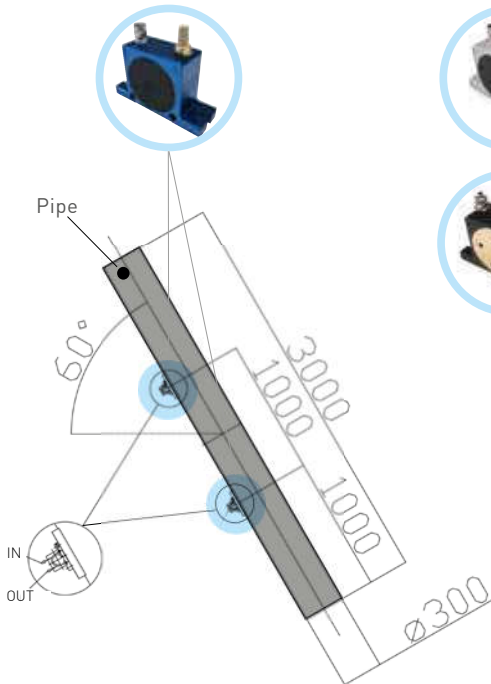



# S - Rotary pneumatic vibrators - Ball

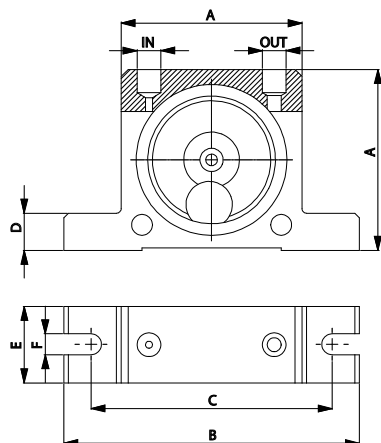

DIMENSIONAL SPECIFICATIONS

MODEL	A		B		C		D		E		F		IN-OUT	WEIGHT	
	mm	in	mm	in	mm	in	mm	in	mm	in	mm	in		kg	lb
S8	50	1.97	86	3.39	68	2.68	12	0.47	20	0.79	7	0.28	1/8" BSPP	0.13	0.29
S10	50	1.97	86	3.39	68	2.68	12	0.47	20	0.79	7	0.28	1/8" BSPP	0.13	0.29
S13	65	2.56	113	4.45	90	3.54	16	0.63	25	0.98	9	0.35	1/4" BSPP	0.26	0.57
S16	65	2.56	113	4.45	90	3.54	16	0.63	28	1.10	9	0.35	1/4" BSPP	0.30	0.66
S20	80	3.15	128	5.04	104	4.09	16	0.63	33	1.30	9	0.35	1/4" BSPP	0.53	1.17
S25	80	3.15	128	5.04	104	4.09	16	0.63	38	1.50	9	0.35	1/4" BSPP	0.63	1.39
S30	100	3.94	160	6.30	130	5.12	20	0.79	45	1.77	11	0.43	3/8" BSPP	1.13	2.49
S36	100	3.94	160	6.30	130	5.12	20	0.79	50	1.97	11	0.43	3/8" BSPP	1.34	2.95

MODEL	VIBRATION			C.F. MAX						AIR CONSUMPTION					
	Vpm			2 bar (29 psi)		4 bar (58 psi)		6 bar (87 psi)		2 bar (29 psi)		4 bar (58 psi)		6 bar (87 psi)	
	2 bar (29 psi)	4 bar (58 psi)	6 bar (87 psi)	kg	lb	kg	lb	kg	lb	l/min*	CF/min	l/min*	CF/min	l/min*	CF/min
S8	25500	31000	35000	13	29	26	57	36	79	83	2.9	145	5.1	195	6.9
S10	22500	28000	34000	25	55	47	103	71	156	92	3.2	150	5.3	200	7.1
S13	15000	18500	22500	32	70	55	121	87	191	94	3.3	158	5.6	225	7.9
S16	13000	17000	19500	45	99	80	176	110	242	122	4.3	200	7.1	280	9.9
S20	10500	14500	16500	72	158	122	268	172	378	130	4.6	230	8.1	340	12.0
S25	9200	12200	14000	93	205	157	345	205	451	160	5.7	290	10.2	425	15.0
S30	7800	9700	12500	151	332	247	543	321	706	215	7.6	375	13.2	570	20.1
S36	7300	9000	10000	206	453	315	693	405	891	260	9.2	475	16.8	675	23.8

\* Indicates in l/min the total air consumption normalized at the rated pressure.

## S - ROTARY PNEUMATIC VIBRATORS - BALL

**APPLICATION** Hopper and silo - screen - vibrating table - chute

**POWDER** Dry and granular

**PROBLEM SOLVING** Friction reduction - separation

## FEATURES

**DUTY CYCLE** Continuous

**WORKING PRESSURE** From 2 bar to 6 bar (from 29 psi to 87 psi)

**PNEUMATIC CIRCUIT** Filter + flow control valve + lubrication + 3/2 ways valve

**AIR SUPPLY QUALITY** Class 5.4.4.

**WORKING TEMPERATURE** From -20 °C to 200 °C (from -4 °F to 392 °F)

**MAX NOISE LEVEL** 90 dB(a)

**TECHNOLOGY** Rotary vibration - high frequency

**ATEX** II 2D C TX  
II 2G C TX

**MATERIAL** Aluminium body and zinc plate cover





# OR - Rotary pneumatic vibrators - Roller

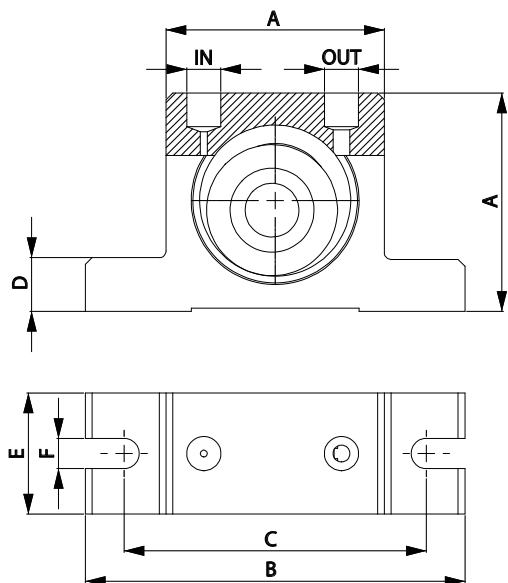

DIMENSIONAL SPECIFICATIONS

MODEL	A		B		C		D		E		F		IN-OUT	WEIGHT	
	mm	in	mm	in	mm	in	mm	in	mm	in	mm	in		kg	lb
OR50	50	1.97	86	3.39	68	2.68	12	0.47	30	1.18	7	0.28	1/8" BSPP	0.37	0.81
OR65	65	2.56	113	4.45	90	3.54	16	0.63	36	1.42	9	0.35	1/4" BSPP	0.76	1.67
OR80	80	3.15	128	5.04	102	4.02	16	0.63	40	1.57	9	0.35	1/4" BSPP	1.27	2.79
OR100	100	3.94	160	6.30	130	5.12	20	0.79	52	2.05	11	0.43	1/4"-3/8" BSPP	2.60	5.72

MODEL	VIBRATION			C.F. MAX						AIR CONSUMPTION					
	Vpm			2 bar (29 psi)		4 bar (58 psi)		6 bar (87 psi)		2 bar (29 psi)		4 bar (58 psi)		6 bar (87 psi)	
	2 bar (29 psi)	4 bar (58 psi)	6 bar (87 psi)	kg	lb	kg	lb	kg	lb	l/min*	CF/min	l/min*	CF/min	l/min*	CF/min
OR50	21000	25000	29500	188	413	281	619	355	780	78	2.8	144	5.1	204	7.2
OR65	19000	22000	26000	235	516	439	966	552	1215	100	3.5	198	7.0	296	10.5
OR80	14000	16000	21500	342	752	587	1292	624	1373	122	4.3	255	9.0	378	13.3
OR100	6750	9750	11000	289	637	604	1329	783	1722	132	4.7	284	10.0	412	14.5

\* Indicates in l/min the total air consumption normalized at the rated pressure.

## OR - ROTARY PNEUMATIC VIBRATORS - ROLLER

APPLICATION Hopper and silo - piping - chute - concrete compaction

POWDER Hygroscopic

PROBLEM SOLVING Friction reduction - compaction

## FEATURES

DUTY CYCLE Continuous

WORKING PRESSURE From 2 bar to 6 bar (from 29 psi to 87 psi)

PNEUMATIC CIRCUIT Filter + flow control valve + lubrication + 3/2 ways valve

AIR SUPPLY QUALITY Class 5.4.4.

WORKING TEMPERATURE From -20 °C to 200 °C (from -4 °F to 392 °F)

MAX NOISE LEVEL <90 dB(a)

TECHNOLOGY Roller vibration - high frequency and centrifugal force

ATEX II 2D C TX  
II 2G C TX

MATERIAL Aluminium body and brass cover



This information is furnished without warranty, representation, inducement or license of any kind. It is accurate to the best OLI knowledge or is obtained from sources believed to be accurate. OLI therefore assumes no legal responsibility. The latest and most updated information are available online.



# OT - Rotary pneumatic vibrators - Turbine

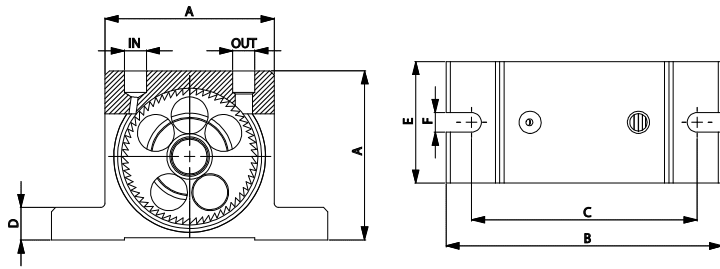

DIMENSIONAL SPECIFICATIONS

MODEL	A		B		C		D		E		F		IN-OUT	WEIGHT	
	mm	in	mm	in	mm	in	mm	in	mm	in	mm	in		kg	lb
OT8	50	1.97	86	3.39	68	2.68	12	0.47	33	1.30	7	0.28	1/8" BSPP	0.25	0.55
OT10														0.26	0.56
OT10S														0.26	0.58
OT13	65	2.56	113	4.45	90	3.54	16	0.63	42	1.65	9	0.35	1/4" BSPP	0.57	1.24
OT16														0.58	1.28
OT16S														0.61	1.35
OT20	80	3.15	128	5.04	104	4.09	16	0.63	56	2.20	9	0.35	1/4" BSPP	1.09	2.40
OT25														1.12	2.46
OT25S														1.20	2.64
OT30														2.20	4.84
OT36	100	3.94	160	6.30	130	5.12	20	0.79	73	2.87	11	0.43	3/8" BSPP	2.30	5.06
OT36S														2.53	5.57

MODEL	VIBRATION			C.F. MAX						AIR CONSUMPTION					
	Vpm			2 bar (29 psi)		4 bar (58 psi)		6 bar (87 psi)		2 bar (29 psi)		4 bar (58 psi)		6 bar (87 psi)	
	2 bar (29 psi)	4 bar (58 psi)	6 bar (87 psi)	kg	lb	kg	lb	kg	lb	l/min*	CF/min	l/min*	CF/min	l/min*	CF/min
OT8	34000	38000	42000	110	242	205	451	292	641	45	1.6	81	2.9	110	3.9
OT10	26000	33000	38000	105	231	171	377	252	554	45	1.6	81	2.9	110	3.9
OT10S	17200	23400	26000	72	159	147	323	187	410	45	1.6	81	2.9	110	3.9
OT13	24500	28500	31000	202	444	263	579	300	659	122	4.3	204	7.2	285	10.1
OT16	18000	20000	21000	194	427	239	527	264	581	122	4.3	204	7.2	285	10.1
OT16S	11500	15000	17500	129	285	196	431	234	516	122	4.3	204	7.2	285	10.1
OT20	14500	19000	23000	251	552	404	888	526	1157	184	6.5	318	11.2	452	16.0
OT25	13200	15500	17000	244	537	336	740	508	1117	184	6.5	318	11.2	452	16.0
OT25S	9000	11000	13500	214	471	335	738	483	1063	184	6.5	318	11.2	452	16.0
OT30	11000	12500	14500	351	771	721	1586	781	1718	322	11.4	542	19.1	749	26.5
OT36	8500	11500	12000	341	751	698	1536	749	1648	322	11.4	542	19.1	749	26.5
OT36S	6000	7000	8500	406	893	706	1554	754	1660	322	11.4	542	19.1	749	26.5

\* Indicates in l/min the total air consumption normalized at the rated pressure.

## OT - ROTARY PNEUMATIC VIBRATORS - TURBINE

APPLICATION	Hopper and silo - screen - vibrating table - chute - concrete consolidation
POWDER	Dry and granular [food] - concrete
PROBLEM SOLVING	Friction reduction - separation - consolidation

## FEATURES

DUTY CYCLE	Continuous
WORKING PRESSURE	From 2 bar to 6 bar (from 29 psi to 87 psi)
PNEUMATIC CIRCUIT	Filter + flow control valve + 3/2 ways valve
AIR SUPPLY QUALITY	Class 5.4.1.
WORKING TEMPERATURE	From -20 °C to 120 °C (from -4 °F to 248 °F)
MAX NOISE LEVEL	<90 dB(a)
TECHNOLOGY	Turbine vibration - high frequency and centrifugal force
ATEX	II 2D C TX II 2G C TX
MATERIAL	Aluminium body



This information is furnished without warranty, representation, inducement or license of any kind. It is accurate to the best OLI knowledge or is obtained from sources believed to be accurate. OLI therefore assumes no legal responsibility. The latest and most updated information are available online.