

# MF LINE



Raccordi Automatici per Applicazioni Food and Beverage  
Push-in Fittings for Food and Beverage Applications  
Raccords instantanés pour le domaine alimentaire et des boissons  
Steckverschraubungen für Lebensmittel-und Getränkeanwendungen



Certified to  
NSF/ANSI 169



I

GB

F

D

MF è il Raccordo Automatico studiato e certificato per applicazioni Food and Beverage. Completamente realizzato in ottone a basso contenuto di piombo, il raccordo della serie MF è certificato NSF secondo lo standard 169 per il contatto con acqua, the e caffè; risulta pertanto la soluzione ottimale per l'industria delle macchine del caffè e del vending. Completa le certificazioni del raccordo serie MF anche la conformità secondo lo standard NSF/ANSI 372 che garantisce la rispondenza dell'ottone ai tenori di piombo massimi concessi per il contatto con acqua potabile (U.S.Safe Drinking Water Act).

MF is a push-to-connect fitting designed and certified for Food and Beverage applications. MF fitting is made of brass with low lead content and it is NSF certified according to the 169 standards for contact with water, tea and coffee. This makes MF fitting The Right Solution for the coffee and vending machines industry. On top of the 169 NSF/ANSI Certificate, the MF fitting boasts also the NSF/ANSI 372 brass compliance with the maximum lead content standards allowed for contact with drinking water (U.S. Safe Drinking Water Act).

MF est la connexion automatique conçue et certifiée pour les applications alimentaires et de boissons. Entièrement en laiton à faible teneur en plomb, le raccord série MF est certifié NSF selon la norme 169 pour le contact avec l'eau, le thé et le café; c'est donc la solution optimale pour l'industrie du café et des distributeurs automatiques. La certification des raccords de la série MF est également conforme à la norme NSF/ANSI 372 qui garantit la conformité du laiton aux niveaux maximum de plomb autorisés pour le contact avec l'eau potable (U.S.Safe Drinking Water Act).

MF ist eine Steckverschraubung spezifisch entwickelt für Anwendungen im Bereich Nahrungsmittel und Getränke. Die Verschraubung besteht aus Messing mit geringem Bleigehalt und ist nach NSF 169 Richtlinie für den Kontakt mit Wasser, Tee und Kaffee zertifiziert. Diese Baureihe ist daher die perfekte Lösung für Kaffeemaschinenhersteller oder Getränkeautomaten. Die NSF Zertifizierung wird auch mit der Konformität gemäß NSF/ANSI 372 Richtlinie ergänzt, die die Tauglichkeit von Messing und den maximal erlaubten Bleianteil für Trinkwasserkontakt garantiert (U.S. Safe Drinking Water Act).

# MF

1	2	3
Corpo Body Corps Körper	Pinza aggraffaggio Gripping collet Pince Spannzange	Guarnizioni Seals Joint d'étanchéité Dichtung
Ottone EN 12164 CW510L Conforme NSF/ANSI 372 Brass EN12164 CW510L Compliant NSF/ANSI 372 Laiton EN12164 CW510L, Conforme NSF/ANSI 372 Messing EN12164 CW510L, NSF/ANSI 372 konform	Ottone EN 12164 CW510L Conforme NSF/ANSI 372 Brass EN12164 CW510L Compliant NSF/ANSI 372 Laiton EN12164 CW510L, Conforme NSF/ANSI 372 Messing EN12164 CW510L, NSF/ANSI 372 konform	FPM Conforme FDA FDA Compliant FPM Conforme FDA, FPM FDA konform, FPM

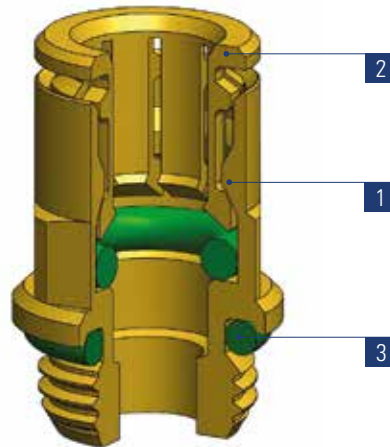

	M5x0,8	G1/8	G1/4
4	●	●	
6	●	●	●
8		●	●

## SPECIFICHE TECNICHE

**Tubi di collegamento consigliati:**  
Tubi termoplastici per applicazioni Food.  
**Tolleranze accettabili sui tubi:**  
+/- 0,07 mm fino a Ø 8 mm.

**Campi di applicazione:**  
Applicazioni nel settore Food and Beverage.

## DATA SHEET

**Recommended tubings:**  
Any tubing recommended for Food and Beverage  
**Acceptable Tolerances on the tubings:**  
+/- 0,07 mm up to Ø 8 mm.

**Application fields:**  
Food and Beverage Applications.

## REINSEIGNEMENTS TECHNIQUES

**Tubes conseillés:**  
Tous tubes thermoplastiques conseillés pour les domaines alimentaires.  
**Tolerances sur les tubes:**  
+/- 0,07 mm jusqu'au Ø 8 mm.

**Domaines d'application:**  
Applications alimentaires et de boissons.

## TECHNISCHE AUSKÜNFTE

**Empfohlene Schläuche:**  
Schläuche tauglich im Nahrungsmittel und Getränkebereich  
**Schlauchtoleranzen:**  
+/- 0,07 mm bis Ø 8 mm.

**Anwendungsbereiche:**  
Anwendungen im Bereich Nahrungsmittel und Getränke.

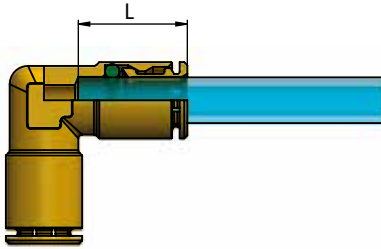

Øe Tubo	L
4	12,8
6	14,3
8	14,3

## ISTRUZIONI DI MONTAGGIO

1. Tagliare il tubo a 90° (servendosi della pinza tagliatubo TCUT) verificando l'assenza di bave interne ed esterne e facendo attenzione che il tubo non si presenti ovalizzato dopo il taglio.
2. Inserire il tubo nel raccordo spingendolo fino in battuta.

## Estrazione del tubo

Esercitare una leggera pressione sull'anello estrattore, estraendo contemporaneamente il tubo dal corpo del raccordo.

## ASSEMBLY INSTRUCTIONS

1. Cut the tube square (by means of a hose cutter i.e. our TCUT) making sure that no burrs are left and that the tube is not oval.
2. Insert the tube into the fitting until it bottoms.

## Tube release

While pressing on the release ring, pull out the tube from the fitting.

## INSTRUCTIONS DE MONTAGE

1. Sectionner le tube à 90° par notre coupe tube TCUT en prenant soin de ne pas créer des bavures et de ne pas ovaliser le tube.
2. Pousser le tube jusqu'au fond du raccord.

## Débranchement du tube

Appuyer sur le poussoir en métal et tirer simultanément sur le tube.

## MONTAGEANWEISUNGEN

1. Schlauch mittels unserer Schlauchschere (TCUT) 90° abscheiden und entgraten.
2. Darauf achten, daß der Schlauch danach nicht oval gequetscht ist und dann ihn in zum Verschraubungsanschlag einstecken.

## Schlauchlösen

Auf den Druckring drücken und gleichzeitig den Schlauch rausziehen.

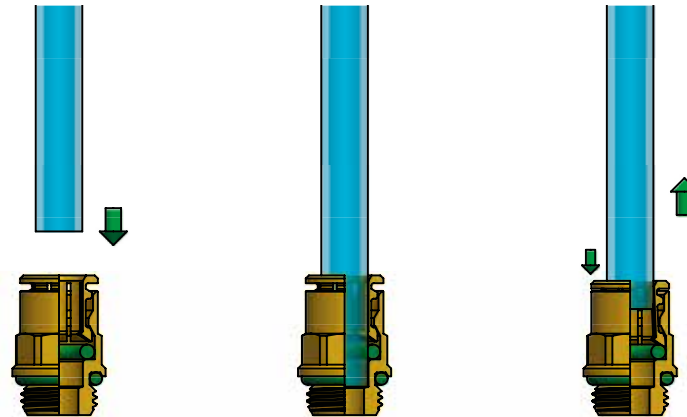

Effettuato il collegamento, assicurarsi che il tubo inserito nel raccordo non sia sottoposto ad alcuna forza di trazione; è necessario inoltre rispettare durante il collegamento del tubo il raggio minimo di curvatura consigliato così come riportato nella sezione tubi di questo catalogo tecnico (vedi pag. 337)

Al fine di evitare lo sgancio involontario del tubo nessun oggetto deve venire a contatto con l'anello estrattore del raccordo evitando così l'esercizio di qualsiasi forza indesiderata, anche solo laterale, che potrebbe causare la pressione dell'anello estrattore e conseguente rilascio del tubo.

Per il serraggio delle parti filettate del raccordo si raccomanda di attenersi alle coppie consigliate riportate a pag.6



Once the tubing is connected to the fitting, make sure that the tubing is not subject to any tensile strength and that the min. recommended bending radius stated in the tubing section of this catalogue is complied with (see page 337). To prevent any accidental tube release, no components have to come in touch with the release ring and exercise any unwanted pressure on the same. Indeed however lateral, any load on the release ring may cause the tube disconnection. To tighten threads, please check out our tightening torque chart illustrated at page 6.



Une fois effectué le branchement, s'assurer que le tube inséré dans le raccord n'est soumis à aucune force de traction. Egalement, il est nécessaire de respecter, lors du branchement du tube, le rayon minimum de courbure conseillé dans la section tubes de ce catalogue technique (voir la page 337). Afin d'éviter le décrochage involontaire du tube, aucun objet ne doit entrer en contact avec la bague d'extraction du raccord, empêchant ainsi l'exercice de toute force indésirable, ne serait-ce que latérale, qui pourrait provoquer la pression de la bague d'extraction et donc le relâchement du tube. Pour le serrage des parties filettées du raccord, il est recommandé de s'en tenir aux couples de serrage conseillés et reportés à la page 6.



Nach der Schlauchverbindung, sicherstellen, dass der in die Verschraubung eingeführte Schlauch keinen Zugbelastungen ausgesetzt ist; beim Anschluss des Schlauchs muss der empfohlene Mindestbiegeradius eingehalten werden, gemäß den in diesem technischen Katalog im Schlauchabschnitt, angegebenen Hinweisen (siehe Seite 337).

Um das versehentliche Lösen des Schlauchs zu verhindern, darf kein Gegenstand den Lösering der Verschraubung berühren. Keine unerwünschte Kraft darf auch nicht seitlich einwirken und kein Druck soll auf den Lösering ausgeübt werden, denn dies das Schlauchlösen verursachen könnte.

Zum Festziehen der Gewinde sich an den, auf Seite 6, empfohlenen Drehmomente einhalten.

## MF 12

Diritto maschio cilindrico

Parallel Straight, male

Union simple mâle cylindrique

Gerade Einschraubverschraubung, zylindrisch

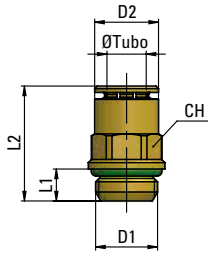

Tipo	Øe Tubo	D1	D2	L1	L2	CH	g $\Delta$
12 04 M5	4	M5x0,8	8	4	18,5	8	3,8
12 04 18	4	G1/8	8	5	17	8	5,6
12 06 M5	6	M5x0,8	10	4	20,5	10	5,5
12 06 18	6	G1/8	10	5	18	10	5,7
12 06 14	6	G1/4	10	6,5	18,5	10	9,4
12 08 18	8	G1/8	12	5	21,5	12	8,5
12 08 14	8	G1/4	12	6,5	19	12	9,2

## MF 13

Diritto femmina

Female Straight

Union simple femelle

Gerade Aufschraubverschraubung

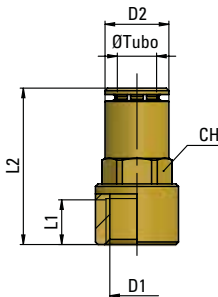

Tipo	Øe Tubo	D1	D2	L1	L2	CH	g $\Delta$
13 04 18	4	G1/8	8	7,5	23,5	8	10
13 06 18	6	G1/8	10	7,5	24,5	10	10,9
13 06 14	6	G1/4	10	11	27,5	10	15,2
13 08 14	8	G1/4	12	11	28	12	16,9

## MF 16

Gomito maschio cilindrico girevole

Parallel Swivelling Elbow Fitting, male

Raccord à coude tournant, mâle cylindrique

Schwenkbare Winkelverschraubung, zylindrisch

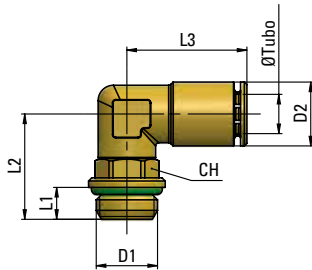

Tipo	Øe Tubo	D1	D2	L1	L2	L3	CH	g $\Delta$
16 04 M5	4	M5x0,8	8	4	14,5	18	9	10,3
16 04 18	4	G1/8	8	5	6,5	18	9	11,5
16 06 M5	6	M5x0,8	10	4	14,5	18,5	9	10,7
16 06 18	6	G1/8	10	5	16,5	18,5	9	11,9
16 06 14	6	G1/4	10	6,5	18	18,5	9	14,6
16 08 18	8	G1/8	12	5	18	20,5	12	17
16 08 14	8	G1/4	12	6,5	20,5	20,5	12	19,3

## MF 21

T Centrale maschio cilindrico girevole

Swivelling Tee fitting, parallel

Raccord à Té tournant, mâle cylindrique

T-Verschraubung, schwenkbar und zylindrisch

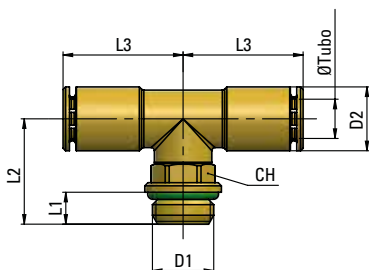

Tipo	Øe Tubo	D1	D2	L1	L2	L3	CH	g $\Delta$
21 04 18	4	G1/8	8	5	16,5	18	9	14,5
21 06 18	6	G1/8	10	5	16,5	18,5	9	15,5
21 06 14	6	G1/4	10	6,5	18	18,5	9	18,2
21 08 18	8	G1/8	12	5	18	20,5	12	22,4
21 08 14	8	G1/4	12	6,5	20,5	20,5	12	24,6

## MF 24

T Laterale maschio cilindrico  
girevole

Lateral Swivelling Tee fitting,  
parallel

Raccord à Té latéral cylindrique,  
tournant

T-Schwenkverschraubung,  
zylindrisch

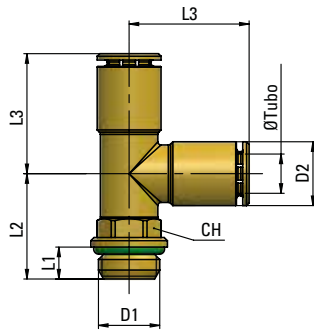

Tipo	Øe Tubo	D1	D2	L1	L2	L3	CH	g $\Delta$
24 04 18	4	G1/8	8	5	16,5	18	9	14,5
24 06 18	6	G1/8	10	5	16,5	18,5	9	15,4
24 06 14	6	G1/4	10	6,5	18	18,5	9	18,1
24 08 18	8	G1/8	12	5	18	20,5	12	22,3
24 08 14	8	G1/4	12	6,5	20,5	20,5	12	24,5

## MF 26

Giunzione Intermedia

Union

Union simple égale

Gerade Verbindung

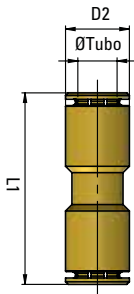

Tipo	Øe Tubo	D2	L1	g $\Delta$
26 04 04	4	8	27	5,1
26 06 06	6	10	30	7,3
26 08 08	8	12	30	9,5

## MF 28

Gomito Intermedio

Union Elbow

Raccord à Coude

Winkerverschraubung

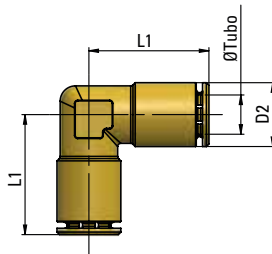

Tipo	Øe Tubo	D2	L1	g $\Delta$
28 04 04	4	8	18	11
28 06 06	6	10	18,5	11,6
28 08 08	8	12	20,5	16,3

## MF 29

T Intermedio

Union Tee

T égal

T-Verschraubung

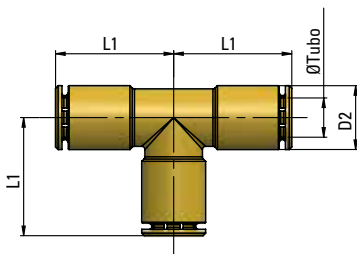

Tipo	Øe Tubo	D2	L1	g $\Delta$
29 04 04	4	8	18	14
29 06 06	6	10	18,5	14,6
29 08 08	8	12	20,5	18,3

**MF 93**

Valvola non ritorno

Chek valve

Clapet anti-retour

Rückschlagventil

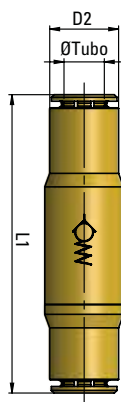

Tipo	Øe Tubo	D2	L1	g
<b>93 04 04</b>	<b>4</b>	8	40	10,7
<b>93 06 06</b>	<b>6</b>	10	45,5	21,4
<b>93 08 08</b>	<b>8</b>	12	45,5	21,4

**MF 94**

Regolatore di flusso in linea

In-Line Flow Control

Réducteur de débit en ligne

Drosselrückschlagventil

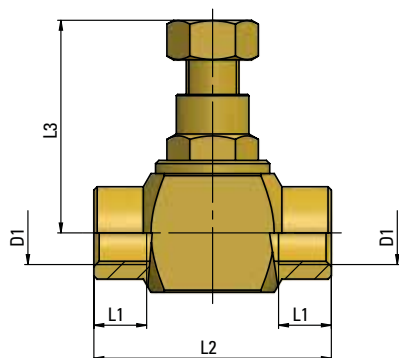

Tipo	D1	L1	L2	L3 max	g
<b>94 18 18</b>	<b>G1/8</b>	8	36	32,5	76,1
<b>94 14 14</b>	<b>G1/4</b>	9	41	32,5	85,8