

FLOW DIVIDERS "XV-3 serie"

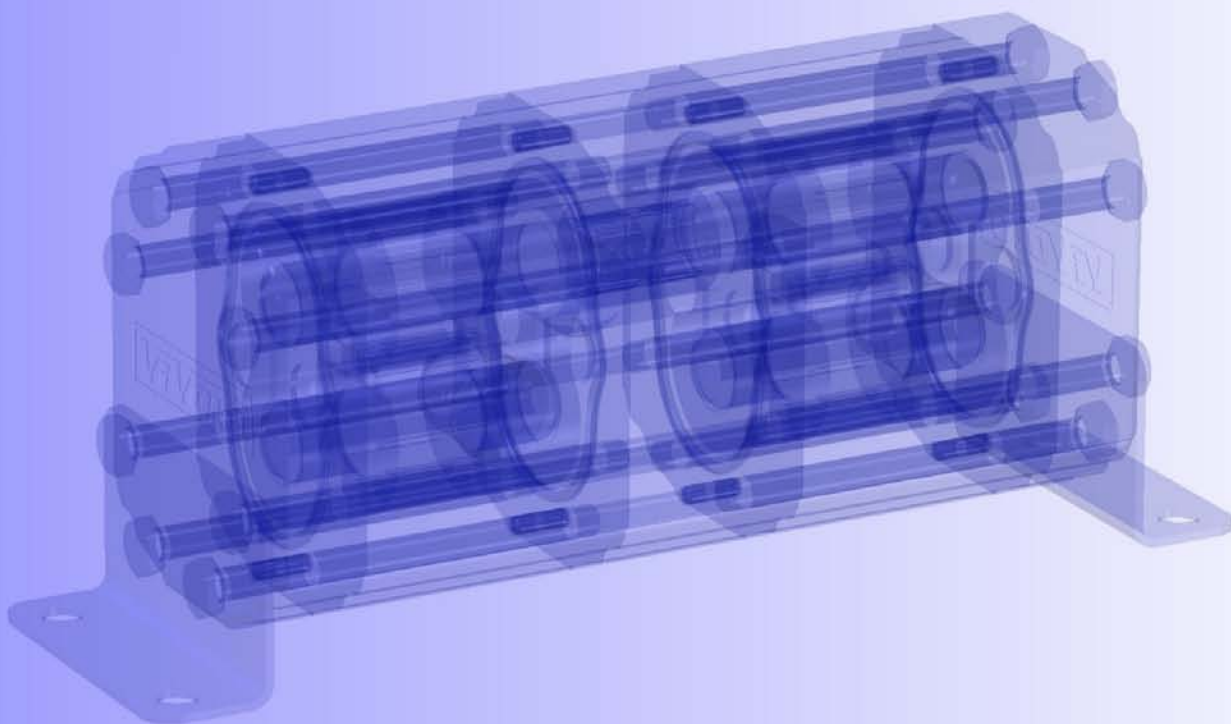

ENGLISH

VERS:07-04-2010



XV-D FLOW DIVIDER

This is the flow divider standard version, it simply divide the incoming flow without allowing the phase correction

XV-G FLOW DIVIDER + MOTOR

The XV-G typology is the motorized version of the XV-D divider. It has a motor conneted to the flow divider elements. This solution is important when the incoming and/or outgoing pressure is below the minimum pressure required to start. Giving flow to the motor, help the flow divider rotation start. Typical use: plants with single effects hydraulic jack.

The flow division error is lower than $\pm 1.5\%$ with a pressure difference between one element and another until 30 Bars. For bigger differences we can approximate an error increase of 1 % for each 10 additional bars.

A flow divider is made up of two or more modular elements (sections) with gears mechanically linked by an internal shaft that causes them to turn at the same speed.

Unlike multiple pumps, in which the input power is mechanical (shaft connected to a motor), in a flow divider the input power is of a fluid-mechanical nature, i.e. a flow of oil under pressure parallelly supplies the modular elements, which are in turn connected to the hydraulic circuits serving the users.

The portion of flow utilized by each element is solely determined by its nominal flow rate. Therefore, unlike standard static dividers with variable ports, the flow dividers do not cause dissipation and are also much more precise.

The use of flow dividers in a system reduces the number of pumps necessary as well as the associated individual mechanical power takeoffs and complex mechanical couplers (with greater losses).

Leaving aside small losses for the time being, at any given moment the total input power is equal to the sum of the powers supplied by all elements making up the flow divider.

Therefore, if in an interval of time the power required by a hydraulic circuit is equal to zero (inactive drained circuit), the power supplied by the element feeding that circuit becomes available for the other elements, which may use it in their own circuits, also operating at higher pressures than the intake pressure.

Most frequent applications of flow dividers

Supply of two or more independent hydraulic circuits by means of a single pump, with an overall flow rate equal to the sum of the flow rates.

Examples of this kind of application:

- lifting platforms and bridges;
- hydraulic bending presses and shearing machines;
- hoisting of freight containers;
- lubrication systems;
- hydraulic opening / closing of gates;
- automatic hydraulically-driven machines;
- actuation of formwork for construction;
- wood processing machinery;
- conveyance of trolleys driven by hydraulic cylinders or motors;
- equipment for the food industry;
- military installations.

Pressure amplifiers.

When in a hydraulic system one user requires a much higher operating or peak pressure than all the others, it is more convenient to supply it by means of a flow divider than to upgrade the whole system to work with higher pressure.

With a two-element flow divider flow may be discharged from the outlet of one element so that the pressure in the other will become much higher than that of the pump supplying the system.

Examples of this kind of application:

- presses with rapid approach
- machine tools

Constructive features

FLOW DIVIDER BODY FLANGE AND COVER	Extruded alloy Serie 7000, heat treated and anodised	$R_p=345 \text{ N/mm}^2$ (Yield Strength) $R_m=382 \text{ N/mm}^2$ (Breaking Strength)
GEAR BUSH BEARINGS	Special Heat Treated tin alloy with excellent mechanical features and high anti-friction capacity. Self-lubricating bushes DU	$R_p=350 \text{ N/mm}^2$ (Yield Strength) $R_m=390 \text{ N/mm}^2$ (Breaking Strength)
GEARS	Steel UNI 7846	$R_s=980 \text{ N/mm}^2$ (Yield Strength) $R_m=1270\div 1570 \text{ N/mm}^2$ (Breaking Strength)
GASKET	A 727 Acrolonitrile Standard F 975 Viton FKM	90 Shore, thermal resistance 120°C 80 Shore, thermal resistance 200°C

Code:

9D NN CC

9D	Flow Divider Typology
NN	Number of elements
CC	Displacement Code

Example: Flow divider with two elements (same displacement):
XV-3D / 38 x 2

9D 02 78

Example: Flow Divider with 4 elements with different displacement (max 7):
XV-3D / 21+51+51+70

9D 04 70 81 81 86

NOTE: to define codes for flow dividers with more than 7 different displacement, please contact our sales department.

Table: 1

Displacem. Cm ³ /rev	CC Code	Max Pressure bar	One element flow rate l/min		
			MIN	RECOMMENDED	MAX
15	66	300	18	27	37,5
18	68	300	21,5	32,5	45
21	70	280	25	38	52,5
27	72	250	32,5	48	67,5
32	74	250	38	57	80
38	78	250	41	60	91
43	79	250	43	64,5	99
47	80	230	47	70,5	108
51	81	230	51	76,5	117
54	82	230	54	81	124
61	83	230	56	82	126
64	85	210	57	83	128
70	86	200	63	91	140
74	87	180	66,5	96	148
90	89	150	81	117	180

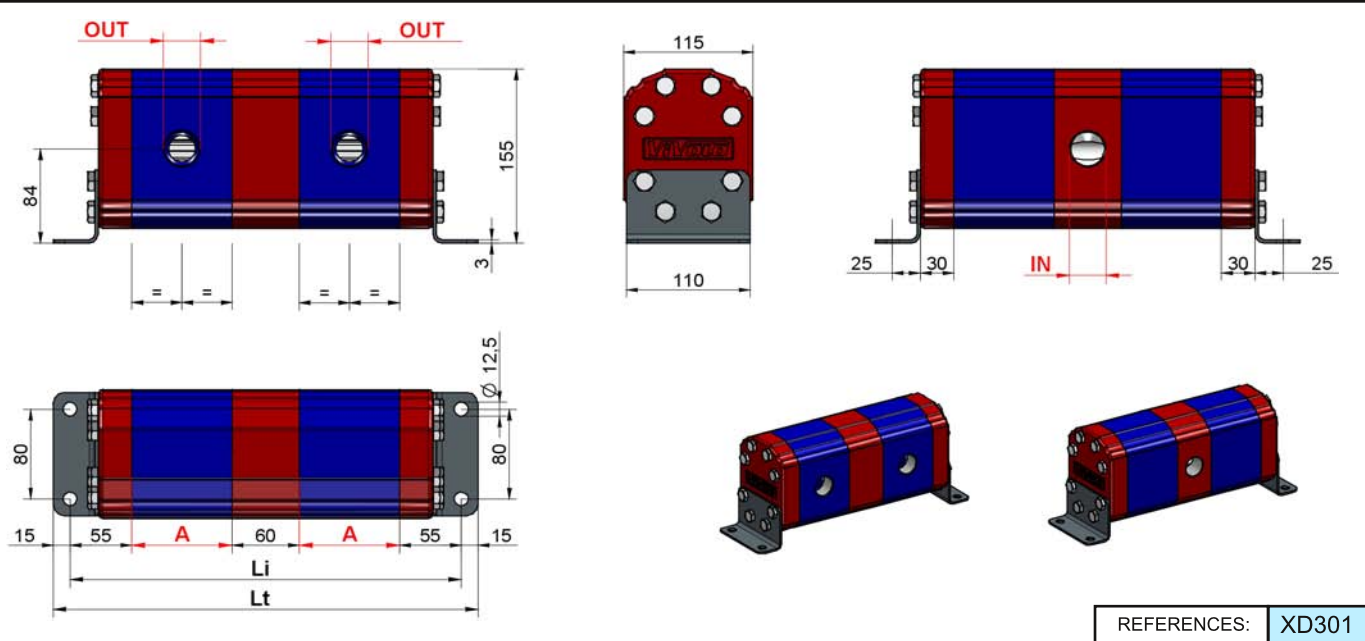

Table: 2

Li = Distance between fixing hole centres (single displacement flow divider)

Cm ³ /rev	A	IN	OUT	Number of elements															
				2	3	4	5	6	7	8	9	10	11	12	13	14	15	16	
15	66	1" BSP	1/2 BSP	302	428	554	680	806	932	1058	1184	1310	1436	1562	1688	1814	1940	2066	
18	68	1" BSP	1/2 BSP	306	434	562	690	818	946	1074	1202	1330	1458	1586	1714	1842	1970	2098	
21	71	1" BSP	1/2 BSP	312	443	574	705	836	967	1098	1229	1360	1491	1622	1753	1884	2015	2146	
27	75	1" BSP	3/4 BSP	320	455	590	725	860	995	1130	1265	1400	1535	1670	1805	1940	2075	2210	
32	80	1" BSP	3/4 BSP	330	470	610	750	890	1030	1170	1310	1450	1590	1730	1870	2010	2150	2290	
38	85	1" BSP	3/4 BSP	340	485	630	775	920	1065	1210	1355	1500	1645	1790	1935	2080	2225	2370	
43	89	1" BSP	1" BSP	348	497	646	795	944	1093	1242	1391	1540	1689	1838	1987	2136	2285	2434	
47	92	1-1/4 BSP	1" BSP	354	506	658	810	962	1114	1266	1418	1570	1722	1874	2026	2178	2330	2482	
51	95	1-1/4 BSP	1" BSP	360	515	670	825	980	1135	1290	1445	1600	1755	1910	2065	2220	2375	2530	
54	98	1-1/4 BSP	1" BSP	366	524	682	840	998	1156	1314	1472	1630	1788	1946	2104	2262	2420	2578	
61	103	1-1/4 BSP	1" BSP	376	539	702	865	1028	1191	1354	1517	1680	1843	2006	2169	2332	2495	2658	
64	106	1-1/4 BSP	1" BSP	382	548	714	880	1046	1212	1378	1544	1710	1876	2042	2208	2374	2540	2706	
70	111	1-1/4 BSP	1" BSP	392	563	734	905	1076	1247	1418	1589	1760	1931	2102	2273	2444	2615	2786	
74	114	1-1/4 BSP	1" BSP	398	572	746	920	1094	1268	1442	1616	1790	1964	2138	2312	2486	2660	2834	
90	124	1-1/4 BSP	1-1/4 BSP	418	602	786	970	1154	1338	1522	1706	1890	2074	2258	2442	2626	2810	2994	

Table: 3 in this table the number of inlets in function of the number of elements are indicated.

Number of elements	2	3	4	5	6	7	8	9	10	11	12	13	14	15	16
"IN" Number of inlets	1	2	2	3	3	4	4	5	5	6	6	7	7	8	8

INTERNAL DRAIN

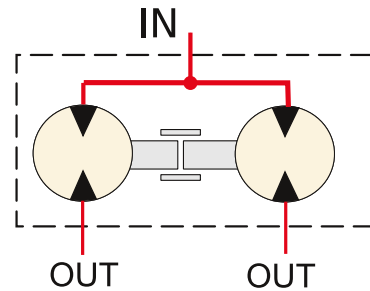
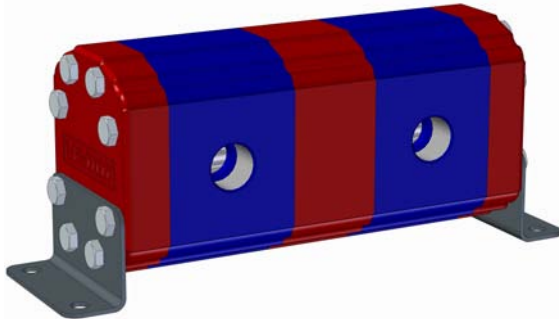

In **table 1** the functioning range of single flow divider elements is indicated.

The higher is the feeding capacity (q), the higher is the precision of flow division, but in opposition there are losses of loading and higher noise. Therefore we suggest to feed the elements with capacities equal or a few superior to the ones indicated in the column "**RECOMMENDED**".

It's important remember to verify the capacities even in phase of flow reunion.

The pressures indicated are to be considered as maximum of functioning, the flow divider is able to bear peaks of pressure 20% superior.

How to calculate the "Li" and "Lt" measures of flow dividers:

From **table 2** it is possible to obtain the "Li" measure for flow dividers up to 16 elements with equal displacements; for flow dividers with different elements or with more than 16 elements the "Li" and "Lt" measure have to be calculated by the following formula:

$$Li = [(n-1) \times 60] + 110 + (A1 + A2 + A3 + \dots)$$

$$110 = 55 + 55$$

n = Number of elements of flow divider

A1... An = heights of elements of flow divider

$$Lt = Li + 30$$

$$30 = 15 + 15$$

EXAMPLE: To obtain the measures Li and Lt of a flow divider with three elements (n=3), **XV-3D 27 + 38 + 54**

Distance between fixing hole centres $Li = [(3-1) \times 60] + 110 + 75 + 85 + 98 = 488 \text{ mm}$

Total Length $Lt = 488 + 30 = 518 \text{ mm}$

In **table 3** the number of inlets in fuction of the number of elements are indicated.

For flow dividers with many inlets, as they are all communicating it is even possible to use only one of them, by plugging the other ones. We suggest to use at least one **1" BSP** inlet every **200 l/min** capacity and at least one **1-1/4" BSP** inlet every **360 l/min** capacity

To obtain errors of division inferior to 3% there must be no difference of pressure between the elements superior to 30 bar. To obtain high precisions the respect of the following parametres is also important:

- Enviroment temperature: -10°C ÷ +60°C Oil temperature: +30°C ÷ +60°C
- Hydraulic oil based on hlp, hv (din 51524) minerals Oil Viscosity 20 ÷ 40 cSt
- Oil filtering 10 ÷ 25 µ



VIVOIL OLEODINAMICA VIVOLO s.r.l Società a Socio Unico
Via Leone Ginzburg 2-4 - 40054 Cento di Budrio (BO) - ITALY
P.I. e C.F. 03542620376 C.C.I.A.A. 299009 - Iscr. Trib. - BO 43434
TEL. +39 051.803689 Fax +39 051.800061 www.vivoil.com info@vivoil.com

