

# KRACHT

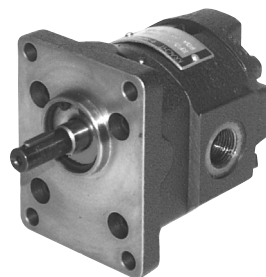

Gear Pumps

**KF 0**

**KF 0** with magnetic coupling

## Contents

---

|   |    |
|---|----|
| Contents .....                                | 2  |
| Description KF 0 .....                        | 3  |
| Characteristics .....                         | 4  |
| Working characteristics .....                 | 4  |
| Available pump types .....                    | 4  |
| Technical data .....                          | 5  |
| Discharge flow / Input power .....            | 5  |
| Type key KF 0 .....                           | 6  |
| Construction .....                            | 7  |
| Dimensions special number 100 .....           | 8  |
| Dimensions special number 107 .....           | 9  |
| Dimensions special number 212 .....           | 10 |
| Accessory couplings .....                     | 11 |
| Accessory bell housing .....                  | 12 |
| Description KF 0 with magnetic coupling ..... | 13 |
| Characteristics .....                         | 13 |
| Working characteristics .....                 | 13 |
| Magnetic coupling materials .....             | 14 |
| Magnetic coupling torques .....               | 14 |
| Selection assistance .....                    | 14 |
| Type key KF 0 with magnetic coupling .....    | 15 |
| Product portfolio .....                       | 16 |

## Description

---

### **KF 0 – a pump for process engineering.**

In numerous technical processes dosing liquids is the focus of the task. PUR components, softeners, resins, lacquers, paints are just some of the most important liquids with a broad application range.

The accuracy, evenness and reproducibility with which these products can be processed are also decisive for the quality of the final product.

The gear pump size KF 0 is especially suitable for these applications.

The KF 0 is an external gear pump with flow rates of  $0.5 \text{ cm}^3/\text{r}$  to  $4 \text{ cm}^3/\text{r}$ .

The grading of the total of 8 nominal sizes makes it easier to set the desired dosing ratios.

The fine gearing with a high number of teeth guarantees a low-pulsation volume flow.

All gear parts and the bearing bushes are protected even in the standard design by a special coating against wear and corrosion, so that even filled media up to a specific grain size and hardness of the filled material can be conveyed. Because of the backlash dimensioning in combination with precise production the KF 0 has very good volumetric efficiency over a wide pressure range.

Various types of seals, such as rotary shaft seals and double rotary shaft seals can be selected depending on the task, whereby the latter version enables operations with quench (quench chamber) to prevent the pumping medium from hardening or crystallising.

In combination with a flow meter and the electronics the KF 0 can be extended to a highly precise dosing unit.

## Characteristics

|                       |                                   |     |
|-----------------------|-----------------------------------|-----|
| Fixing type           | flange                            |     |
| Pipe connection       | threaded ports                    |     |
| Direction of rotation | clockwise <b>or</b> anticlockwise |     |
| Mounting position     | arbitrary (see dim. sheets)       |     |
| Weight                | kg                                | 2.2 |

## Working Characteristics

|                                   |  |  |
|-----------------------------------|--|--|
| Displacement (cm <sup>3</sup> /r) | V <sub>g</sub>                           | 0.5 / 0.8 / 1.0 / 1.6 / 2.0 / 2.5 / 3.0 / 4.0                            |
| Working pressure Inlet port       | p <sub>e min</sub><br>p <sub>e max</sub> | -0.4 bar (-0.6 bar short for starting status)<br>2 bar                   |
| Working pressure Outlet port      | p <sub>n min</sub>                       | 120 bar<br>(depending on the pumping medium, viscosity and displacement) |
| Speed                             | n  | 3000 1/min (dependent by viscosity)                                      |
| Viscosity                         | v <sub>min</sub><br>v <sub>max</sub>     | = 10 mm <sup>2</sup> /s<br>= 20 000 mm <sup>2</sup> /s                   |
| Media temperature                 | ϑ <sub>m max</sub>                       | = 90 °C NBR<br>= 150 °C FKM<br>= 200 °C PTFE<br>(rotary shaft seal)      |
| Ambient temperature               | ϑ <sub>u min</sub><br>ϑ <sub>u max</sub> | = -20 °C<br>= 60 °C  |

## Available Pump Types

| Pump type          | Available sizes                                     | Housing material  | Bearing      | Bearing material  | Gear  | Shaft seal                                 | Non-ferrous metals |
|--------------------|---|---|--------------|---|---|--|--------------------|
| <b>KF0/.../100</b> | 0.5 / 0.8 / 1.0 /<br>1.6 / 2.0 / 2.5 /<br>3.0 / 4.0 | EN-GJL-250  | Bearing bush | Steel ETG 100, chemically nickel plated with SiC inclusions | Steel 1.7139 chemically nickel plated with SiC inclusions | Rotary shaft seal<br>NBR, FKM, PTFE        | yes                |
| <b>KF0/.../107</b> | 0.5 / 0.8 / 1.0 /<br>1.6 / 2.0 / 2.5 /<br>3.0 / 4.0 | EN-GJL-250  | Bearing bush | Steel ETG 100, chemically nickel plated with SiC inclusions | Steel 1.7139 chemically nickel plated with SiC inclusions | Double rotary shaft seal<br>NBR, FKM, PTFE | yes                |
| <b>KF0/.../212</b> | 0.5 / 1.0 /<br>2.0 / 4.0                            | EN-GJS-600<br>nitro carbonized;<br>Flange cover<br>EN-GJS-600<br>tenifer nitrided | Bearing bush | Steel ETG 100, chemically nickel plated with SiC inclusions | Tool steel, nitrided                                      | Double rotary shaft seal<br>FKM, FEP       | yes                |

**Technical Data** max. permissible working pressure in dependence on viscosity

| Nominal size | Permissible working pressure in bar for viscosity |                       |                        |                          |
|--------------|---|-----------------------|------------------------|--------------------------|
|              | 10 mm <sup>2</sup> /s                             | 30 mm <sup>2</sup> /s | 100 mm <sup>2</sup> /s | > 500 mm <sup>2</sup> /s |
| 0.5          | 10  | 30                    | 50                     | 60                       |
| 0.8          | 15  | 40                    | 60                     | 70                       |
| 1.0          | 15  | 40                    | 60                     | 70                       |
| 1.6          | 20  | 60                    | 80                     | 100                      |
| 2.0          | 20  | 60                    | 80                     | 100                      |
| 2.5          | 30  | 60                    | 100                    | 120                      |
| 3.0          | 30  | 60                    | 100                    | 120                      |
| 4.0          | 40  | 80                    | 120                    | 120                      |

The values are valid for the speed range n = 1000 ... 3000 1/min.  
Then max. working pressures must be reduced for speeds < 1000 1/min

**Discharge Flow / Input Power**

| Speed n = 1450 1/min / Viscosity = 34 mm <sup>2</sup> /s |                   |     |     |     |     |     |     |     |              |                   |      |      |      |      |      |     |     |                     |
|--|-------------------|-----|-----|-----|-----|-----|-----|-----|--------------|-------------------|------|------|------|------|------|-----|-----|---------------------|
|  | Pressure p in bar |     |     |     |     |     |     |     | Nominal size | Pressure p in bar |      |      |      |      |      |     |     |                     |
|  | 5                 | 10  | 20  | 40  | 60  | 80  | 100 | 120 |              | 5                 | 10   | 20   | 40   | 60   | 80   | 100 | 120 |                     |
| Discharge flow Q in l/min                                | 0.7               | 0.6 | 0.5 | -   | -   | -   | -   | -   | 0.5          | 0.06              | 0.07 | 0.09 | -    | -    | -    | -   | -   | Input power P in KW |
|  | 1.1               | 1.1 | 1.0 | 0.8 | -   | -   | -   | -   | 0.8          | 0.06              | 0.08 | 0.11 | 0.17 | -    | -    | -   | -   |                     |
|  | 1.4               | 1.3 | 1.3 | 1.1 | -   | -   | -   | -   | 1.0          | 0.07              | 0.08 | 0.12 | 0.19 | -    | -    | -   | -   |                     |
|  | 2.2               | 2.2 | 2.0 | 1.8 | 1.5 | -   | -   | -   | 1.6          | 0.08              | 0.12 | 0.18 | 0.31 | 0.45 | -    | -   | -   |                     |
|  | 2.8               | 2.7 | 2.6 | 2.3 | 2.0 | -   | -   | -   | 2.0          | 0.09              | 0.13 | 0.20 | 0.35 | 0.50 | -    | -   | -   |                     |
|  | 3.5               | 3.4 | 3.3 | 3.0 | 2.7 | -   | -   | -   | 2.5          | 0.09              | 0.14 | 0.22 | 0.39 | 0.55 | -    | -   | -   |                     |
|  | 4.2               | 4.2 | 4.0 | 3.7 | 3.5 | -   | -   | -   | 3.0          | 0.10              | 0.15 | 0.24 | 0.42 | 0.60 | -    | -   | -   |                     |
|  | 5.6               | 5.5 | 5.4 | 5.0 | 4.7 | 4.3 | -   | -   | 4.0          | 0.12              | 0.17 | 0.29 | 0.53 | 0.76 | 0.99 | -   | -   |                     |

| Speed n = 1450 1/min / Viscosity = 120 mm <sup>2</sup> /s |                   |     |     |     |     |     |     |     |              |                   |      |      |      |      |      |      |      |                     |
|---|-------------------|-----|-----|-----|-----|-----|-----|-----|--------------|-------------------|------|------|------|------|------|------|------|---------------------|
|   | Pressure p in bar |     |     |     |     |     |     |     | Nominal size | Pressure p in bar |      |      |      |      |      |      |      |                     |
|   | 5                 | 10  | 20  | 40  | 60  | 80  | 100 | 120 |              | 5                 | 10   | 20   | 40   | 60   | 80   | 100  | 120  |                     |
| Discharge flow Q in l/min                                 | 0.7               | 0.7 | 0.6 | 0.5 | -   | -   | -   | -   | 0.5          | 0.06              | 0.07 | 0.09 | 0.12 | -    | -    | -    | -    | Input power P in KW |
|   | 1.1               | 1.1 | 1.1 | 1.0 | 0.9 | -   | -   | -   | 0.8          | 0.06              | 0.08 | 0.10 | 0.16 | 0.21 | -    | -    | -    |                     |
|   | 1.4               | 1.4 | 1.4 | 1.3 | 1.2 | -   | -   | -   | 1.0          | 0.08              | 0.09 | 0.12 | 0.17 | 0.23 | -    | -    | -    |                     |
|   | 2.3               | 2.2 | 2.2 | 2.1 | 2.0 | 1.8 | -   | -   | 1.6          | 0.08              | 0.11 | 0.16 | 0.27 | 0.38 | 0.50 | -    | -    |                     |
|   | 2.8               | 2.8 | 2.8 | 2.7 | 2.6 | 2.5 | -   | -   | 2.0          | 0.09              | 0.12 | 0.20 | 0.34 | 0.49 | 0.64 | -    | -    |                     |
|   | 3.5               | 3.5 | 3.4 | 3.3 | 3.2 | 3.0 | 2.9 | -   | 2.5          | 0.09              | 0.14 | 0.22 | 0.38 | 0.55 | 0.71 | 0.88 | -    |                     |
|   | 4.2               | 4.2 | 4.2 | 4.1 | 3.9 | 3.8 | 3.7 | -   | 3.0          | 0.10              | 0.15 | 0.24 | 0.43 | 0.61 | 0.80 | 0.98 | -    |                     |
|   | 5.7               | 5.6 | 5.6 | 5.5 | 5.3 | 5.2 | 5.0 | 4.9 | 4.0          | 0.12              | 0.17 | 0.29 | 0.53 | 0.76 | 0.99 | 1.23 | 1.46 |                     |

Type Key

Ordering example

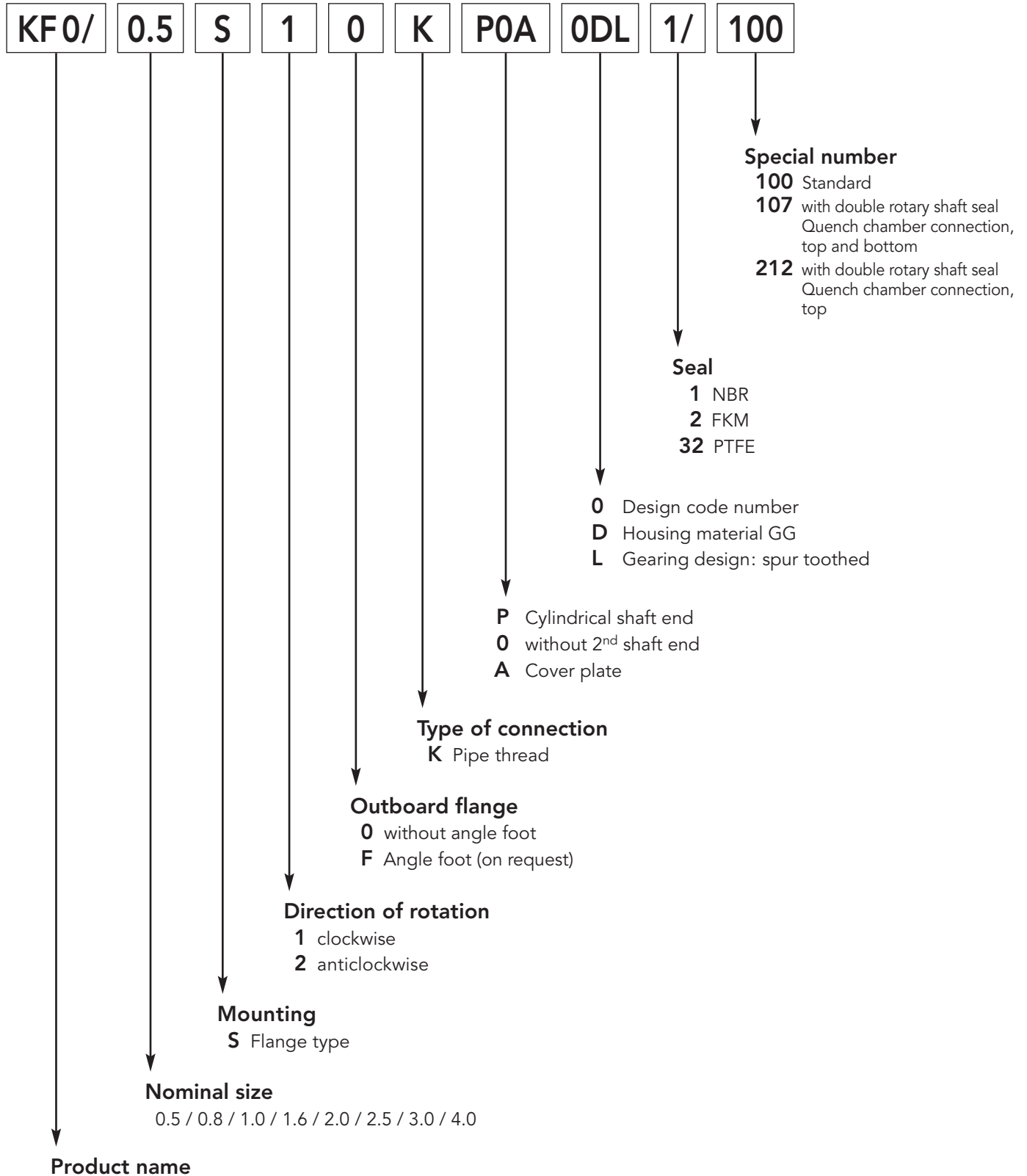

Construction

Flange pump with rotary shaft seal

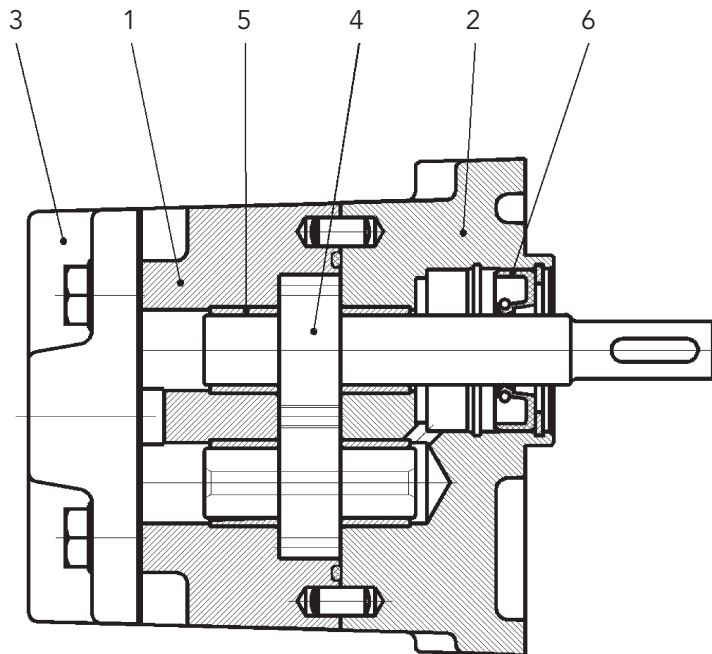

- 1 Housing
- 2 Flange cover
- 3 Cover plate
- 4 Gearing
- 5 Bearing bush
- 6 Rotary shaft seal

Flange pump with double rotary shaft seal and threaded Connection for quench

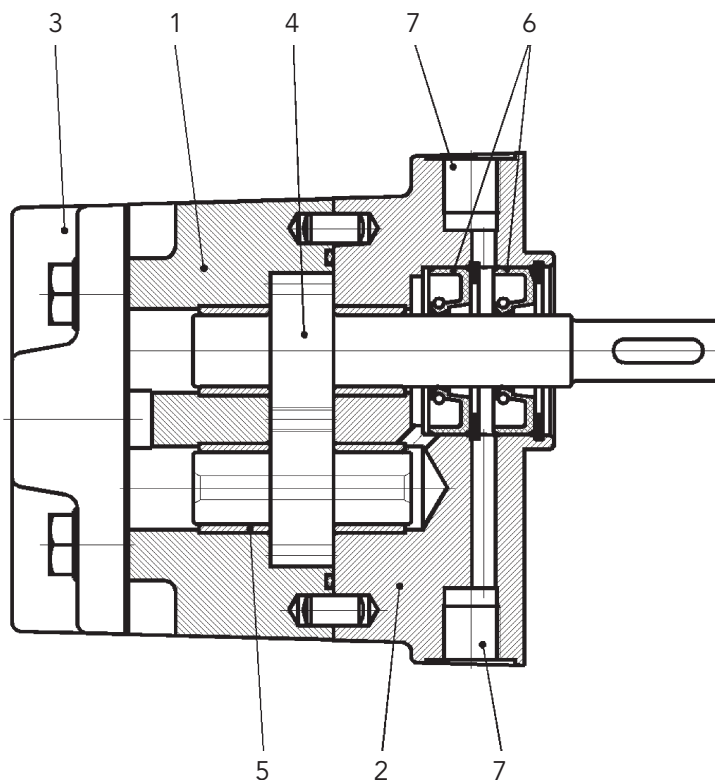

- 1 Housing
- 2 Flange cover
- 3 Cover plate
- 4 Gearing
- 5 Bearing bush
- 6 Double rotary shaft seal
- 7 Connection for quench

## Dimensions Special Number 100 (in mm)

KF 0 / . S . 0K P0A 0DL . / 100

Direction of rotation shown:  
clockwise

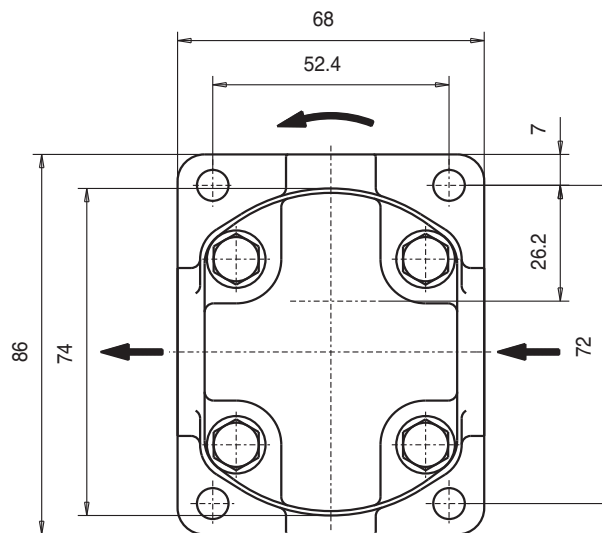
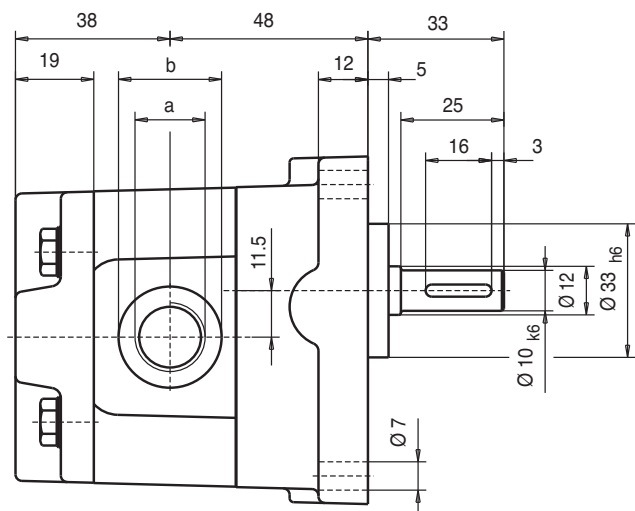

Suction and pressure connection are the same size

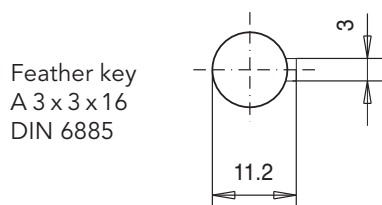

| Vg<br>cm <sup>3</sup> /r | Flow volume / nominal size |     |     |                 |     |     |     |     |
|--------------------------|----------------------------|-----|-----|-----------------|-----|-----|-----|-----|
|                          | 0.5                        | 0.8 | 1.0 | 1.6             | 2.0 | 2.5 | 3.0 | 4.0 |
| a                        | G 3/8 – 13 deep            |     |     | G 1/2 – 15 deep |     |     |     |     |
| b                        | 25                         |     |     | 29              |     |     |     |     |



**Dimensions Special Number 107** (in mm)

**KF 0 / . S . 0K P0A 0DL . / 107**

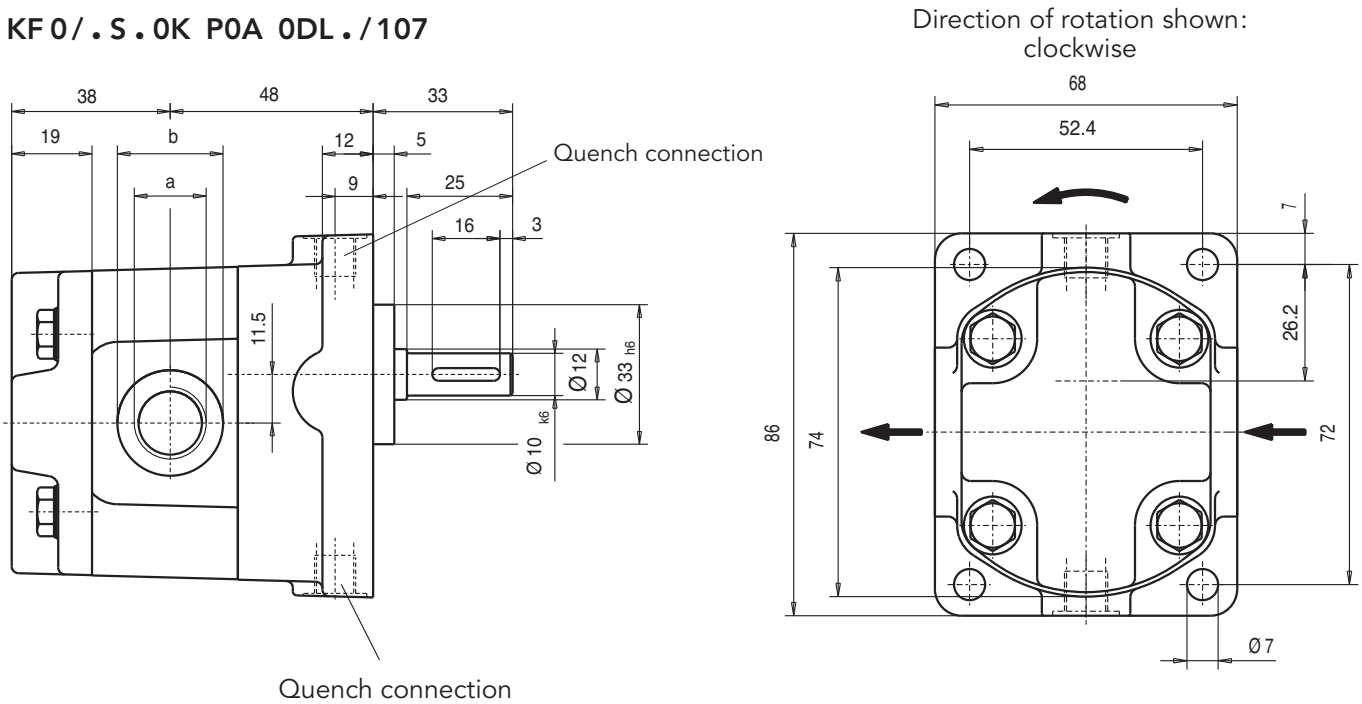

Mounting position: horizontal

Suction and pressure connection are the same size

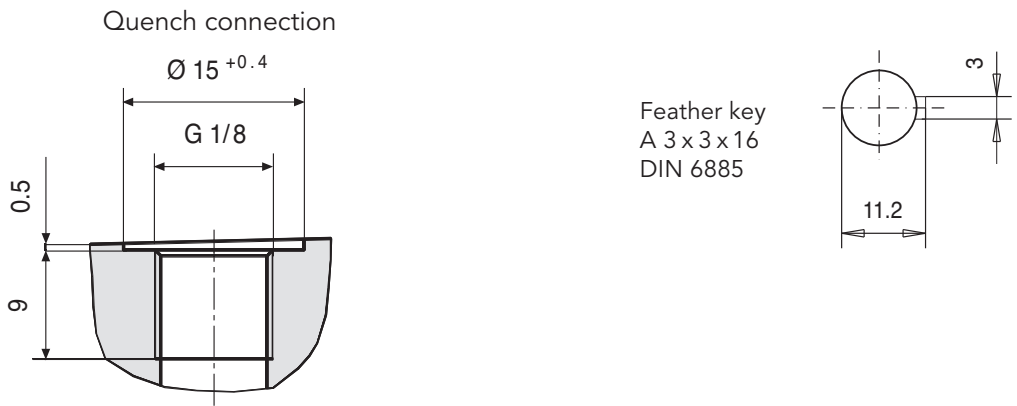

| Vg<br>cm <sup>3</sup> /r | Flow volume / nominal size |     |     |                 |     |     |     |     |
|--------------------------|----------------------------|-----|-----|-----------------|-----|-----|-----|-----|
|                          | 0.5                        | 0.8 | 1.0 | 1.6             | 2.0 | 2.5 | 3.0 | 4.0 |
| a                        | G 3/8 – 13 deep            |     |     | G 1/2 – 15 deep |     |     |     |     |
| b                        | 25                         |     |     | 29              |     |     |     |     |

## Dimensions Special Number 212 (in mm)

KF 0 / . S . 0K P0A 0DL . / 212

Direction of rotation shown:  
clockwise

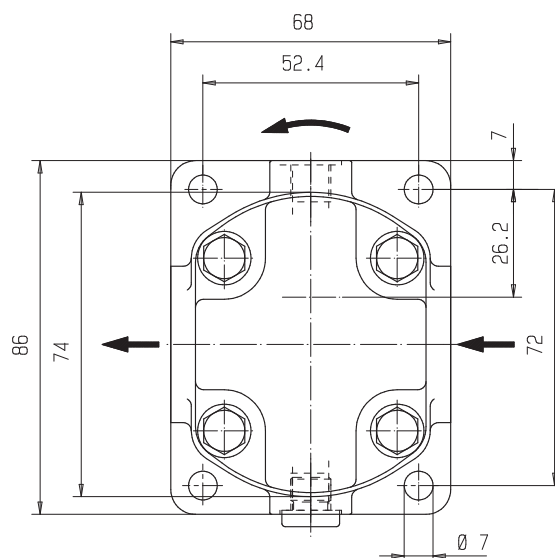
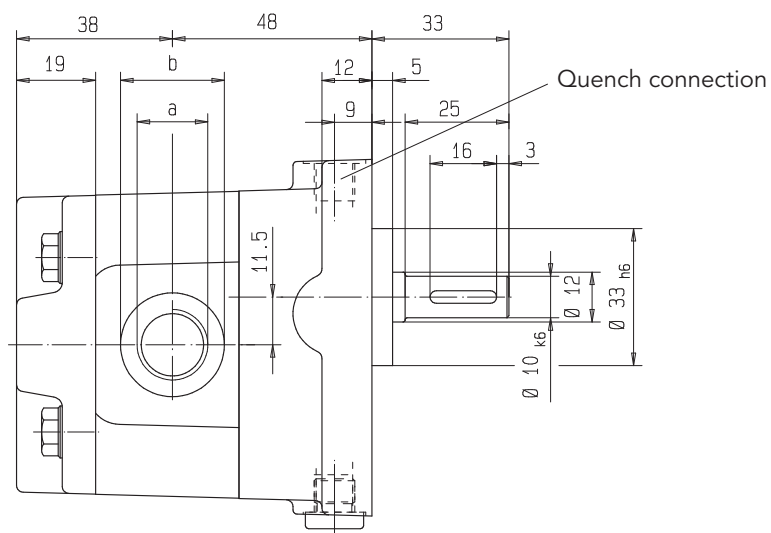

Suction and pressure connection are the same size

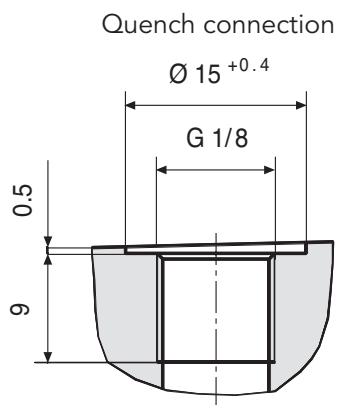

Feather key  
A 3 x 3 x 16  
DIN 6885

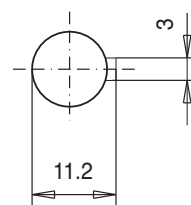

| Vg<br>cm <sup>3</sup> /r | Flow volume / nominal size |     |                 |     |
|--------------------------|----------------------------|-----|-----------------|-----|
|                          | 0.5                        | 1.0 | 2.0             | 4.0 |
| a                        | G 3/8 – 13 deep            |     | G 1/2 – 15 deep |     |
| b                        | 25                         |     | 29              |     |

Accessory Couplings

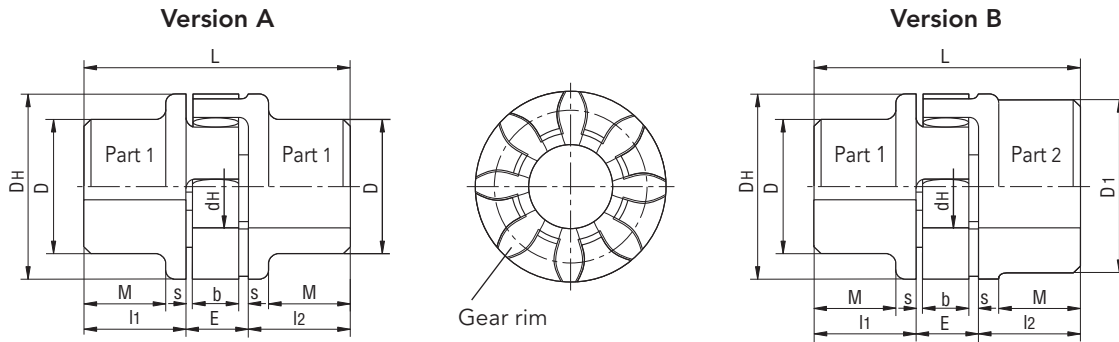

|           | Ordering code             | Coupling size | Hub material (AL) |                                    | Finished bore |    |      |    | Dimensions (in mm) |    |     |    |    |    |    |    |                |    |
|-----------|---------------------------|---------------|-------------------|------------------------------------|---------------|----|------|----|--------------------|----|-----|----|----|----|----|----|----------------|----|
|           |                           |               | Weight kg         | Moment of inertia kgm <sup>2</sup> | min.          |    | max. |    | l1/l2              | E  | s   | b  | L  | M  | DH | D  | D <sub>1</sub> | dh |
| Version A | RA 14-Z 11/...-Z 11/..    | 14            | 0.045             | 0.000006                           | 6             | -  | 16   | -  | 11                 | 13 | 1,5 | 10 | 35 | -  | 30 | 30 | -              | 10 |
|           | RA 19-Z 25/...-Z 25/..    | 19            | 0.117             | 0.000023                           | 6             | -  | 19   | -  | 25                 | 16 | 2   | 12 | 66 | 20 | 41 | 32 | -              | 18 |
| Version B | RA 19/24-Z 25/...-Z 25/.. | 19/24         | 0.129             | 0.000033                           | 6             | 19 | 19   | 24 | 25                 | 16 | 2   | 12 | 66 | 20 | 41 | 32 | 41             | 18 |
|           | RA 24/28-Z 30/...-Z 30/.. | 24/28         | 0.29              | 0.00014                            | 9             | 24 | 22   | 28 | 30                 | 18 | 2   | 14 | 78 | 24 | 56 | 40 | 56             | 27 |

Type Key KF Coupling

Ordering example

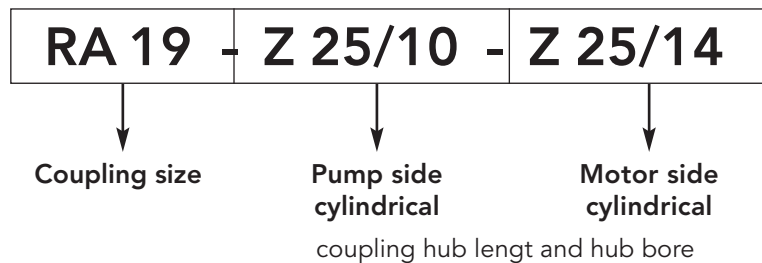

Working temperature:  
 -20°C to +80°C (-4°F to 176°F)  
 (short duration temperature peaks up to 120°C / 248°F are permissible).

Weights and mass moments of inertia refer to max. finish machined bore without slot.  
 Finish-machined bores to ISO Fit H7,  
 parallel key slots in accordance with DIN 6886 Sh.1.

## Accessory Bell Housing

**KF 0** Aluminum bell housing

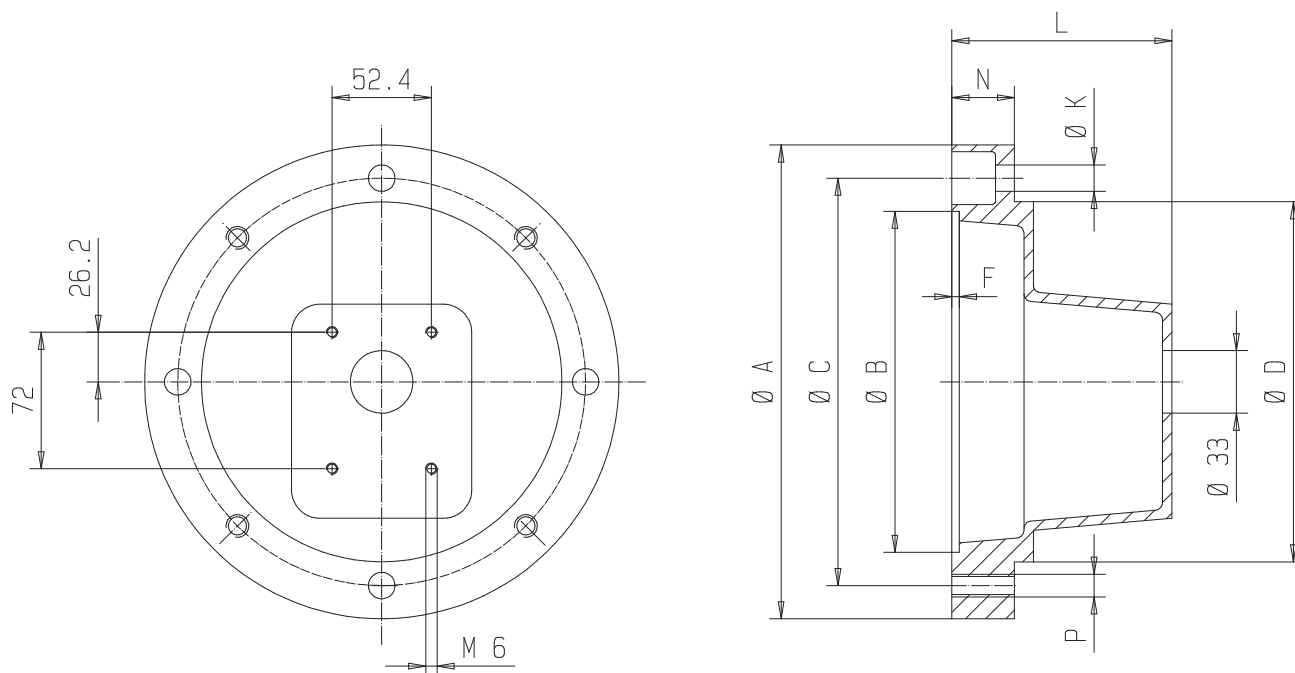

| Motor size               | Bell housing | Coupling              | Dimensions (in mm) |     |     |     |   |    |     |    |     | Weight<br>kg |
|--------------------------|--------------|-----------------------|--------------------|-----|-----|-----|---|----|-----|----|-----|--------------|
|                          |              |                       | A                  | B   | C   | D   | F | K  | L   | N  | P   |              |
| 63                       | Z0/140/70    | RA14-Z11/10-Z11/11    | 140                | 95  | 115 | 95  | 4 | 9  | 70  | 17 | M8  | 0.36         |
| 71 S<br>71               | Z0/160/80    | RA19-Z25/10-Z25/14    | 160                | 110 | 130 | 110 | 4 | 9  | 80  | 13 | M8  | 0.49         |
| 80 S<br>80               | Z0/200/90    | RA19-Z25/10-Z25/19    | 200                | 130 | 165 | 145 | 5 | 11 | 90  | 16 | M10 | 0.6          |
| 90 S<br>90 L             | Z0/200/100   | RA19/24-Z25/10-Z25/24 | 200                | 130 | 165 | 145 | 4 | 11 | 100 | 27 | M10 | 1.345        |
| 100 LS<br>100 L<br>112 M | Z0/250/116   | RA24/28-Z30/10-Z30/28 | 250                | 180 | 215 | 190 | 4 | 14 | 116 | 33 | M12 | 1.4          |

## Description

With various applications conventional seals come up against their limits. Typical applications can be found in PUR plants, refrigerating installations and vacuum plant. It is possible to fit the KF 0 with a magnetic coupling for these applications.

The magnetic coupling serves as a shaft seal and to transmit the torque. The outer rotor of the magnetic coupling is placed on the motor shaft and the inner rotor directly on the pump shaft. The torque is transmitted between the outer and inner rotors through the magnetic forces.

The split case, which seals the pump hermetically, is located between the two rotors.

The magnetic coupling is used if an absolutely tight seal is required between the pump chamber and the atmosphere, e.g. for dosing isocyanate, where contact with the air would lead to an undesired hardening of the medium. It can be used in vacuum operations, e.g. filling brake liquid, and reliably prevents air penetrating into the system.

Non-leak operations are also guaranteed when used in sealed systems with a high admission pressure on the pump suction side.

The magnetic coupling is predestined for dosing hazardous and harmful media.

## Characteristics

|                       |                                   |
|-----------------------|-----------------------------------|
| Fixing typ            | flange                            |
| Pipe connection       | threaded ports                    |
| Direction of rotation | clockwise <b>or</b> anticlockwise |
| Mounting              | arbitrary                         |

## Working Characteristics

|                                   |                    |   |
|-----------------------------------|--------------------|---|
| Displacement (cm <sup>3</sup> /r) | V <sub>g</sub>     | 0.5 / 0.8 / 1.0 / 1.6 / 2.0 / 2.5 / 3.0 / 4.0   |
| Working pressure Inlet port       | Working            | p <sub>e min</sub> -0.4 bar, vacuum facility -0.92 bar<br>p <sub>e max</sub> 16 bar (SS1) |
|                                   | Standstill         | p <sub>e min</sub> -1 bar<br>p <sub>e max</sub> 16 bar (SS1)                              |
| Working pressure Outlet port      | p <sub>n max</sub> | 25 bar (SS1)  |
| Speed                             | n                  | 3000 1/min (affected by viscosity)  |
| Viscosity                         | v <sub>min</sub>   | = 10 mm <sup>2</sup> /s   |
|                                   | v <sub>max</sub>   | = 20 000 mm <sup>2</sup> /s   |
| Media temperature                 | ϑ <sub>min</sub>   | = -10 °C  |
|                                   | ϑ <sub>max</sub>   | = 150 °C FKM, magnet material SmCo  |
| Ambient temperature               | ϑ <sub>u min</sub> | = -20 °C  |
|                                   | ϑ <sub>u max</sub> | = 60 °C   |

## Materials

|                          |                |  |
|--------------------------|----------------|--|
| <b>Pump</b>              | Pump housing   | GG 25, DIN 1691  |
|                          | Gearing        | Steel 1.7139 chemically nickel plated with SiC inclusions  |
|                          | Bearing bushes | Steel ETG 100 chemically nickel plated with SiC inclusions |
|                          | Seal           | FKM  |
| <b>Magnetic coupling</b> | Inner rotor    | Stainless steel 1.4571                                     |
|                          | Split case     | Stainless steel 1.4571                                     |
|                          | Outer rotor    | 355J2F3 (St 52)  |
|                          | Magnets        | Sm2Co17  |

## Magnetic Coupling Torques

|          |       |
|----------|-------|
| MSA 46/6 | 3 Nm  |
| MSA 60/8 | 7 Nm  |
| MSB 60/8 | 14 Nm |

## Selection Assistance

| Pump | Coupling size | permitted power [kW] at n = 750 1/min | Motor-size | permitted power [kW] at n = 1000 1/min | Motor-size | permitted power [kW] at n = 1500 1/min | Motor-size | permitted power [kW] at n = 3000 1/min | Motor-size |
|------|---------------|---------------------------------------|------------|--|------------|--|------------|--|------------|
| KF 0 | MSA 46        | 0.12                                  | 71         | 0.18                                   | 71         | 0.12                                   | 63         | 0.25                                   | 63         |
|      |               | -                                     | -          | -                                      | -          | 0.18                                   | 63         | 0.37                                   | 71         |
|      |               | -                                     | -          | -                                      | -          | 0.25                                   | 71         | 0.55                                   | 71         |
|      | MSA 60        | 0.18                                  | 80         | 0.25                                   | 71         | 0.37                                   | 71         | 0.75                                   | 80         |
|      |               | 0.25                                  | 80         | 0.37                                   | 80         | 0.55                                   | 80         | 1.1                                    | 80         |
|      | MSB 60        | 0.37                                  | 90         | 0.55                                   | 80         | 0.75                                   | 80         | 1.5                                    | 90         |
|      |               | 0.55                                  | 90         | 0.75                                   | 90         | 1.1                                    | 90         | 2.2                                    | 90         |

The values stated in the table refer to a maximum media temperature of 80 °C.

At media temperatures > 80 °C are to be selected if necessary stronger magnetic couplings.

### To design the magnetic coupling, the following information needs to be available:

- Pump size
- Pump pressure (working and starting pressure)
- Working and starting viscosity
- Precise name of media – required static seals (if possible) – possibly main media characteristics
- Drive motor power
- Speed or speed range
- Switch on type – direct or with frequency inverter
- Media and ambient temperature

Type Key

Ordering example

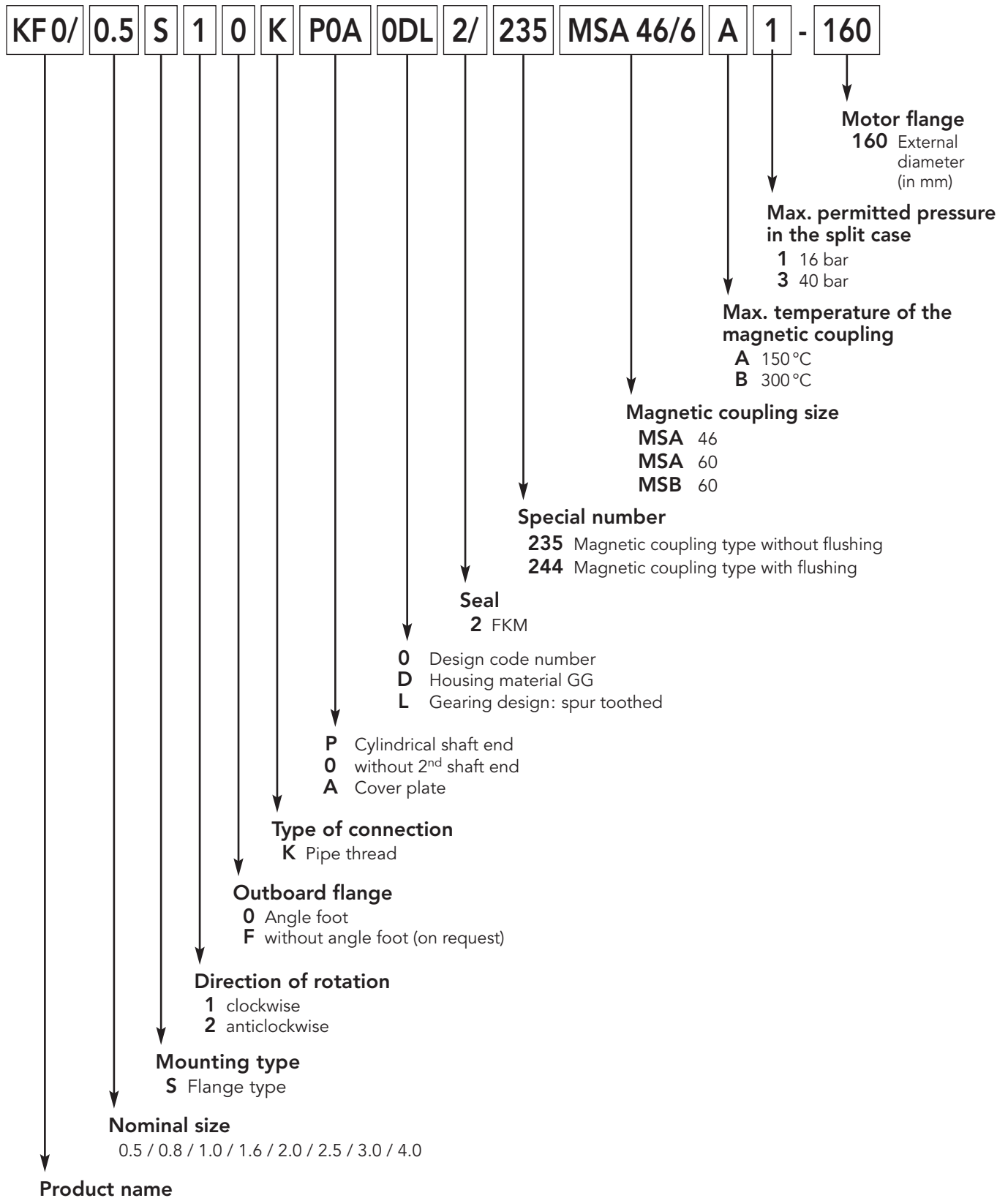

# Product Portfolio

## Gear Pumps

Gear pumps for lubricating oil supply equipment, low pressure filling and feed systems, dosing and mixing systems.

## Mobile Hydraulics

Single and multistage high pressure gear pumps, hydraulic motors and valves for construction machinery, vehicle-mounted machines.

## Flow Measurement

Gear, turbine and screw type flow meters and electronics for volume and flow metering technology in hydraulics, processing and laquering technology.

## Industrial Hydraulics / Test Bench Construction

Cetop directional control and proportional valves, hydraulic cylinders, pressure, quantity and stop valves for pipe and slab construction, hydraulic accessories for industrial hydraulics (mobile and stationary use).

Technology Test benches / Fluid Test benches.



*KF0-KF0 with magn. coupl./GB/12.16*

# KRACHT

KRACHT GmbH · Gewerbestraße 20 · 58791 Werdohl, Germany · Phone +49 23 92.935-0 · Fax +49 23 92.935 209

Email [info@kracht.eu](mailto:info@kracht.eu) · Web [www.kracht.eu](http://www.kracht.eu)