



**Machine safety
Food & packaging**



Precise, safe,

SAFE CONDITION DETECTION

Safety sensors RFID

- Series connection up to PL e / SIL3
- Can be used as stand-alone solution without additional safety controller
- High protection classes IP67 and IP6K9K for use in adverse environmental conditions

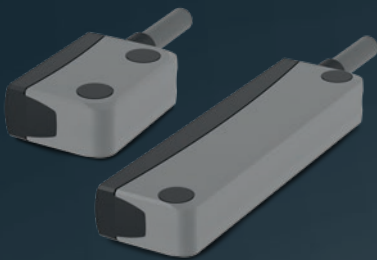

Magnetically actuated safety sensors

- Wide range of products offering solutions for almost every application
- Easy system and machine integration due to various connection options
- Cost-effective and long product lifetime due to contactless sensors and robust housings
- Variants with ATEX approval offer additional possibilities for use

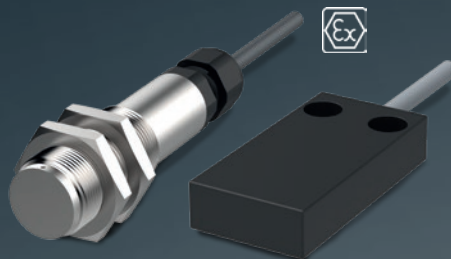

Magnetic safety sensors with integrated evaluation

- No additional safety relay required
- Volt-free safety outputs
- Suitable for applications with 230 V AC operating voltage



Emergency stop buttons & contact elements

- Emergency stop button for direct installation or as add-on variant with housing
- Emergency stop button and contact elements can be freely combined
- Various unlocking devices
- Hygienic version with IP69K for the food industry



Safety interlocks

- Various contact combinations (positively driven N.C. / N.O. contact)
- Up to four horizontal and vertical approach directions
- Closed or open-circuit current principle
- Dirt-proof, dust-proof, and waterproof housing with IP67 protection class



and reliable

SAFE SIGNAL EVALUATION

Configurable safety systems

- eloProg - modular, configurable software, maximum freedom
- eloFlex - configured online, an article number, ideal for production machines
- Configuration software is intuitive to operate
- Stand-alone rotational speed monitoring



Safety control units & Safety relays

- Outputs suitable for any application
- Application-based housing shapes save space in the switch cabinet
- Volt-free relay outputs allow easy integration into any electrical circuit

I/O modules: Interfaces for input expansion and output expansions

- Monitoring of a higher number of safety functions through input expansion
- Output expansion for control of more contactors/motors

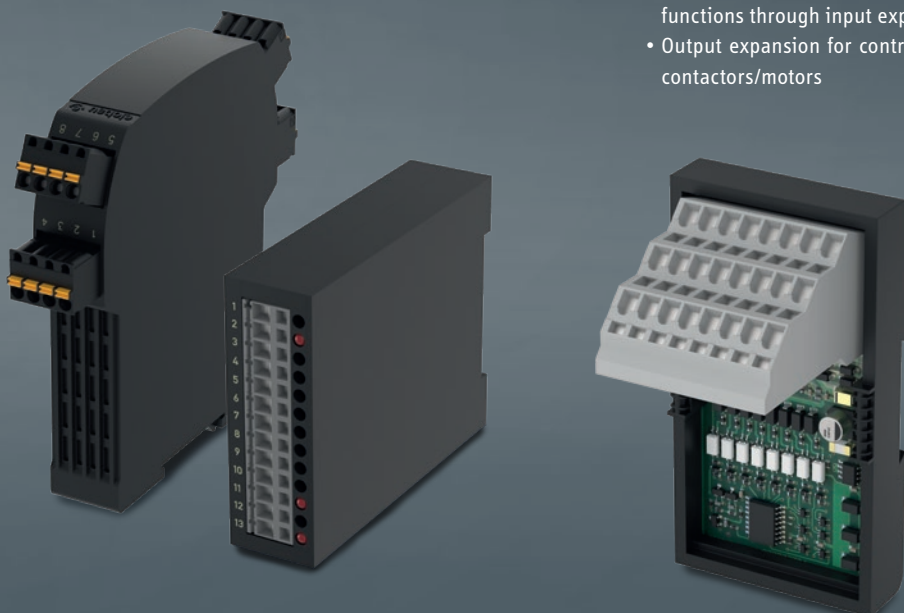

Functional safety for any application

BAND SAWS

In small machines, such as band saws for shredding fish or meat, the space available for electrical components is usually restricted. The smallest and most compact safety system consisting of a safety relay, sensor, and hygienic emergency stop button, offers a solution that is easy to implement structurally.

- 1 Hygienic emergency stop button NHT02D
- 2 Safety sensor M30, 171 series
- 3 Safety control unit, 463 series

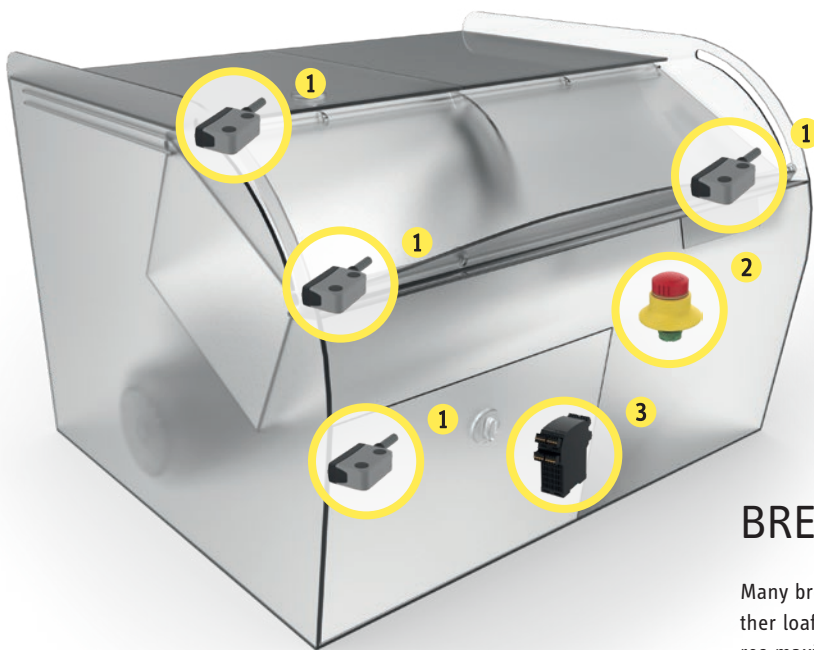

BREAD SLICERS

Many bread slicers allow for a loaf to be positioned while another loaf is already being sliced in a separate area. This requires maximum safety to prevent serious injuries. Magnetically actuated safety sensors can be concealed in order to increase tamper protection. Logical sequences in the workflow can be monitored with configurable safety relays.

- 1 Safety sensors rectangular, small, 153 series
- 2 Emergency stop button, NHT series
- 3 Configurable safety control unit, eloFlex series

Reliable solutions for the protection of processes and people

SLICER

Slicers process sausages, ham, bacon and cheese in a continuous operation, efficiently cutting and weighing at high speed. This requires reliability as well as a high level of safety. Hygiene standards must be met. With products that are specifically made for this sector, elobau offers sensors with stainless steel housings and configurable safety systems.

- 1 Safety sensors M30 stainless steel, 171...V series
- 2 Emergency stop button, NHT series
- 3 Configurable safety system, eloProg / eloFlex series

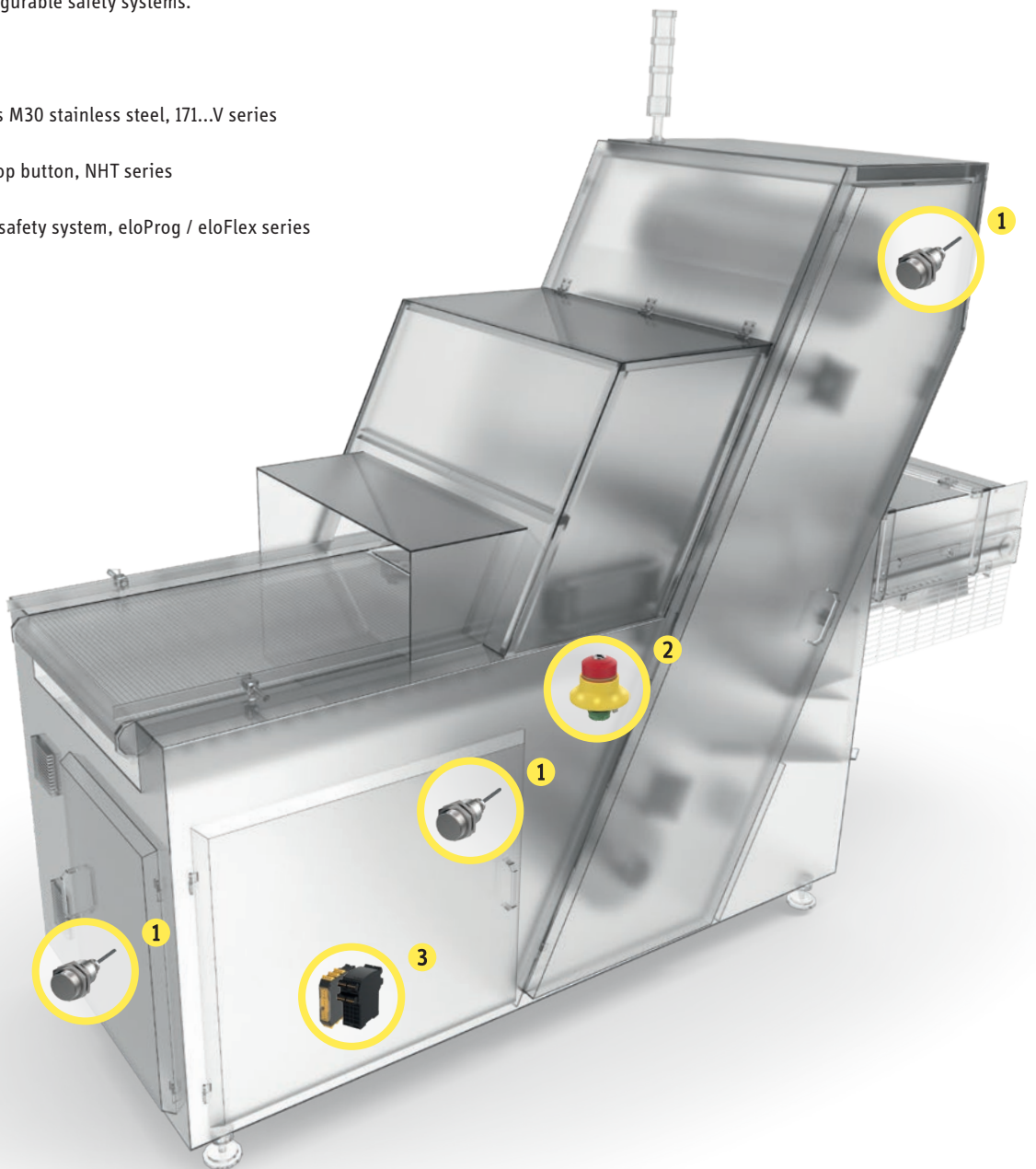

PROTECTING PEOPLE - CONTROLLING MACHINES SAFELY AND EFFICIENTLY. ELOBAU IS COMMITTED TO THE PROTECTION OF PEOPLE AND MACHINERY. ALL OF OUR SAFETY COMPONENTS ARE MATCHED AND CAN BE INDIVIDUALLY CONFIGURED.

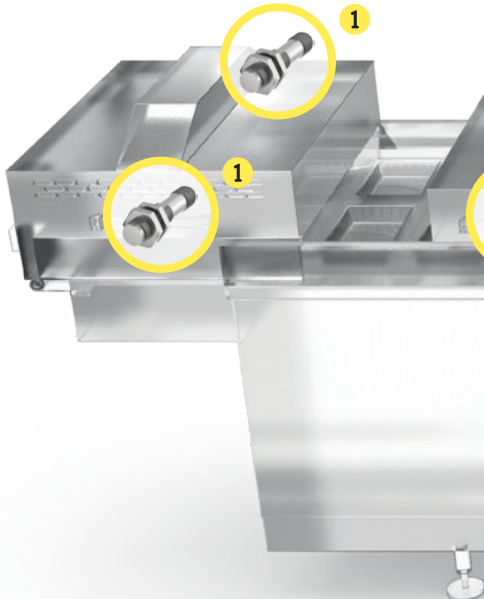

PACKAGING MACHINES

As some guard doors are quite large, safety sensors need to have high offset values. To meet this requirement, the various sensor designs offer offset values of up to 8 mm. The safe interfaces to the input expansion allow that a large number of safety sensors to be easily wired. The eloProtect E series even allows wiring in series to reduce the effort needed and simplify the machine integration.

- 1 Electronic safety sensors eloProtect E, 153ESK / 165ESK series
- 2 Safety relay 470* series (*only with magnetic safety sensors)

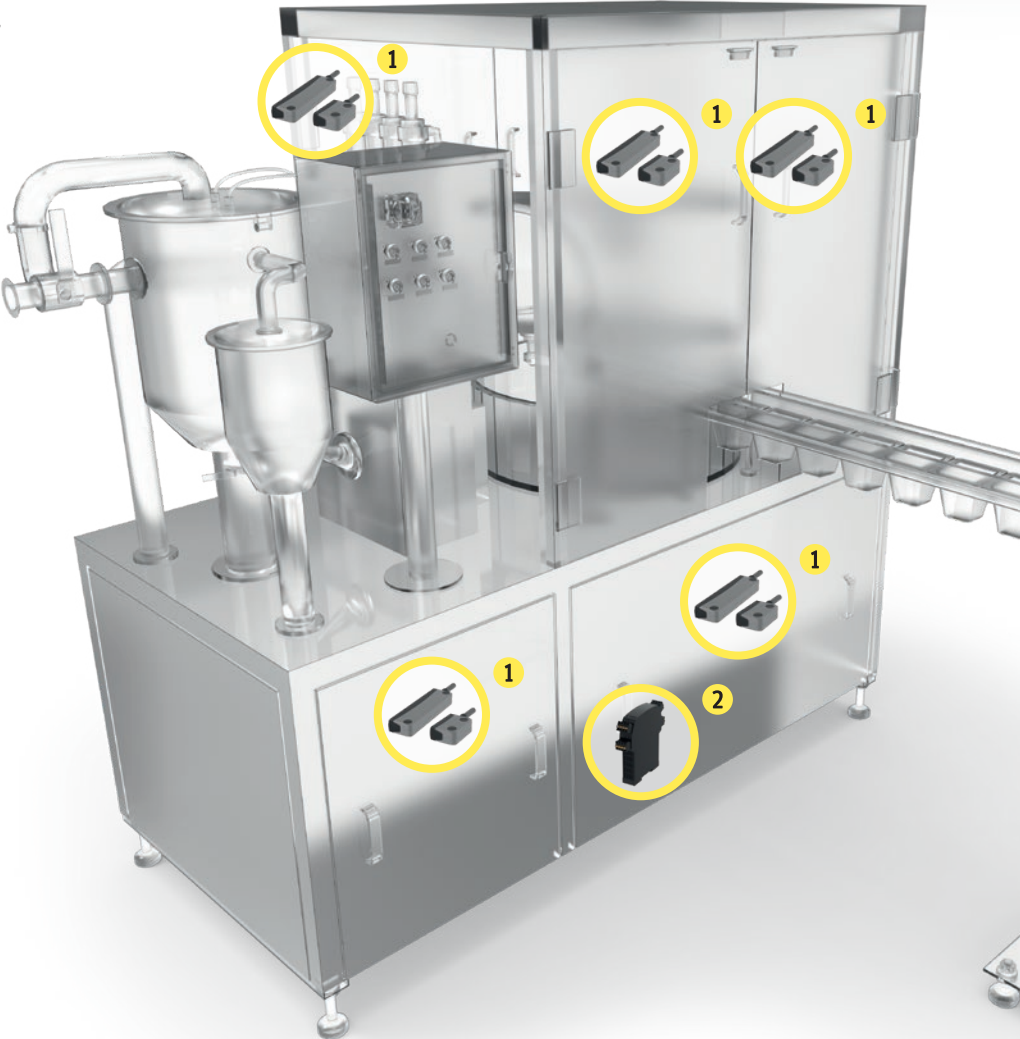

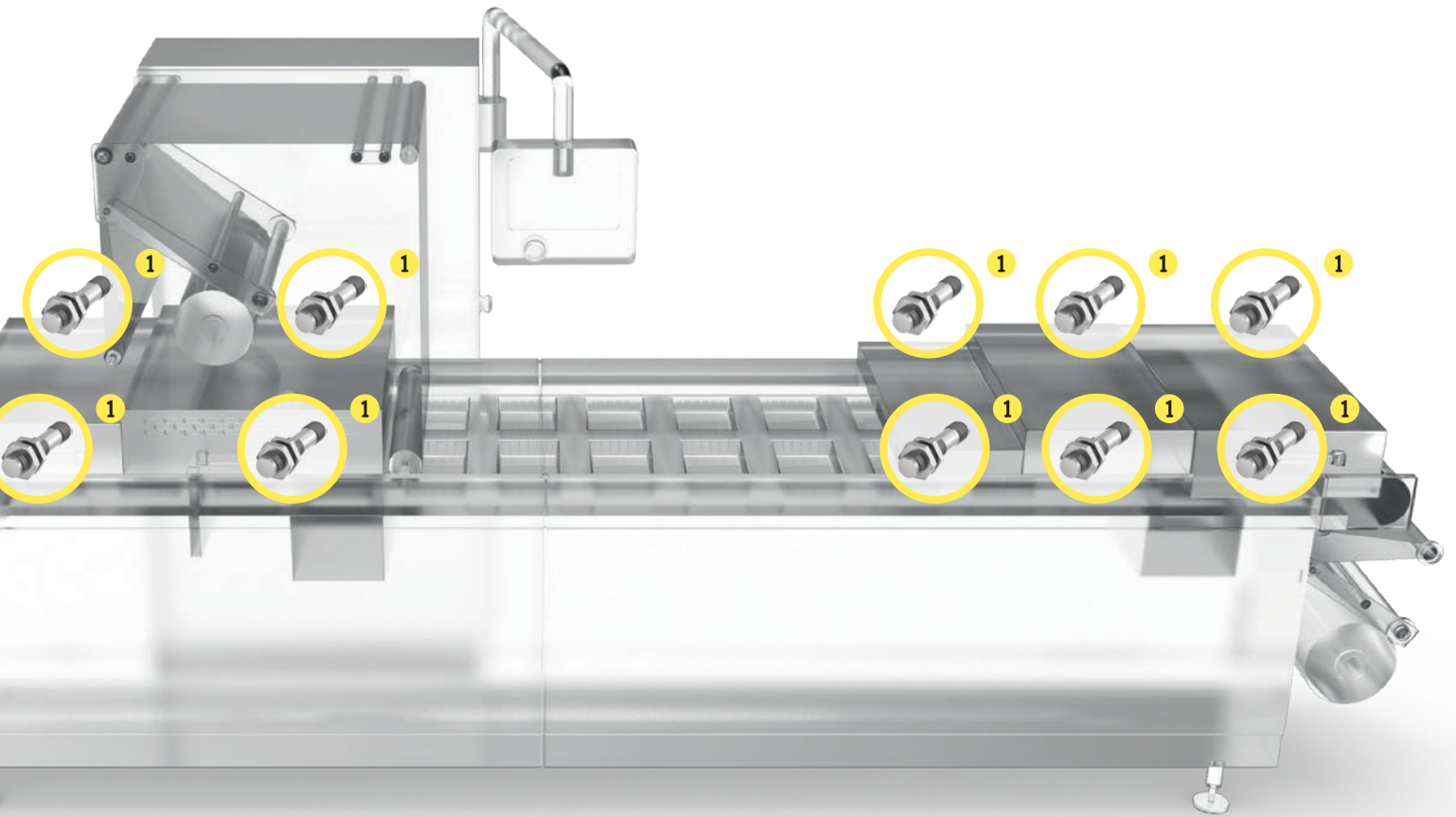

THERMOFORMING MOLD, FILLING AND SEALING MACHINES

A flexible safety solution that enables the decentralisation of individual safety circuits, ideal for modular machine systems.

Unable to find the right solution for your system? In addition to the extensive standard product range, elobau offers customised solutions that are developed, tested, and manufactured to fit your requirements.

- 1 Safety sensors M12, 122 series



WE ARE HAPPY TO ASSIST YOU WITH SELECTING PRODUCTS FOR A TOTAL SOLUTION THAT IS DESIGNED TO FIT YOUR NEEDS. OUR PRODUCTS CAN BE CUSTOMISED TO OFFER A COST-EFFECTIVE SOLUTION FOR YOUR INDIVIDUAL REQUIREMENTS.



elobau

Included on our delivery notes are components, systems and solutions for off-highway vehicles, machine safety and level measurement. Everything based on contactless sensor technology. Everything customised. Everything of high quality.

What doesn't appear on our delivery notes: future security. Our expertise is included in the purchase of every product. Everything that our company does is focused on being a reliable partner for the long term – for our customers, employees and for our ecological and social environment. From the way in which we develop and produce our products to our view of the holistic responsibility of a company.

As an expanding, globally active, family-run foundation company with more than 800 employees, we develop and manufacture sensor technology and operator interface controls for the industrial machine and off-highway vehicle sectors. Our high-quality products are characterised by a high vertical range of manufacture in Germany. With our innovative, contactless sensor products, we support our customers worldwide in manufacturing industrial machines and off-highway vehicles that set standards in terms of performance, operating comfort, safety and quality.

Your partner. Worldwide.

Select your direct contact person
www.elobau.com ▶ Contact



We produce in a
carbon-neutral manner.

elobau 

GmbH & Co. KG
Zeppelinstr. 44
88299 Leutkirch
Germany

☎ + 49 (0) 7561 970-0
☎ + 49 (0) 7561 970-100
www.elobau.com
info@elobau.de