

# Kollmorgen Direct Drive Linear Motor Selection Guide

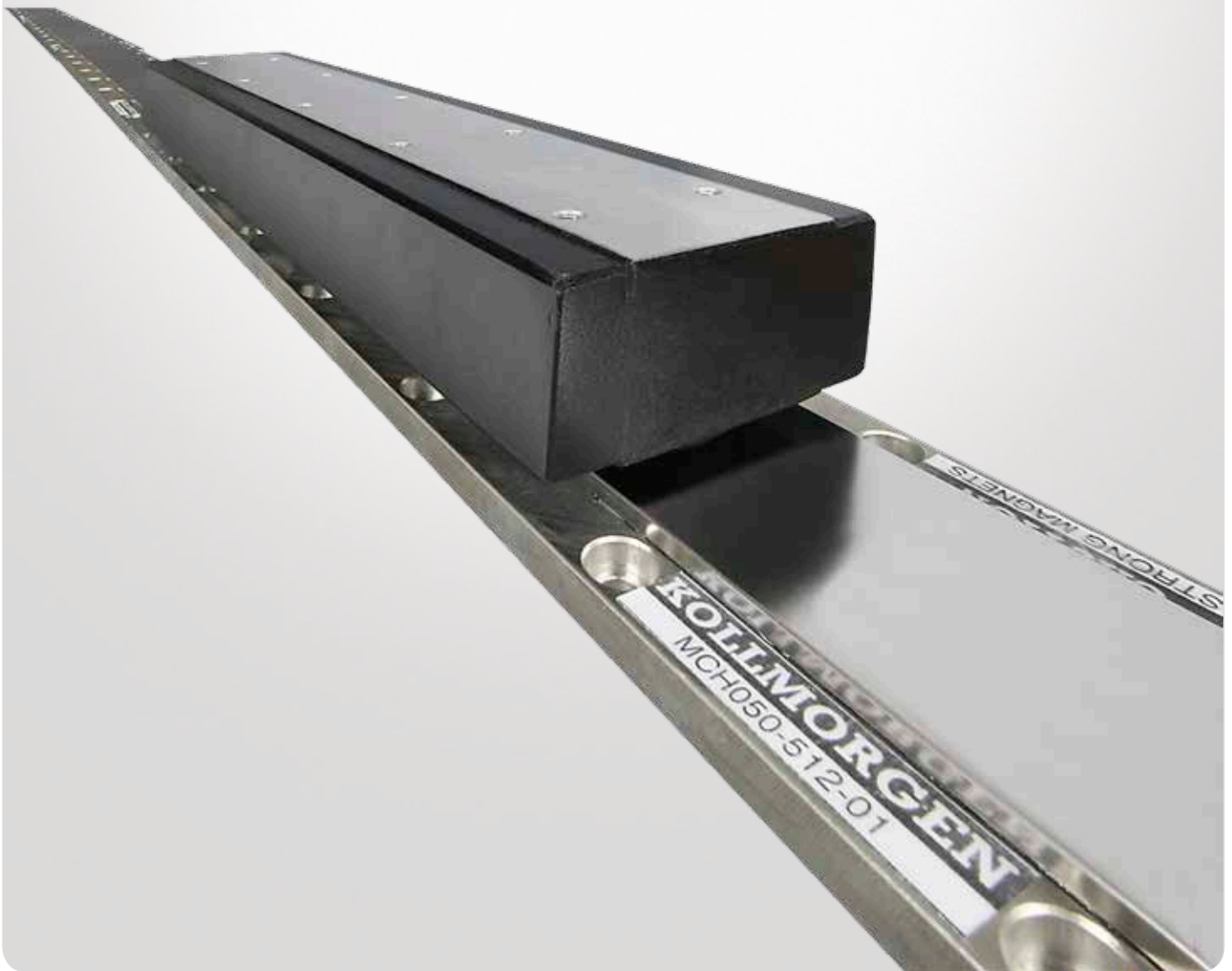

**KOLLMORGEN**

*Because Motion Matters™*

# Kollmorgen. Every solution comes from a real understanding of OEM challenges facing machine designers and users.

**Escalating demands of the marketplace mean increased pressure on machine designers and users at every turn.** Time constraints, demand for better performance, and consideration of next-generation machine technologies are just a few of the demands on today's machine designers and end users. While expectations are enormous, budgets are not. Kollmorgen's innovative automation solutions and broad range of quality motion products help engineers not only overcome these challenges but also build truly differentiated machines.

**Because motion matters, it's our focus.** Motion can distinctly differentiate a machine and deliver a marketplace advantage by improving its performance. This translates to overall increased efficiency on the factory floor. Perfectly deployed machine motion can make your customer's machine more reliable and efficient, enhance accuracy and improve operator safety. Motion also represents endless possibilities for innovation. We've always understood this potential, and thus, have kept motion at our core, relentlessly developing products that offer precision control of speed, accuracy and position in machines that rely on complex motion.

**Removing the Barriers of Design, Sourcing, and Time**

At Kollmorgen, we know that OEM engineers can achieve a lot more when obstacles aren't in the way. So, we clear obstacles in three important ways:

**Integrating Standard and Custom Products**

The optimal solution is often not clear-cut. Our application expertise allows us to modify standard products or develop totally custom solutions across our whole product portfolio so that designs can take flight.

**Providing Motion Solutions, Not Just Components**

As companies reduce their supplier base and have less engineering manpower, they need a total system supplier with a wide range of integrated solutions. Kollmorgen offers complete solutions as well as motion subsystems that combine programming software, engineering services and best-in-class motion components.

**Global Footprint**

With direct sales, engineering support, manufacturing facilities, and distributors across North America, Europe, and Asia, we're close to OEMs worldwide. Our proximity helps speed delivery and lend support where and when they're needed.

**Financial and Operational Stability**

Kollmorgen is part of Fortive. A key driver in the growth of all Fortive divisions is the Fortive Business System, which relies on the principle of "kaizen" – or continuous improvement. Using world-class tools, cross-disciplinary teams of exceptional people evaluate processes and develop plans that result in superior performance.

# Table of Contents

▶ <b>Direct Drive Linear (DDL) Motor</b>	4
▶ <b>Direct Drive Linear Motor Summary</b>	10
▶ <b>DDL Ironcore ICH Motor</b>	
<b>ICH11 Series</b>	12
<b>ICH22 Series</b>	14
<b>ICH33 Series</b>	16
<b>ICH44 Series</b>	18
▶ <b>Ironcore Magnet Ways</b>	20
▶ <b>DDL Ironless IL Motor</b>	
<b>IL06 Series</b>	22
<b>IL12 Series</b>	24
<b>IL18 Series</b>	26
<b>IL24 Series</b>	30
▶ <b>Ironless Magnet Ways</b>	32
▶ <b>Wiring and Output</b>	36
▶ <b>Application Sizing</b>	38
▶ <b>Model Nomenclature</b>	42

# Direct Drive Linear Motor

Our direct drive linear motor series provides new dimensions in performance with high throughput, accuracy, and zero maintenance. A linear motor is a frameless, permanent magnet, three phase, brushless servo motor. The product line consists of two fundamental constructions, Ironless (slotless) and Ironcore. Ironless motors have no attractive force between the frameless components and zero cogging for ultra smooth motion. Ironcore motors provide the highest force per frame size and feature an anti-cogging design which yields extremely smooth operation.

## The Benefits of Direct Drive Linear Motor

- Zero Maintenance with Greater Accuracy and Higher Bandwidth
  - Smoother velocity and reduced audible noise
  - Power transmission without backlash
  - Transmission elements such as couplings, toothed belts, ball/lead screws, rack & pinions, and other fitted components can be eliminated
  - No gears or screws, no lubrication required
  - Improved machine reliability
- Wide Range of Sizes and Force to cover any Linear Application
  - Increased performance for the entire system
  - Flat, compact drive solution
  - Easy mix and match motors and drives
  - Real-life acceleration up to 10 G
- Simplified, High Force Permanent Magnet Design
  - Higher bandwidth and faster response than ball/lead screws or rack & pinion solutions
  - Rapid indexing of heavy loads with peak force up to 12700 N
  - Fewer parts and lower cost of ownership
  - More compact machine design
  - No cogging and no attractive force (ironless motors)

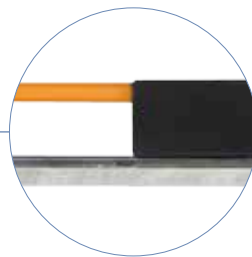
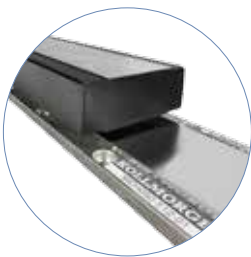

# Direct Drive Linear Motor Overview

## Kollmorgen Direct Drive Linear DDL Motor Series

Kollmorgen supplied its first linear motors in the late 1970's for use in precision X-Y tables and coating systems. These were brush DC motors using the Kollmorgen patented push-through commutator bar method. This led to the 1980's development of the brushless versions of the linear motor which were used in film processing applications where smooth, high stiffness, linear motion was required. During the past 30 years, advances in permanent magnet material, power semiconductors, and microprocessor technology have been the enablers for increased performance and lower costs for linear motors.

*DDL motors series ICH comply with the Low Voltage Directive 2014/35/EC for installation in a machine. Safety depends upon installing and configuring motor per the manufacturer's recommendations. The machine in which this product is to be installed must conform to the provisions of EC directive 2014/30/EC.*



**Ironless Motor**



**Ironcore Motor**

## Standard Product Features

### Ironcore:

- Peak force ICH series: 405 N to 12726 N
- Continuous force ICH series: 175 N to 5341 N
- Anti-cogging technique for minimal cogging without magnet skewing
- High motor constant ( $K_m$ )
- High force density
- Thermal protection PTC and KTY84-130
- Stainless steel magnet way covers
- Isolation system for 480 V AC

### Ironless:

- Peak force 60 N to 1600 N
- Continuous force 21 N to 450 N
- Zero cogging
- Zero attractive force
- Smooth motion for speed as low as 1 micron/second
- Low mass coil assembly for high acceleration
- Isolation system for 230 V AC

### All Motors:

- Zero contact, zero maintenance, brushless design
- 3 phase sinusoidal commutation
- Peak accelerations easily above 10 G
- High position accuracy and resolution
- Very low settling time
- Low thermal losses
- Modular magnet design

### Standard Options:

- Hall effect feedback (digital)
- Thermal protection thermistor (PTC, ironless)
- Cable options
- Winding options

Our Direct Drive Linear (DDL) motor series are frameless permanent magnet, three phase brushless servo motors. Fundamentally, a linear motor is a rotary motor that is rolled out flat.

The two primary components of permanent magnet brushless rotary motors are the stator (primary coils) and the rotor (secondary or rotating magnets). In brushless linear motors the rotor is rolled out flat to become the magnet track (also called the magnet way). The primary coils of the rotary motor are rolled out flat to become the coil assembly (also called the slider).

In most brushless linear motor applications it is typical for the magnet way to be stationary and the coil assembly to be in motion, because of the relative masses of the two components. It is also perfectly acceptable, and sometimes advantageous, to reverse this arrangement. The basic electromagnetic operating principles are the same in either case and are identical to those of a rotary motor.

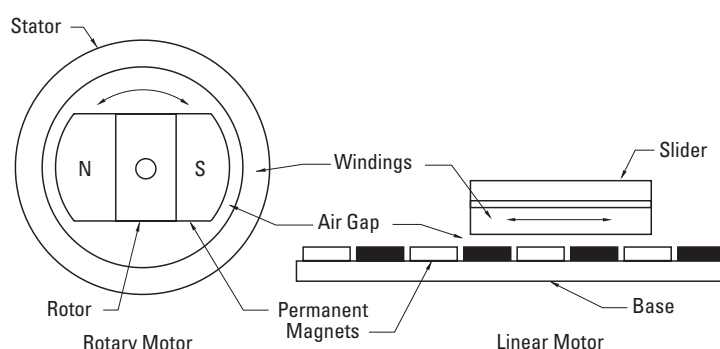

### Rotary Motor Rolled Out Flat

#### Direct Drive Linear Motor Options

Two types of linear motors are available, Ironcore and Ironless. Each one provides characteristics and features that are optimal depending upon the application. Ironcore motors have coils wound on silicon steel laminations, to maximize the generated force, with a single sided magnet way.

Using an innovative electromagnetic design, DDL linear motors have the highest rated force per size, a high  $K_m$  motor constant (equals low thermal losses), and low cogging forces without the need for skewing of the magnets. The high thrust forces possible with these motors make them ideal for accelerating and moving high masses, and

maintaining stiffness during machining or process forces. Ironless motors have no iron, or slots for the coils to be wound on. Therefore, these motors have zero cogging, a very light mass, and absolutely no attractive forces between the coil assembly and the magnet way. These characteristics are ideal for applications requiring very low bearing friction, high acceleration of lighter loads, and for maximizing constant velocity, even at ultra low speeds. The modular magnet ways consists of a double row of magnets to maximize the generated thrust force and to provide a flux return path for the magnetic circuit.

#### Feedback Types

All brushless motors require feedback for commutation. For a linear motor, commutation feedback can also be accomplished with a variety of methods. Digital or linear Hall effect devices are available from Kollmorgen for the DDL motor series which allow the drive electronics to commutate the linear motors in a manner identical to rotary motors.

For exceptionally smooth motion requirements, sinusoidal drive electronics using digital Hall effects, provide sinusoidal drive currents to the motor for the best constant force and velocity performance.

As an alternative, it is typical for linear motor applications to have a linear encoder present in the system for position feedback. It is increasingly common today for drive amplifiers to derive the necessary commutation information directly from this linear encoder, either with or without supplemental digital Hall effect devices on startup.

# Direct Drive Linear Motor Overview

## Advantages

### Wide Speed Range

Since the frameless parts of the linear motor are non-contact, and no limitations of a mechanical transmission are present, both very high speeds and very low speeds are easily obtainable. Speeds are truly not limited by the motor. Instead, by eliminating the mechanical transmission, speed becomes limited by other elements in the system such as the linear bearings, and the achievable bandwidth from any feedback devices. Application speeds of greater than 5 meters per second or less than 1 micron per second are typically achievable. In comparison, mechanical transmissions such as ball screws are commonly limited to linear speeds of 0.5 to 0.7 meters per second because of resonances and wear. In addition to a wide speed range, linear motors, both ironcore and ironless, have excellent constant velocity characteristics, typically better than  $\pm 0.01\%$  speed variation.

### High System Dynamics

In addition to high speed capability, direct drive linear motors are capable of very high accelerations. Limited only by the system bearings, accelerations of 3 to 5 G are quite typical for the larger motors and accelerations exceeding 10 G are easily achievable for smaller motors.

### Easy Selection process:

1. Determine peak and continuous force required for your applications (see our applications section on pages 38-41)
2. Use the motor selection guide on pages 8-9 to choose your motor
3. Refer to the appropriate pages in the data publication for technical details
4. Build model number for ordering using pages 42-44

### Smooth Operation and Positional Accuracy

Both ironless and ironcore motors exhibit very smooth motion profiles due to the inherent motor design of Kollmorgen's DDL series. Cogging, which is a component of force, is greatly reduced in the ironcore designs and is zero in the ironless designs. As a result, these direct drive linear motors provide very low force and velocity ripple for ultra smooth motion. Positioning accuracies are limited only by the feedback resolution, and sub-micron resolutions are commonly achievable.

### Unlimited Travel

With the DDL motor series, magnet ways are made in 4 modular sections: 64 mm, 128 mm, 256 mm and 512 mm long. Each module can be added in unlimited numbers to any other module to allow for unlimited travel. Whether the travel required is 1mm or 100 meters the DDL series can accommodate the need.

### No Wear or Maintenance

Linear motors have few components, therefore the need for ball screw components such as nuts, bearing blocks, couplings, motor mounts and the need to maintain these components have been eliminated. Very long life and clean operation, with no lubrication or maintenance of these parts are the result.

### Integration of Components is Much Simpler

Frameless linear motors require much fewer components than rotary motors with mechanical transmissions. A 0.9 mm airgap for the ironcore design and 0.5 mm airgap for the ironless design is the only alignment of the frameless linear motor components that is necessary. No critical alignments are required as with ball screws. Straightness of travel as provided by the system linear bearings is more than sufficient for the Kollmorgen linear motors.

### Typical Applications for Linear Motors Include:

Machine Tool	Patient table
Drilling	Handling systems
Milling	Measurement/ Inspection
Grinding	Coordinate measurement machines
Laser cutting	Electronic assembly
Cam grinding	Pick-and-place machines
Semiconductor	Component insertion
Wafer handling process	Screen printers
Wafer-inspection	Adhesive dispensers
Wafer slicing	PC-board inspection. drilling
Tab bonding	
Wire bonding	Other applications include:
Ion implantation	Flight Simulators
Lithography	Acceleration sleds
Textile	Catapult
Carpet tufting	G-Force measurement
Plasma cutting	
Polishing	
Preform injection (plastics)	



# Notes



# Direct Drive Linear Motor Summary

## Ironcore Linear Motors

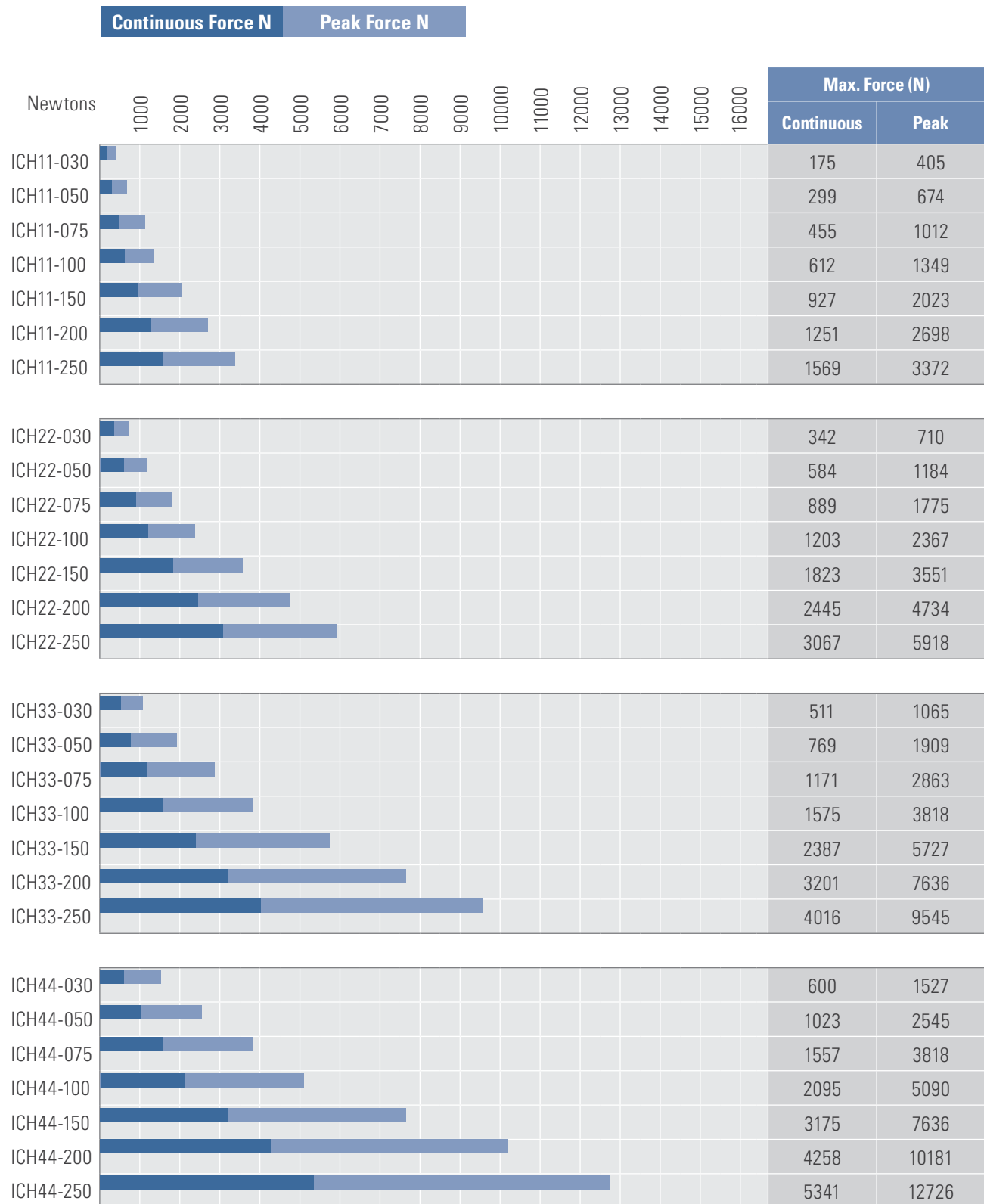

# Direct Drive Linear Motor Summary

## Ironless Linear Motors

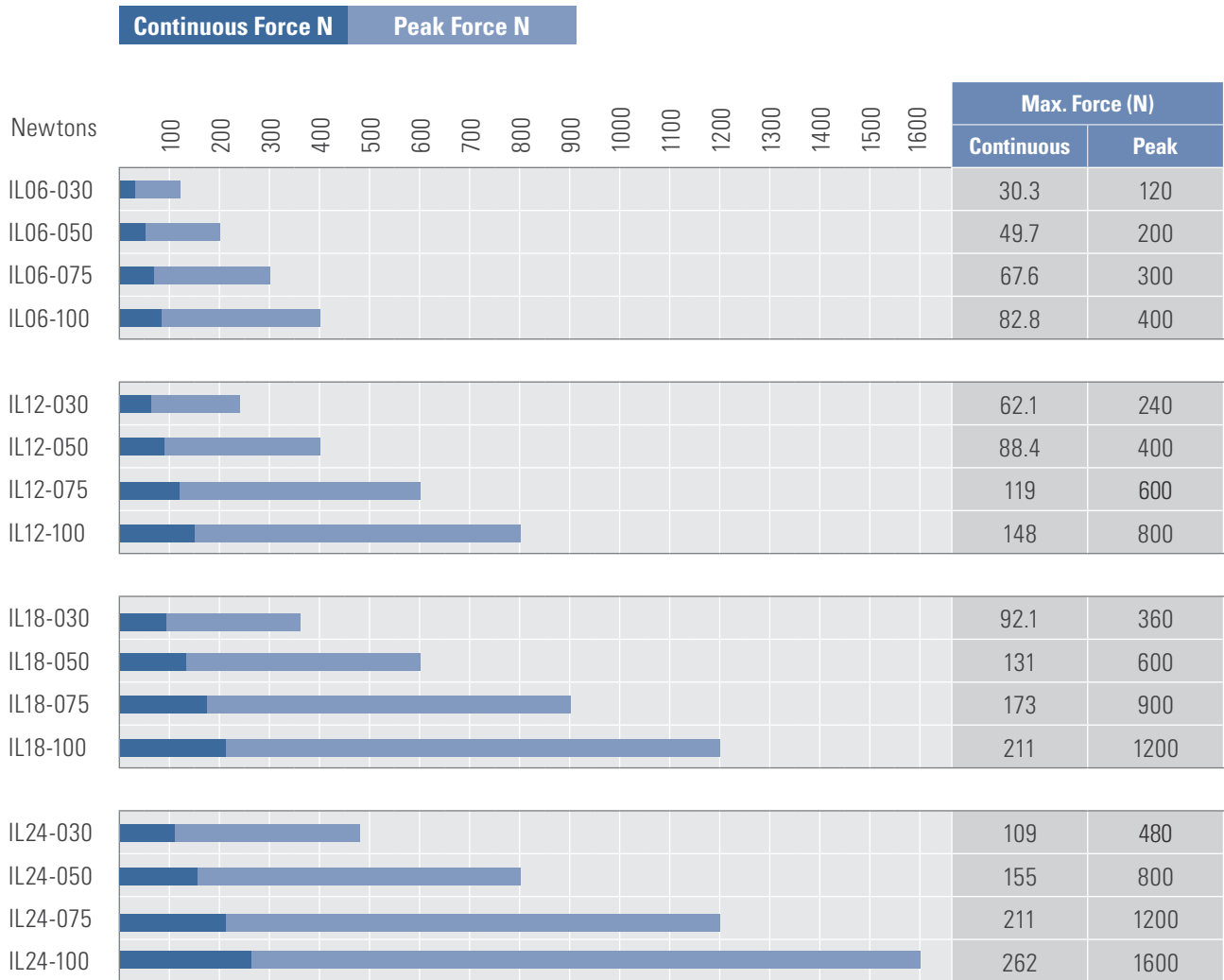

# ICH11 Performance Data

## Ironcore Motors Series

Rated Performance	Symbol	Units	ICH11-030	ICH11-050	ICH11-075	ICH11-100	ICH11-150	ICH11-200	ICH11-250							
Peak Force	Fp	N	405	674	1012	1349	1909	2545	3182							
Continuous Force @ Tmax (1)	Fc	N	175	299	455	612	894	1200	1507							
Motor Constant @ 25°C	Km	N/√W	26	38	49	59	72	85	96							
Electrical Specifications (2)																
Winding Code (5)			A1	A5	A1	A5	A1	A5	A1	A5	A1	A5	A1	A5	A1	A5
Peak Current	Ip	Arms	8.9	15.5	8.9	15.5	8.9	15.5	8.9	15.5	15.3	26.5	15.3	26.5	15.3	26.5
Continuous Current @Tmax	Ic	Arms	2.9	5.0	2.9	5.1	3.0	5.2	3.0	5.2	5.2	9.0	5.2	9.0	5.2	9.1
Electrical Resistance @ 25°C ±10%	Rm	Ohms L-L	3.8	1.3	5.1	1.7	6.7	2.2	8.3	2.8	3.8	1.3	4.9	1.6	5.9	2.0
Electrical Inductance ±20%	L	mH L-L	47	16	78	26	117	39	156	52	80	27	106	35	133	44
Back EMF Constant @ 25°C ±10%	Ke	V <sub>peak</sub> /(m/s) L-L	49	28	82	47	122	71	163	94	141	81	188	108	235	135
Force Constant @ 25°C ±10%	Kf	N/Arms	61	35	102	59	152	88	203	117	173	100	230	133	287	166
Mechanical Specifications																
Coil Assembly Mass ±15%	Mc	kg	2.5	3.5	4.8	6.1	8.6	11.2	13.8							
Magnetic Way Type			MCH030	MCH050	MCH075	MCH100	MCH150	MCH200	MCH250							
Magnetic Way Mass ±15%	Mw	kg/m	5.4	7.6	10.4	13.2	18.8	24.4	30.0							
Figures of Merit and Additional Data																
Electrical Time Constant	Te	ms	12.5	15.4	17.5	18.8	21.0	21.8	22.4							
Max.Theoretical Acceleration (3)	Amax	m/s <sup>2</sup>	161	191	210	222	234	241	245							
Max. Allowable Coil Temp. (4)	Tmax	°C	145	145	145	145	145	145	145							
Cable Diameter	Dc	mm	9.7	9.7	9.7	9.7	9.7	9.7	9.7							
Magnetic Attraction Force	Fa	kN	1.2	2.1	3.1	4.1	6.2	8.3	10.4							
Thermal Resistance of Forcer, Air Cooling	Rta	K/W	1.53	1.22	0.94	0.75	0.53	0.41	0.33							

Notes:

1. The motor continuous force is measured with the motor coils achieving the motor maximum allowable temperature Tmax.
2. Alternate windings are available on request. Please consult the Kollmorgen Customer Support for design options.
3. Maximum theoretical acceleration is based on the motors peak force and the motor mass alone. Limitations due to such factors as the additional mass of the load, the bearing type and design, the shock rating of the feedback, the peak current available from the amplifier etc. must be considered to determine the achievable acceleration in each application.
4. Please see our application sizing pages in the back of this guide for more details on sizing and thermal considerations.
5. Winding phase connection: A1: Y (star) windings, A5: Δ (triangle) windings



# ICH11 Outline Drawings

## Ironcore Motors Series

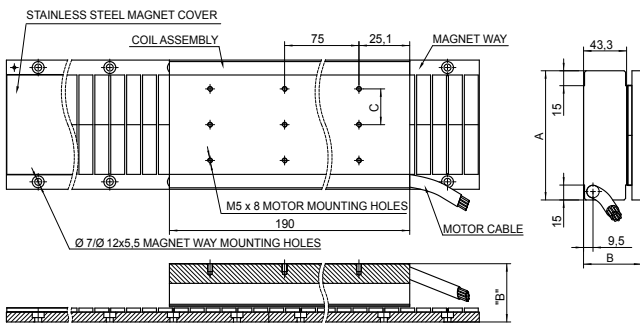

Motor Coil Type	Coil Width	Motor Height	Hole Grid Spacing
	A (mm)	B (mm)	C (mm)
ICH11-030	60.0±1.0	58.6±0.1	16.0
ICH11-050	80.0±1.0	58.6±0.1	36.0
ICH11-075	105.0±1.0	58.6±0.1	32.0
ICH11-100	130.0±1.0	58.6±0.1	36.0
ICH11-150	180.0±1.0	60.6±0.1	32.0
ICH11-200	230.0±1.0	60.6±0.1	36.0
ICH11-250	280.0±1.0	62.6±0.1	32.0

Resultant airgap = 0.9 mm nominal (0.5 mm minimum) when components are set up to dimension "B" in table above.  
 Number of holes and typical installation of multiple ironcore magnet assemblies: please refer to page 21

## Cable Option Flying Leads

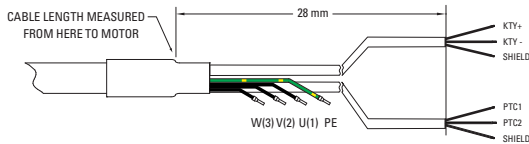

Leads	Cable Length (mm)
C1	400
C2	200
C3	100
C4	1200

## Cable Option Connector on the Cable (Only available for Motors with $I_c < 15 A$ )



Pin side view (mating view)

Extension with pins:  
 BKUA-MR24-42-0035-000  
 Suggested mating connector  
 BSTA-108-FR05-08-0036-000 (cable mounted) or  
 BDFA-108-FR05-00-0150-000 (flange mounted)

Connector	Cable Length (mm)
P1	400
P2	200
P3	100
P4	1200

Shield is connected to motor core and connectors case

## Cable Types

Motor Coil Type	Cable Type: OLFLEX-SERVO 719 CY 4G ...
ICH11-030 A1/A5	0.75+2x(2X0.34)Ø9.7
ICH11-050 A1/A5	0.75+2x(2X0.34)Ø9.7
ICH11-075 A1/A5	0.75+2x(2X0.34)Ø9.7
ICH11-100 A1/A5	0.75+2x(2X0.34)Ø9.7
ICH11-150 A1	0.75+2x(2X0.34)Ø9.7
ICH11-150 A5	0.75+2x(2x0.34)Ø9.7
ICH11-200 A1	0.75+2x(2x0.34)Ø9.7
ICH11-200 A5	0.75+2x(2x0.34)Ø9.7
ICH11-250 A1	0.75+2x(2x0.34)Ø9.7
ICH11-250 A5	0.75+2x(2x0.34)Ø9.7

## Cable Wire Nomenclature

Function	Cable Ø 9.7 mm	Cable > Ø 9.7 mm	Plug BKUA (Option) (1)
U	Black 1	Black 1	1
V	Black 2	Black 2	3
W	Black 3	Black 3	4
PE	Green/Yellow	Green/Yellow	PE
PTC1	Yellow	Black 5	A
PTC2	Green	Black 6	B
KTY+	White	Black 7	C
KTY-	Brown	Black 8	D

Note 1: Option available only for motors with  $I_c < 15 A$

Note 2: Used KTY type is KTY84-130

# ICH22 Performance Data

## Ironcore Motors Series

Rated Performance	Symbol	Units	ICH22-030	ICH22-050	ICH22-075	ICH22-100	ICH22-150	ICH22-200	ICH22-250							
Peak Force	Fp	N	710	1184	1775	2367	3551	4734	5918							
Continuous Force @ Tmax (1)	Fc	N	342	584	889	1203	1823	2445	3067							
Motor Constant @ 25°C	Km	N/√W	37	53	69	83	106	125	141							
Electrical Specifications (2)																
Winding Code (5)			A1	A5	A1	A5	A1	A5	A1	A5	A1	A5	A1	A5	A1	A5
Peak Current	Ip	Arms	8.9	15.5	8.9	15.5	17.9	30.9	30.6	53.0	30.6	53.0	30.6	53.0	30.6	53.0
Continuous Current @Tmax	Ic	Arms	2.8	4.9	2.9	5.0	5.9	10.2	10.2	17.7	10.4	17.9	10.4	18.0	10.5	18.1
Electrical Resistance @ 25°C ±10%	Rm	Ohms L-L	7.5	2.5	10.1	3.4	3.3	1.1	1.4	0.46	1.9	0.65	2.5	0.83	3.0	1.0
Electrical Inductance ±20%	L	mH L-L	94	31	156	52	59	20	27	9	40	13	53	18	66	22
Back EMF Constant @ 25°C ±10%	Ke	V <sub>peak</sub> /(m/s) L-L	98	57	163	94	122	71	95	55	143	82	190	110	237	137
Force Constant @ 25°C ±10%	Kf	N/Arms	121	70	202	117	151	87	117	68	176	102	235	135	293	169
Mechanical Specifications																
Coil Assembly Mass ±15%	Mc	kg	4.9	6.8	9.3	11.8	16.8	21.7	26.7							
Magnetic Way Type			MCH030	MCH050	MCH075	MCH100	MCH150	MCH200	MCH250							
Magnetic Way Mass ±15%	Mw	kg/m	5.4	7.6	10.4	13.2	18.8	24.4	30.0							
Figures of Merit and Additional Data																
Electrical Time Constant	Te	ms	12.5	15.4	17.5	19.1	20.6	21.4	21.9							
Max.Theoretical Acceleration(3)	Amax	m/s <sup>2</sup>	146	173	190	201	212	218	222							
Max. Allowable Coil Temp. (4)	Tmax	°C	145	145	145	145	145	145	145							
Cable Diameter	Dc	mm	9.7	9.7	9.7	9.7	12.3	9.7	12.3	9.7	12.3	9.7	12.3	9.7	12.3	
Magnetic Attraction Force	Fa	kN	2.4	4.0	6.0	8.0	12.0	16.1	20.1							
Thermal Resistance of Forcer, Air Cooling	Rta	K/W	0.86	0.69	0.53	0.43	0.30	0.23	0.19							

**Notes:**

- The motor continuous force is measured with the motor coils achieving the motor maximum allowable temperature Tmax.
- Alternate windings are available on request. Please consult the Kollmorgen Customer Support for design options.
- Maximum theoretical acceleration is based on the motors peak force and the motor mass alone. Limitations due to such factors as the additional mass of the load, the bearing type and design, the shock rating of the feedback, the peak current available from the amplifier etc. must be considered to determine the achievable acceleration in each application.
- Please see our application sizing pages in the back of this guide for more details on sizing and thermal considerations.
- Winding phase connection: A1: Y (star) windings, A5: Δ (triangle) windings



# ICH22 Outline Drawings

## Ironcore Motors Series

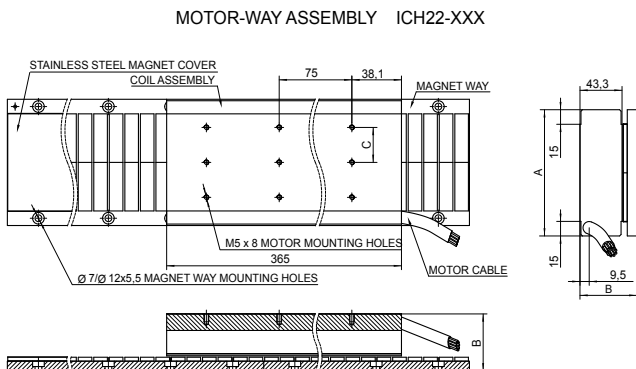

Motor Coil Type	Coil Width	Motor Height	Hole Grid Spacing
	A (mm)	B (mm)	C (mm)
ICH22-030	60.0 ± 1.0	58.6 ± 0.1	16.0
ICH22-050	80.0 ± 1.0	58.6 ± 0.1	36.0
ICH22-075	105.0 ± 1.0	58.6 ± 0.1	32.0
ICH22-100	130.0 ± 1.0	58.6 ± 0.1	36.0
ICH22-150	180.0 ± 1.0	60.6 ± 0.1	32.0
ICH22-200	230.0 ± 1.0	60.6 ± 0.1	36.0
ICH22-250	280.0 ± 1.0	62.6 ± 0.1	32.0

Resultant airgap = 0.9 mm nominal (0.5 mm minimum) when components are set up to dimension "B" in table above.  
 Number of holes and typical installation of multiple ironcore magnet assemblies: please refer to page 21

## Cable Option Flying Leads

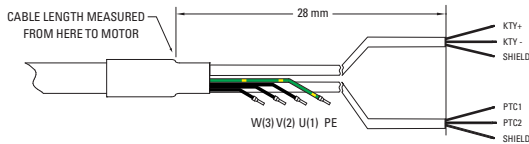

Leads	Cable Length (mm)
C1	400
C2	200
C3	100
C4	1200

## Cable Option Connector on the Cable (Only available for Motors with $I_c < 15 A$ )



Pin side view (mating view)

Extension with pins:  
 BKUA-MR24-42-0035-000

Suggested mating connector  
 BSTA-108-FR05-08-0036-000 (cable mounted) or  
 BDFA-108-FR05-00-0150-000 (flange mounted)

Connector	Cable Length (mm)
P1	400
P2	200
P3	100
P4	1200

Shield is connected to motor core and connectors case

## Cable Types

Motor Coil Type	Cable Type: OLFLEX-SERVO 719 CY 4G ...
ICH22-030 A1/A5	0.75+2x(2X0.34)Ø9.7
ICH22-050 A1/A5	0.75+2x(2X0.34)Ø9.7
ICH22-075 A1	0.75+2x(2X0.34)Ø9.7
ICH22-075 A5	0.75+2x(2x0.34)Ø9.7
ICH22-100 A1	0.75+2x(2x0.34)Ø9.7
ICH22-100 A5	1.50+2x(2x0.75)Ø12.3
ICH22-150 A1	0.75+2x(2x0.34)Ø9.7
ICH22-150 A5	1.50+2x(2x0.75)Ø12.3
ICH22-200 A1	0.75+2x(2x0.34)Ø9.7
ICH22-200 A5	1.50+2x(2x0.75)Ø12.3
ICH22-250 A1	0.75+2x(2x0.34)Ø9.7
ICH22-250 A5	1.50+2x(2x0.75)Ø12.3

## Cable Wire Nomenclature

Function	Cable Ø 9.7 mm	Cable > Ø 9.7 mm	Plug BKUA (Option) (1)
U	Black 1	Black 1	1
V	Black 2	Black 2	3
W	Black 3	Black 3	4
PE	Green/Yellow	Green/Yellow	PE
PTC1	Yellow	Black 5	A
PTC2	Green	Black 6	B
KTY +	White	Black 7	C
KTY -	Brown	Black 8	D

Note 1: Option available only for motors with  $I_c < 15 A$

Note 2: Used KTY type is KTY84-130

# ICH33 Performance Data

## Ironcore Motors Series

Rated Performance	Symbol	Units	ICH33-030	ICH33-050	ICH33-075	ICH33-100	ICH33-150	ICH33-200	ICH33-250							
Peak Force	Fp	N	1065	1909	2863	3818	5727	7636	9545							
Continuous Force @ Tmax (1)	Fc	N	511	769	1171	1575	2387	3201	4016							
Motor Constant @ 25°C	Km	N/√W	45	65	85	101	128	151	171							
Electrical Specifications (2)																
Winding Code (5)			A1	A5	A1	A5	A1	A5	A1	A5	A1	A5	A1	A5	A1	A5
Peak Current	Ip	Arms	8.9	15.5	30.6	53.0	30.6	53.0	30.6	53.0	30.6	53.0	45.9	79.5	45.9	79.5
Continuous Current @Tmax	Ic	Arms	2.8	4.9	8.8	15.2	8.9	15.5	9.0	15.6	9.1	15.8	13.8	23.8	13.8	23.9
Electrical Resistance @ 25°C ±10%	Rm	Ohms L-L	11.3	3.8	1.3	0.42	1.7	0.56	2.1	0.70	2.9	0.97	1.7	0.55	2.0	0.67
Electrical Inductance ±20%	L	mH L-L	141	47	20	7	30	10	40	13	60	20	35	12	44	15
Back EMF Constant @ 25°C ±10%	Ke	V <sub>peak</sub> /(m/s) L-L	147	85	72	41	107	62	143	82	214	123	190	110	237	137
Force Constant @ 25°C±10%	Kf	N/Arms	182	105	88	51	131	76	175	101	262	151	233	134	291	168
Mechanical Specifications																
Coil Assembly Mass ±15%	Mc	kg	7.2	10.2	13.8	17.5	24.9	32.2	39.6							
Magnetic Way Type			MCH030	MCH050	MCH075	MCH100	MCH150	MCH200	MCH250							
Magnetic Way Mass ±15%	Mw	kg/m	5.4	7.6	10.4	13.2	18.8	24.4	30.0							
Figures of Merit and Additional Data																
Electrical Time Constant	Te	ms	12.5	15.6	17.8	19.1	20.6	21.4	21.9							
Max.Theoretical Acceleration(3)	Amax	m/s <sup>2</sup>	148	188	207	218	230	237	241							
Max. Allowable Coil Temp. (4)	Tmax	°C	145	145	145	145	145	145	145							
Cable Diameter	Dc	mm	9.7	9.7 12.3	9.7 12.3	9.7 12.3	9.7 12.3	9.7 14.7	9.7 14.7							
Magnetic Attraction Force	Fa	kN	3.6	6.0	8.9	11.9	17.9	23.8	29.8							
Thermal Resistance of Forcer, Air Cooling	Rta	K/W	0.60	0.48	0.37	0.30	0.21	0.16	0.13							

Notes:

1. The motor continuous force is measured with the motor coils achieving the motor maximum allowable temperature Tmax.
2. Alternate windings are available on request. Please consult the Kollmorgen Customer Support for design options.
3. Maximum theoretical acceleration is based on the motors peak force and the motor mass alone. Limitations due to such factors as the additional mass of the load, the bearing type and design, the shock rating of the feedback, the peak current available from the amplifier etc. must be considered to determine the achievable acceleration in each application.
4. Please see our application sizing pages in the back of this guide for more details on sizing and thermal considerations.
5. Winding phase connection: A1: Y (star) windings, A5: Δ (triangle) windings





# ICH33 Outline Drawings

## Ironcore Motors Series

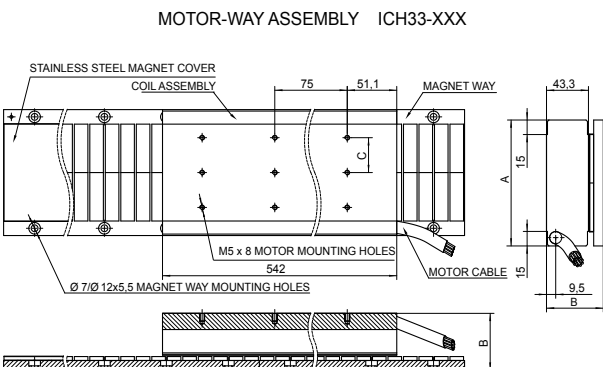

Resultant airgap = 0.9 mm nominal (0.5 mm minimum) when components are set up to dimension "B" in table above.  
 Number of holes and typical installation of multiple ironcore magnet assemblies: please refer to page 21

Motor Coil Type	Coil Width	Motor Height	Hole Grid Spacing
	A (mm)	B (mm)	C (mm)
ICH33-030	60.0±1.0	58.6±0.1	16.0
ICH33-050	80.0±1.0	58.6±0.1	36.0
ICH33-075	105.0±1.0	58.6±0.1	32.0
ICH33-100	130.0±1.0	58.6±0.1	36.0
ICH33-150	180.0±1.0	60.6±0.1	32.0
ICH33-200	230.0±1.0	60.6±0.1	36.0
ICH33-250	280.0±1.0	62.6±0.1	32.0

## Cable Option Flying Leads

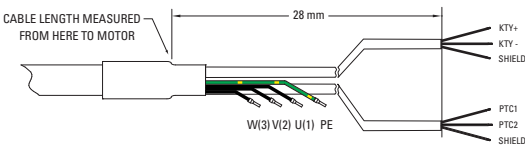

Leads	Cable Length (mm)
C1	400
C2	200
C3	100
C4	1200

## Cable Option Connector on the Cable (Only available for Motors with $I_c < 15 A$ )



Pin side view (mating view)

Extension with pins:  
 BKUA-MR24-42-0035-000  
 Suggested mating connector  
 BSTA-108-FR05-08-0036-000 (cable mounted) or  
 BDFA-108-FR05-00-0150-000 (flange mounted)

Connector	Cable Length (mm)
P1	400
P2	200
P3	100
P4	1200

Shield is connected to motor core and connectors case

## Cable Types

Motor Coil Type	Cable Type: OLFLEX-SERVO 719 CY 4G ...
ICH33-030 A1/A5	0.75+2x(2X0.34)Ø9.7
ICH33-050 A1	0.75+2x(2x0.34)Ø9.7
ICH33-050 A5	1.50+2x(2x0.75)Ø12.3
ICH33-075 A1	0.75+2x(2x0.34)Ø9.7
ICH33-075 A5	1.50+2x(2x0.75)Ø12.3
ICH33-100 A1	0.75+2x(2x0.34)Ø9.7
ICH33-100 A5	1.50+2x(2x0.75)Ø12.3
ICH33-150 A1	0.75+2x(2x0.34)Ø9.7
ICH33-150 A5	1.50+2x(2x0.75)Ø12.3
ICH33-200 A1	0.75+2x(2x0.34)Ø9.7
ICH33-200 A5	2.5+2x(2x1.0)Ø14.7
ICH33-250 A1	0.75+2x(2x0.34)Ø9.7
ICH33-250 A5	2.5+2x(2x1.0)Ø14.7

## Cable Wire Nomenclature

Function	Cable Ø 9.7 mm	Cable > Ø9.7 mm	Plug BKUA (Option) (1)
U	Black 1	Black 1	1
V	Black 2	Black 2	3
W	Black 3	Black 3	4
PE	Green/Yellow	Green/Yellow	PE
PTC1	Yellow	Black 5	A
PTC2	Green	Black 6	B
KTY +	White	Black 7	C
KTY -	Brown	Black 8	D

Note 1: Option available only for motors with  $I_c < 15 A$

Note 2: Used KTY type is KTY84-130

# ICH44 Performance Data

## Ironcore Motors Series

Rated Performance	Symbol	Units	ICH44-030	ICH44-050	ICH44-075	ICH44-100	ICH44-150	ICH44-200	ICH44-250							
Peak Force	Fp	N	1527	2545	3818	5090	7636	10181	12726							
Continuous Force @ Tmax (1)	Fc	N	600	1023	1557	2095	3175	4258	5341							
Motor Constant @ 25°C	Km	N/√W	52	75	98	117	148	175	198							
Electrical Specifications (2)																
Winding Code (5)			A1	A5	A1	A5	A1	A5	A1	A5	A1	A5	A1	A5	A1	A5
Peak Current	Ip	Arms	15.3	26.5	15.3	26.5	30.6	53.0	30.6	53.0	61.2	106.0	61.2	106.0	61.2	106.0
Continuous Current @Tmax	Ic	Arms	4.3	7.4	4.4	7.6	8.9	15.4	9.0	15.6	18.2	31.5	18.3	31.7	18.4	31.8
Electrical Resistance @ 25°C ±10%	Rm	Ohms L-L	5.1	1.7	6.8	2.3	2.2	0.75	2.8	0.93	0.97	0.32	1.2	0.41	1.5	0.50
Electrical Inductance ±20%	L	mH L-L	64	21	106	35	40	13	53	18	20	7	27	9	33	11
Back EMF Constant @25°C ±10%	Ke	V <sub>peak</sub> /(m/s) L-L	115	66	191	110	143	82	190	110	143	82	190	110	237	137
Force Constant @ 25°C ±10%	Kf	N/Arms	140	81	234	135	175	101	233	135	175	101	233	134	291	168
Mechanical Specifications																
Coil Assembly Mass ±15%	Mc	kg	9.6	13.5	18.3	23.2	33.0	42.7	52.5							
Magnetic Way Type			MCH030	MCH050	MCH075	MCH100	MCH150	MCH200	MCH250							
Magnetic Way Mass ±15%	Mw	kg/m	5.4	7.6	10.4	13.2	18.8	24.4	30.0							
Figures of Merit and Additional Data																
Electrical Time Constant	Te	ms	12.6	15.6	17.8	19.1	20.6	21.4	21.9							
Max.Theoretical Acceleration(3)	Amax	m/s <sup>2</sup>	160	189	208	219	232	238	242							
Max. Allowable Coil Temp. (4)	Tmax	°C	145	145	145	145	145	145	145							
Cable Diameter	Dc	mm	9.7	9.7	9.7	12.3	9.7	12.3	12.3	16.4	12.3	16.4	12.3	16.4		
Magnetic Attraction Force	Fa	kN	4.7	7.9	11.9	15.8	23.7	31.6	39.5							
Thermal Resistance of Forcer, Air Cooling	Rta	K/W	0.46	0.37	0.28	0.23	0.16	0.12	0.10							

**Notes:**

- The motor continuous force is measured with the motor coils achieving the motor maximum allowable temperature Tmax.
- Alternate windings are available on request. Please consult the Kollmorgen Customer Support for design options.
- Maximum theoretical acceleration is based on the motors peak force and the motor mass alone. Limitations due to such factors as the additional mass of the load, the bearing type and design, the shock rating of the feedback, the peak current available from the amplifier etc. must be considered to determine the achievable acceleration in each application.
- Please see our application sizing pages in the back of this guide for more details on sizing and thermal considerations.
- Winding phase connection: A1: Y (star) windings, A5: Δ (triangle) windings

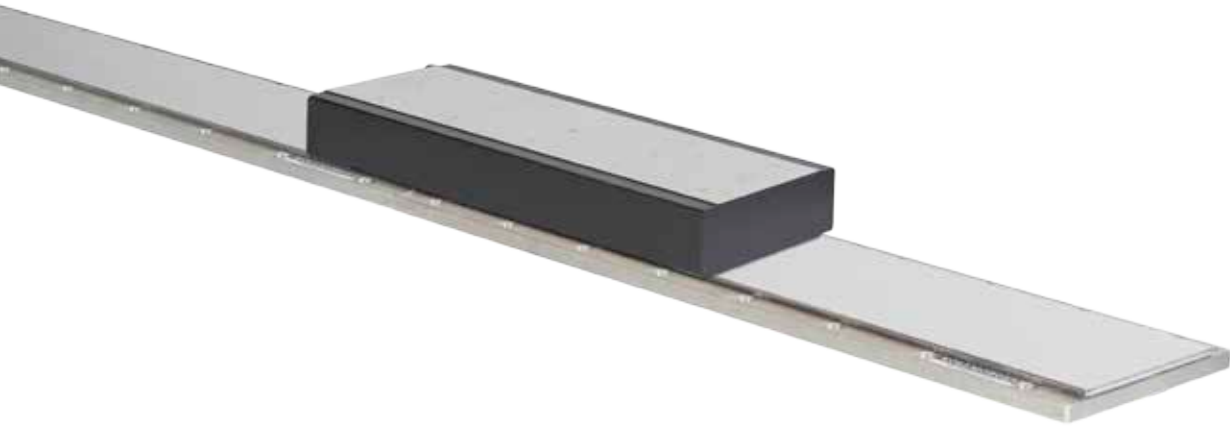

# ICH44 Outline Drawings

## Ironcore Motors Series

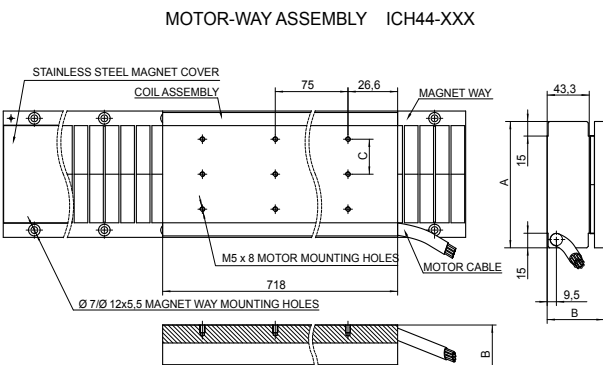

Motor Coil Type	Coil Width	Motor Height	Hole Grid Spacing
	A (mm)	B (mm)	C (mm)
ICH44-030	60.0±1.0	58.6±0.1	16.0
ICH44-050	80.0±1.0	58.6±0.1	36.0
ICH44-075	105.0±1.0	58.6±0.1	32.0
ICH44-100	130.0±1.0	58.6±0.1	36.0
ICH44-150	180.0±1.0	60.6±0.1	32.0
ICH44-200	230.0±1.0	60.6±0.1	36.0
ICH44-250	280.0±1.0	62.6±0.1	32.0

Resultant airgap = 0.9 mm nominal (0.5 mm minimum) when components are set up to dimension "B" in table above.  
Number of holes and typical installation of multiple ironcore magnet assemblies: please refer to page 21

## Cable Option Flying Leads

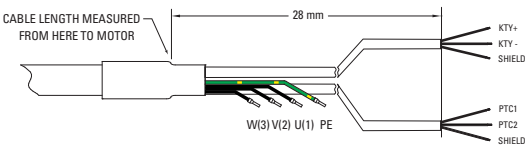

Leads	Cable Length (mm)
C1	400
C2	200
C3	100
C4	1200

## Cable Option Connector on the Cable (Only available for Motors with $I_c < 15 A$ )



Pin side view (mating view)

Extension with pins:  
BKUA-MR24-42-0035-000  
Suggested mating connector  
BSTA-108-FR05-08-0036-000 (cable mounted) or  
BDFA-108-FR05-00-0150-000 (flange mounted)

Connector	Cable Length (mm)
P1	400
P2	200
P3	100
P4	1200

Shield is connected to motor core and connectors case

## Cable Types

Motor Coil Type	Cable Type: OLFLEX-SERVO 719 CY 4G ...
ICH44-030 A1/A5	0.75+2x(2X0.34)Ø9.7
ICH44-050 A1/A5	0.75+2x(2X0.34)Ø9.7
ICH44-075 A1	0.75+2x(2X0.34)Ø9.7
ICH44-075 A5	1.50+2x(2x0.75)Ø12.3
ICH44-100 A1	0.75+2x(2x0.34)Ø9.7
ICH44-100 A5	1.50+2x(2x0.75)Ø12.3
ICH44-150 A1	1.50+2x(2x0.75)Ø12.3
ICH44-150 A5	4.00+2x(2x1.00)Ø16.4
ICH44-200 A1	1.50+2x(2x0.75)Ø12.3
ICH44-200 A5	4.00+2x(2x1.00)Ø16.4
ICH44-250 A1	1.50+2x(2x0.75)Ø12.3
ICH44-250 A5	4.00+2x(2x1.00)Ø16.4

## Cable Wire Nomenclature

Function	Cable Ø12.4 mm	Cable > Ø12.4 mm	Plug BKUA (Option) (1)
U	Black 1	Black 1	1
V	Black 2	Black 2	3
W	Black 3	Black 3	4
PE	Green/Yellow	Green/Yellow	PE
PTC1	Yellow	Black 5	A
PTC2	Green	Black 6	B
KTY +	White	Black 7	C
KTY -	Brown	Black 8	D

Note 1: Option available only for motors with  $I_c < 15 A$

Note 2: Used KTY type is KTY84-130

# Ironcore Magnet Ways

## MCHxxx-064

MCHXXX-064-01

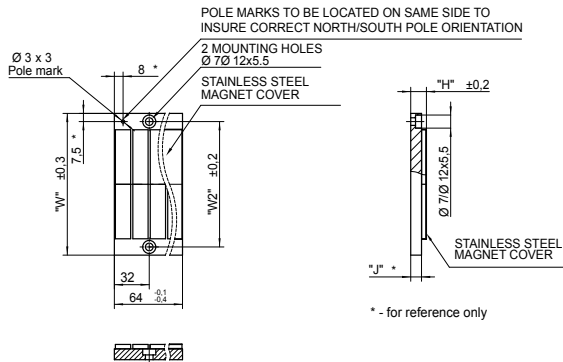

Magnet assemblies are modular and can be installed in multiples of same or alternate lengths. Standard lengths are shown below.

Magnetic Way Type	Assembly Width W (mm)	Mounting Hole Width W2 (mm)	J (mm)	H With Cover (mm)
MCH030-064	60.0	45.0	10.0	14.4
MCH050-064	80.0	65.0	10.0	14.4
MCH075-064	105.0	90.0	10.0	14.4
MCH100-064	130.0	115.0	10.0	14.4
MCH150-064	180.0	165.0	12.0	16.4
MCH200-064	230.0	215.0	12.0	16.4
MCH250-064	280.0	265.0	14.0	18.4

## MCHxxx-128

MCHXXX-128-01

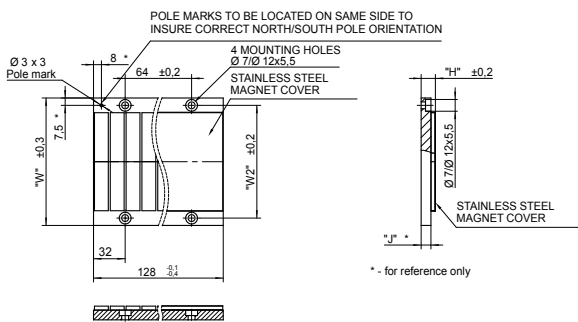

Magnetic Way Type	Assembly Width W (mm)	Mounting Hole Width W (mm)	J (mm)	H With Cover (mm)
MCH030-128	60.0	45.0	10.0	14.4
MCH050-128	80.0	65.0	10.0	14.4
MCH075-128	105.0	90.0	10.0	14.4
MCH100-128	130.0	115.0	10.0	14.4
MCH150-128	180.0	165.0	12.0	16.4
MCH200-128	230.0	215.0	12.0	16.4
MCH250-128	280.0	265.0	14.0	18.4

## MCHxxx-256

MCHXXX-256-01

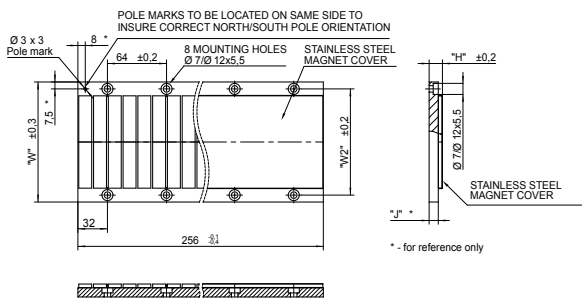

Magnetic Way Type	Assembly Width W (mm)	Mounting Hole Width W2 (mm)	J (mm)	H With Cover (mm)
MCH030-256	60.0	45.0	10.0	14.4
MCH050-256	80.0	65.0	10.0	14.4
MCH075-256	105.0	90.0	10.0	14.4
MCH100-256	130.0	115.0	10.0	14.4
MCH150-256	180.0	165.0	12.0	16.4
MCH200-256	230.0	215.0	12.0	16.4
MCH250-256	280.0	265.0	14	18.4

\* Note: Flatness and height of magnet ways is defined at fastened to the flat base.

## MCHxxx-512

MCHXXX-512-01

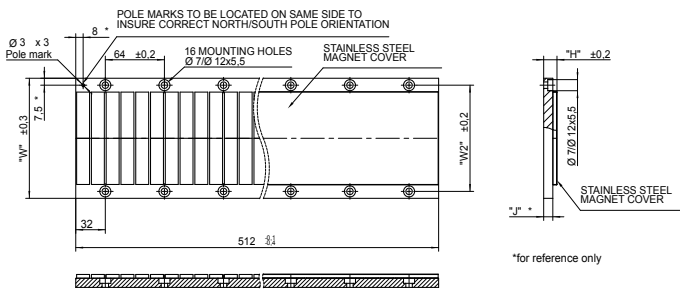

Magnetic Way Type	Assembly Width W (mm)	Mounting Hole Width W2 (mm)	J (mm)	H With Cover (mm)
MCH030-512	60.0	45.0	10.0	14.4
MCH050-512	80.0	65.0	10.0	14.4
MCH075-512	105.0	90.0	10.0	14.4
MCH100-512	130.0	115.0	10.0	14.4
MCH150-512	180.0	165.0	12.0	16.4
MCH200-512	230.0	215.0	12.0	16.4
MCH250-512	280.0	265.0	14	18.4

## Typical Installation of Multiple Ironcore Magnet Assemblies

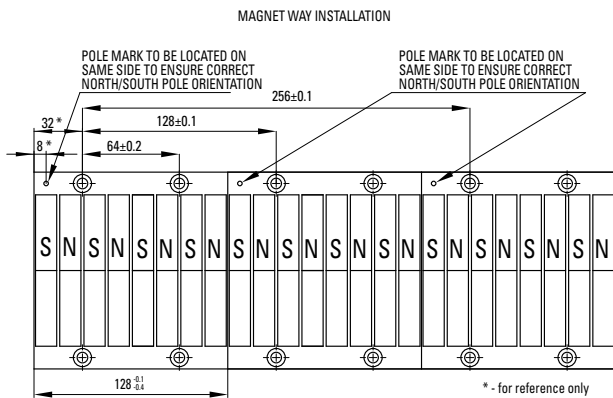

Magnet Way widths correspond to the mating coil assembly width. Magnet Way assemblies are modular and come in standard lengths: 64, 128, 256, 512 mm. Multiple magnet assemblies can be installed to obtain the desired length. Shown below is the method to mount multiple assemblies.

## Typical Mounting Bar Lengths & Mounting Holes Tabulation

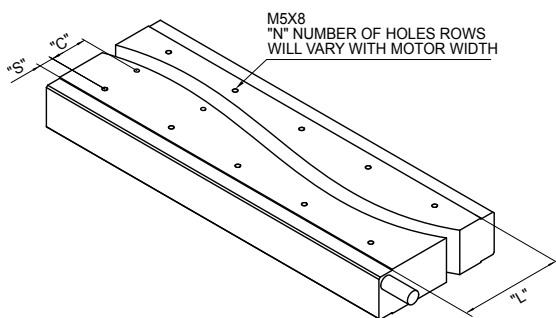

Magnetic Coil Type	Number of Rows N	Spacing Bet. Holes C (mm)	Mounting Bar Length L (mm)	S (mm)
ICHXX-030	2	16.0	30	7.0
ICHXX-050	2	36.0	50	7.0
ICHXX-075	3	32.0	75	5.5
ICHXX-100	3	36.0	100	14.0
ICHXX-150	5	32.0	150	11.0
ICHXX-200	6	36.0	200	10.0
ICHXX-250	8	32.0	250	13

\* Note: Flatness and height of magnet ways is defined at fastened to the flat base.

# IL06 Performance Data

## Ironless Non-Cooled Motors Series

Rated Performance	Symbol	Units	IL06-030	IL06-050	IL06-075	IL06-100				
Peak Force	Fp	N	120	200	300	400				
Continuous Force @ Tmax (1)	Fc	N	30.3	49.7	67.6	82.8				
Motor Constant	Km	N/√W	5.6	8.0	10.2	12.1				
Electrical Specifications (2)										
		Winding Code	A1	A4	A1	A4	A1	A4	A1	A4
Peak Current	Ip	Arms	7.1	14.2	7.0	14.0	7.0	14.0	7.0	14.0
Continuous Current @Tmax	Ic	Arms	1.8	3.6	1.7	3.5	1.6	3.2	1.5	2.9
Electrical Resistance @ 25°C±10%	Rm	Ohms L-L	6.1	1.5	8.6	2.2	11.7	2.9	14.7	3.7
Electrical Inductance ±20%	L	mH L-L	1.3	0.33	3.00	0.75	5.00	1.25	7.00	1.75
Back EMF Constant @ 25°C±10%	Ke	Vpeak/m/s L-L	13.7	6.9	23.3	11.6	34.9	17.5	46.5	23.3
Force Constant @ 25°C±10%	kf	N/Arms	16.8	8.4	28.5	14.3	42.8	21.4	57.0	28.5
Mechanical Specifications										
Coil Assembly Mass ±15%	Mc	kg	0.27	0.32	0.38	0.45				
Magnetic Way Type			MW		MW		MW075	MW075		
			030	030L	050	050L				
Magnetic Way Mass ±15%	Mw	kg/m	9.4	7.3	12.2	10.2	18.9	27.3		
Figures of Merit and Additional Data										
Electrical Time Constant	Te	ms	0.21	0.35	0.43	0.48				
Max.Theoretical Acceleration (3)	Amax	m/s <sup>2</sup>	45.2	63.6	80.6	90.7				
Magnetic Attraction	Fa	kN	0	0	0	0				
Thermal Resistance (4) (Coils to External Structure)	Rth	°C/Watt	1.61	1.26	1.04	0.87				
Max. Allowable Coil Temp. (4)	Tmax	°C	130	130	130	130				

**Notes:**

1. The motor continuous rated force is measured with the motor coils achieving the motor maximum allowable temperature Tmax.
2. Alternate windings can be made available. Please consult the Kollmorgen Customer Support for design options.
3. Maximum theoretical acceleration is based on the motors peak force and the motor mass alone. Limitations due to such factors as the additional mass of the load, the bearing type and design, the shock rating of the feedback, the peak current available from the amplifier etc. must be considered to determine the achievable acceleration in each application.
4. Please see our application sizing pages in the back of this guide for more details on sizing and thermal considerations.

# IL06 Outline Drawings

## Ironless Non-Cooled Motors Series

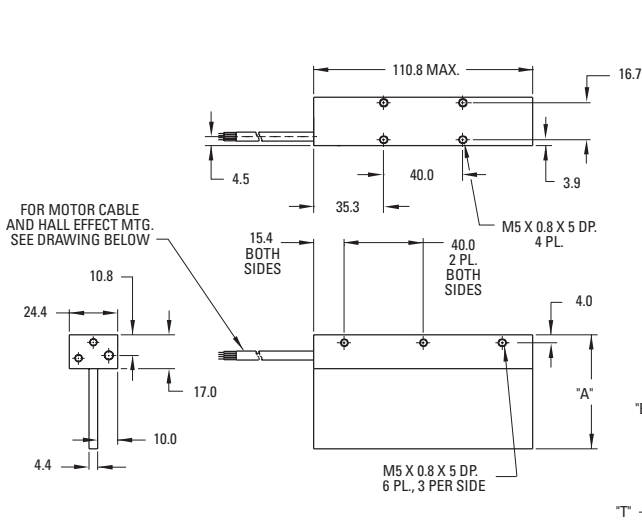

Motor Coil	Coil Width		Typ. Assy. Width	Typ. Assy. Width
	A (mm)	+0.7 -0.3	B ±0.6 (mm)	T ±0.4 (mm)
IL06-030	57.30		78.50	25.40
IL06-030 L	57.30		67.30	25.40
IL06-050	77.30		98.50	25.40
IL06-050 L	77.30		87.30	25.40
IL06-075	102.30		123.50	30.00
IL06-100	127.30		148.50	34.00

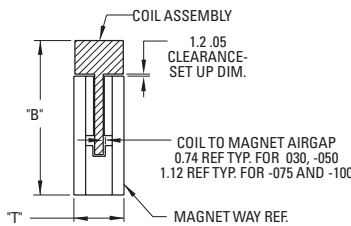

- Notes:
1. Dimensions in mm
  2. Tolerances unless otherwise specified:  
no decimal place ±0.8  
X decimal place ±0.1  
XX decimal place ±0.05

## Termination and Hall Effect Options

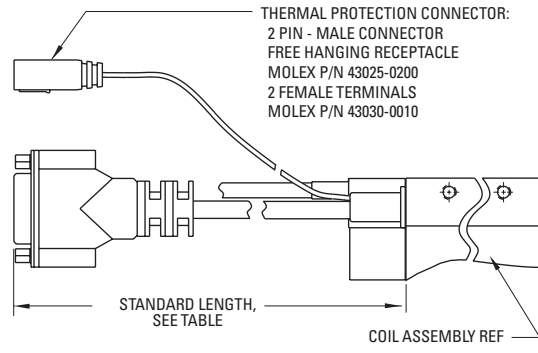
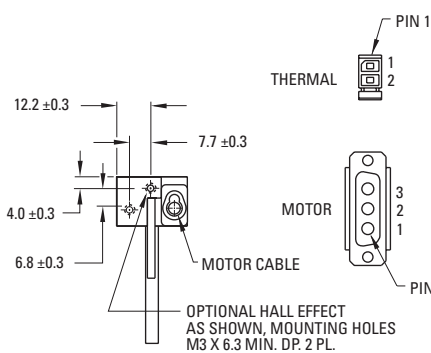

MATING CONNECTOR REFERENCE:  
MOLEX "MICRO-FIT 3.0"  
PLUG: 43020-0201  
MALE TERMINALS: 43031-0010  
SEE WIRE TABLE, PAGE 36

HALL EFFECT CONNECTOR OPTION:  
POSITRONIC P/N: MD9M2000Z  
9 PIN, MALE

MATING CONNECTOR REFERENCE:  
POSITRONIC P/N: MD9F2000X

SEE WIRE TABLE, PAGE 36

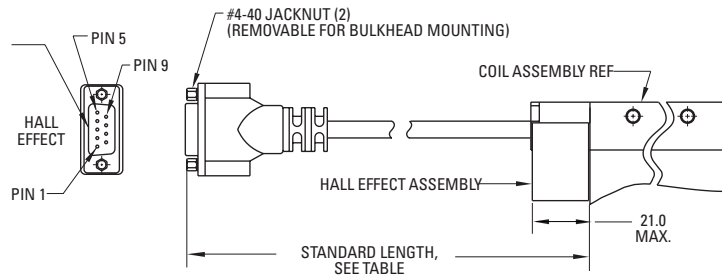

MOTOR CONNECTOR:  
POSITRONIC P/N: CBD3W3M0000Z  
3 PIN MALE, SHELL SIZE 2  
MALE CONTACTS:  
POSITRONIC P/N: MS40--D  
3 REMOVABLE MALE CONTACTS, SIZE 8

MATING CONNECTOR REFERENCE:  
POSITRONIC P/N: CBD3W3F0000X  
3 FEMALE SOCKETS, SOLDER TYPE, SIZE 8, POSITRONIC P/N: FS40--D  
SEE WIRE TABLE, PAGE 36

HALL EFFECT MASS  
W/P\* CONNECTOR: 0.05KG MAX  
W/C\* CABLE: 0.03KG MAX

Connector Option	
Connector	Cable Length (mm)
P1	400
P2	200
P3	100
P4	1200

Flying Lead Option	
Leads	Cable Length (mm)
C1	400
C2	200
C3	100
C4	1200

# IL12 Performance Data

## Ironless Non-Cooled Motors Series

Rated Performance	Symbol	Units	IL12-030			IL12-050			IL12-075			IL12-100	
Peak Force	Fp	N	240			400			600			800	
Continuous Force @ Tmax (1)	Fc	N	62.1			88.4			119			148	
Motor Constant @ 25°C	Km	N/√W	7.8			11.3			14.5			17.2	
Electrical Specifications (2)													
		Winding Code	A1	A2	A4	A1	A2	A4	A1	A2	A4	A2	A4
Peak Current	Ip	Arms	7.1	14.2	28.5	7.0	14.0	28.1	7.0	14.0	28.1	14.0	28.1
Continuous Current @Tmax	Ic	Arms	1.8	3.7	7.4	1.6	3.1	6.2	1.4	2.8	5.6	2.6	5.2
Electrical Resistance @ 25°C±10%	Rm	Ohms L-L	12.2	3.1	0.8	17.2	4.3	1.1	23.3	5.8	1.5	7.4	1.8
Electrical Inductance ±20%	L	mH L-L	2.60	0.65	0.16	6.00	1.5	0.38	10.0	2.5	0.63	3.5	0.88
Back EMF Constant @ 25°C±10%	Ke	Vpeak/m/s L-L	27.5	13.8	6.9	46.5	23.3	11.6	69.8	34.9	17.5	46.5	23.3
Force Constant @ 25°C±10%	Kf	N/Arms	33.7	16.9	8.4	57.0	28.5	14.3	85.5	42.8	21.4	57.0	28.5
Mechanical Specifications													
Coil Assembly Mass ±15%	Mc	kg	0.42			0.52			0.65			0.77	
Magnetic Way Type			MW		MW		MW075		MW100				
			030	030L	050	050L							
Magnetic Way Mass ±15%	Mw	kg/m	9.4	7.3	12.2	10.2	18.9			27.3			
Figures of Merit and Additional Data													
Electrical Time Constant	Te	ms	0.21			0.35			0.43			0.48	
Max.Theoretical Acceleration (3)	Amax	m/s <sup>2</sup>	58.2			78.4			94.1			106	
Magnetic Attraction	Fa	kN	0			0			0			0	
Thermal Resistance (4) (coils to external structure)	Rth	°C/Watt	0.804			0.629			0.519			0.433	
Max. Allowable Coil Temp. (4)	Tmax	°C	130			130			130			130	

**Notes:**

1. The motor continuous rated force is measured with the motor coils achieving the motor maximum allowable temperature Tmax.
2. Alternate windings can be made available. Please consult the Kollmorgen Customer Support for design options.
3. Maximum theoretical acceleration is based on the motors peak force and the motor mass alone. Limitations due to such factors as the additional mass of the load, the bearing type and design, the shock rating of the feedback, the peak current available from the amplifier etc. must be considered to determine the achievable acceleration in each application.
4. Please see our application sizing pages in the back of this guide for more details on sizing and thermal considerations.



# IL12 Outline Drawings

## Ironless Non-Cooled Motors Series

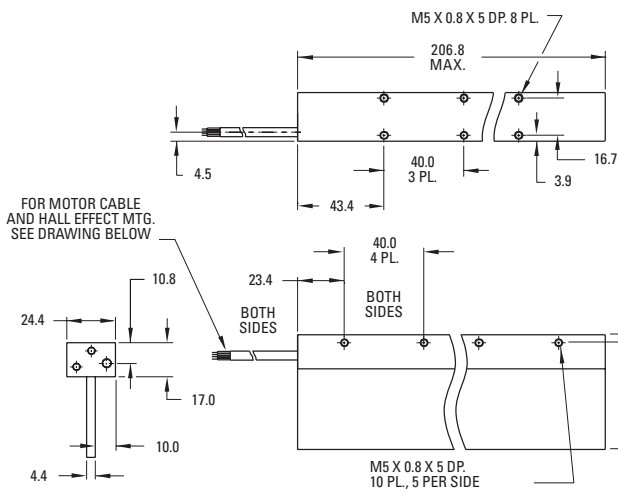

Motor Coil	Coil Width		Typ. Assy. Width	Typ. Assy. Width
	A (mm)	+0.7 -0.3	B ±0.6 (mm)	T ±0.4 (mm)
IL12-030	57.30		78.50	25.40
IL12-030 L	57.30		67.30	25.40
IL12-050	77.30		98.50	25.40
IL12-050 L	77.30		87.30	25.40
IL12-075	102.30		123.50	30.00
IL12-100	127.30		148.50	34.00

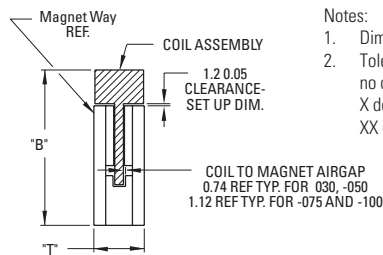

- Notes:
1. Dimensions in mm
  2. Tolerances unless otherwise specified:  
no decimal place ±0.8  
X decimal place ±0.1  
XX decimal place ±0.05

## Termination and Hall Effect Options

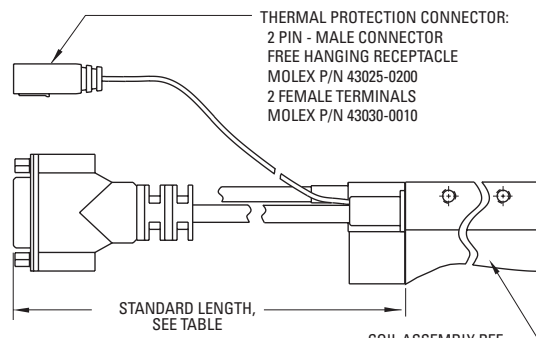
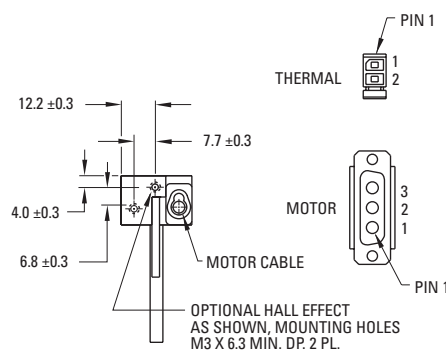

MATING CONNECTOR REFERENCE:  
MOLEX "MICRO-FIT 3.0"  
PLUG: 43020-0201  
MALE TERMINALS: 43031-0010  
SEE WIRE TABLE, PAGE 36

HALL EFFECT CONNECTOR OPTION:  
POSITRONIC P/N: MD9M2000Z  
9 PIN, MALE

MATING CONNECTOR REFERENCE:  
POSITRONIC P/N: MD9F2000X

SEE WIRE TABLE, PAGE 36

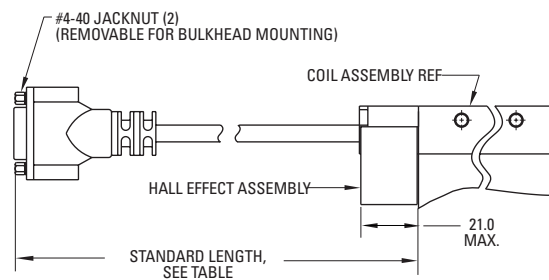
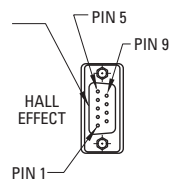

MATING CONNECTOR REFERENCE:  
POSITRONIC P/N: CBD3W3F0000X  
3 FEMALE SOCKETS, SOLDER TYPE,  
SIZE 8, POSITRONIC P/N: FS40--D

SEE WIRE TABLE, PAGE 36

HALL EFFECT MASS  
W/P\* CONNECTOR: 0.05KG MAX  
W/C\* CABLE: 0.03KG MAX

Connector Option	
Connector	Cable Length (mm)
P1	400
P2	200
P3	100
P4	1200

Flying Lead Option	
Leads	Cable Length (mm)
C1	400
C2	200
C3	100
C4	1200

# IL18 Performance Data

## Ironless Non-Cooled Motors Series

Rated Performance	Symbol	Units	IL18-030				IL18-050			
Peak Force	Fp	N	360				600			
Continuous Force @ Tmax (1)	Fc	N	92.1				131			
Motor Constant @ 25°C	Km	N/√W	9.7				13.8			
Electrical Specifications (2)										
		Winding Code	A1	A2	A3	A4	A1	A2	A3	A4
Peak Current	Ip	Arms	7.1	14.3	21.4	42.8	7.0	14.0	21.0	42.1
Continuous Current @Tmax	Ic	Arms	1.8	3.6	5.5	11.0	1.5	3.1	4.6	9.2
Electrical Resistance @ 25°C±10%	Rm	Ohms L-L	18.2	4.6	2.0	0.5	25.7	6.4	2.9	0.7
Electrical Inductance ±20%	L	mH L-L	3.8	0.95	0.42	0.11	9.00	2.25	1.00	0.25
Back EMF Constant @ 25°C±10%	Ke	Vpeak/m/s L-L	41.2	20.6	13.7	6.9	69.8	34.9	23.3	11.6
Force Constant @ 25°C±10%	Kf	N/Arms	50.5	25.3	16.8	8.4	85.5	42.8	28.5	14.3
Mechanical Specifications (2)										
Coil Assembly Mass ±15%	Mc	kg	0.57				0.72			
Magnetic Way Type			MW				MW			
			030	030L	050	050L	050	050L	050	050L
Magnetic Way Mass ±15%	Mw	kg/m	9.4	7.3	12.2	10.2	12.2	10.2	12.2	10.2
Figures of Merit and Additional Data										
Electrical Time Constant	Te	ms	0.21				0.35			
Max.Theoretical Acceleration (3)	Amax	m/s <sup>2</sup>	64.5				84.9			
Magnetic Attraction	Fa	kN	0				0			
Thermal Resistance (4) (coils to external structure)	Rth	°C/Watt	0.536				0.419			
Max. Allowable Coil Temp. (4)	Tmax	°C	130				130			

Notes:

1. The motor continuous rated force is measured with the motor coils achieving the motor maximum allowable temperature Tmax.
2. Alternate windings can be made available. Please consult the Kollmorgen Customer Support for design options.
3. Maximum theoretical acceleration is based on the motors peak force and the motor mass alone. Limitations due to such factors as the additional mass of the load, the bearing type and design, the shock rating of the feedback, the peak current available from the amplifier etc. must be considered to determine the achievable acceleration in each application.
4. Please see our application sizing pages in the back of this guide for more details on sizing and thermal considerations.

Rated Performance	Symbol	Units	IL18-075				IL18-100			
Peak Force	Fp	N	900				1200			
Continuous Force @ Tmax (1)	Fc	N	173				211			
Motor Constant @ 25°C	Km	N√W	17.7				21.0			
Electrical Specifications (2)										
		Winding Code	A1	A2	A3	A4	A1	A2	A3	A4
Peak Current	Ip	Arms	7.0	14.0	21.0	42.1	7.0	14.0	21.0	42.1
Continuous Current @Tmax	Ic	Arms	1.4	2.7	4.0	8.1	1.2	2.5	3.7	7.4
Electrical Resistance @ 25°C±10%	Rm	Ohms L-L	35.0	8.8	3.9	1.0	44.2	11.1	4.9	1.2
Electrical Inductance ±20%	L	mH L-L	15.0	3.75	1.67	0.42	21.0	5.25	2.33	0.58
Back EMF Constant @ 25°C±10%	Ke	Vpeak/m/s L-L	105	52.4	34.9	17.5	140	69.9	46.6	23.3
Force Constant @ 25°C±10%	Kf	N/Arms	128	64.2	42.8	21.4	171	85.6	57.0	28.5
Mechanical Specifications										
Coil Assembly Mass ±15%	Mc	kg	0.91				1.10			
<b>Magnetic Way Type</b>			<b>MW075</b>				<b>MW100</b>			
<b>Magnetic Way Mass ±15%</b>	Mw	kg/m	18.9				27.3			
Figures of Merit and Additional Data										
Electrical Time Constant	Te	ms	0.43				0.48			
Max.Theoretical Acceleration (3)	Amax	m/s <sup>2</sup>	101				111			
Magnetic Attraction	Fa	kN	0				0			
Thermal Resistance (4) (coils to external structure)	Rth	°C/Watt	0.35				0.29			
Max. Allowable Coil Temp. (4)	Tmax	°C	130				130			

**Notes:**

1. The motor continuous rated force is measured with the motor coils achieving the motor maximum allowable temperature Tmax.
2. Alternate windings can be made available. Please consult the Kollmorgen Customer Support for design options.
3. Maximum theoretical acceleration is based on the motors peak force and the motor mass alone. Limitations due to such factors as the additional mass of the load, the bearing type and design, the shock rating of the feedback, the peak current available from the amplifier etc. must be considered to determine the achievable acceleration in each application.
4. Please see our application sizing pages in the back of this guide for more details on sizing and thermal considerations.

# IL18 Outline Drawings

## Ironless Non-Cooled Motors Series

Motor Coil	Coil Width		Typ. Assy. Width	Typ. Assy. Width
	A (mm)	+0.7 -0.3	B ±0.6 (mm)	T ±0.4 (mm)
IL18-030	57.30		78.50	25.40
IL18-030 L	57.30		67.30	25.40
IL18-050	77.30		98.50	25.40
IL18-050 L	77.30		87.30	25.40
IL18-075	102.30		123.50	30.00
IL18-100	127.30		148.50	34.00

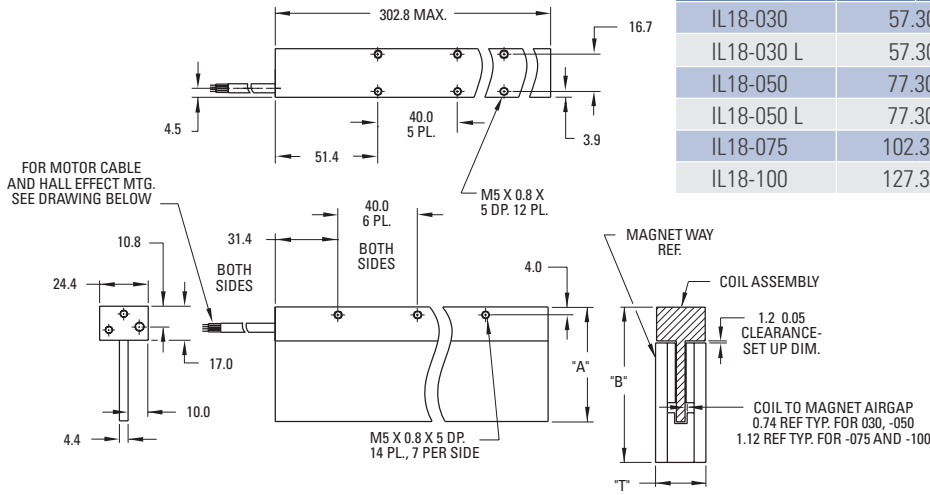

- Notes:
- Dimensions in mm
  - Tolerances unless otherwise specified:
    - no decimal place ±0.8
    - X decimal place ±0.1
    - XX decimal place ±0.05

## Termination and Hall Effect Options

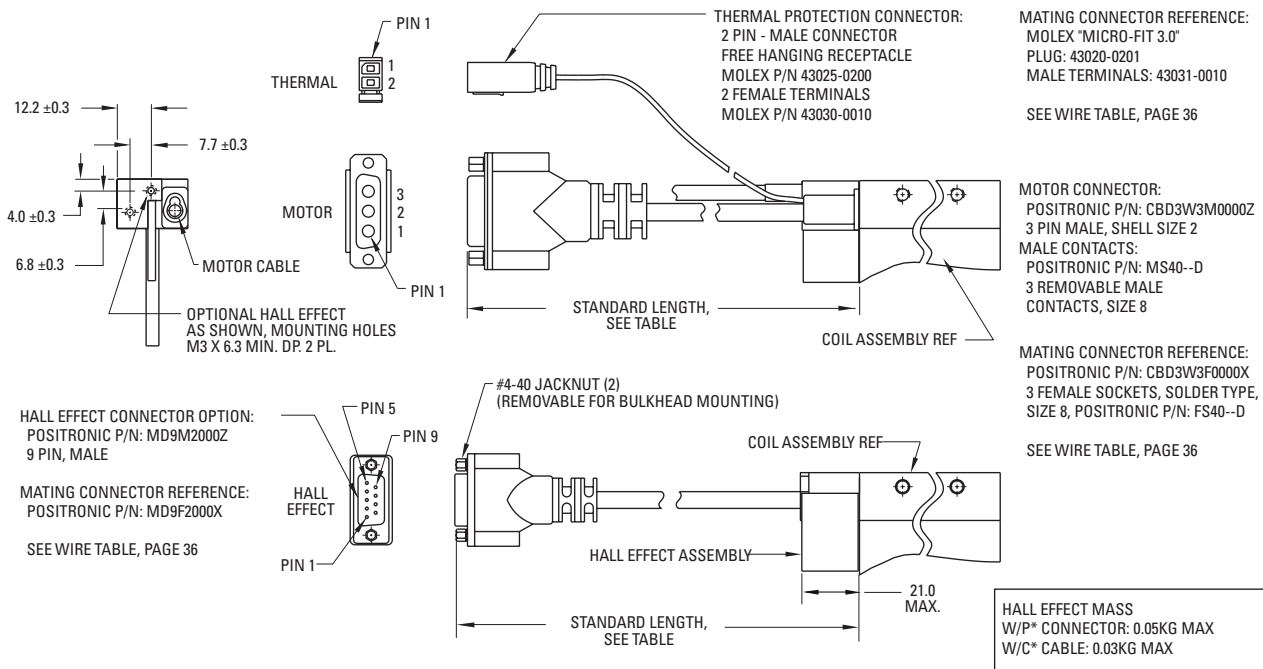

Connector Option	
Connector	Length (mm)
P1	400
P2	200
P3	100
P4	1200

Flying Lead Option	
Leads	Length (mm)
C1	400
C2	200
C3	100
C4	1200

# Notes

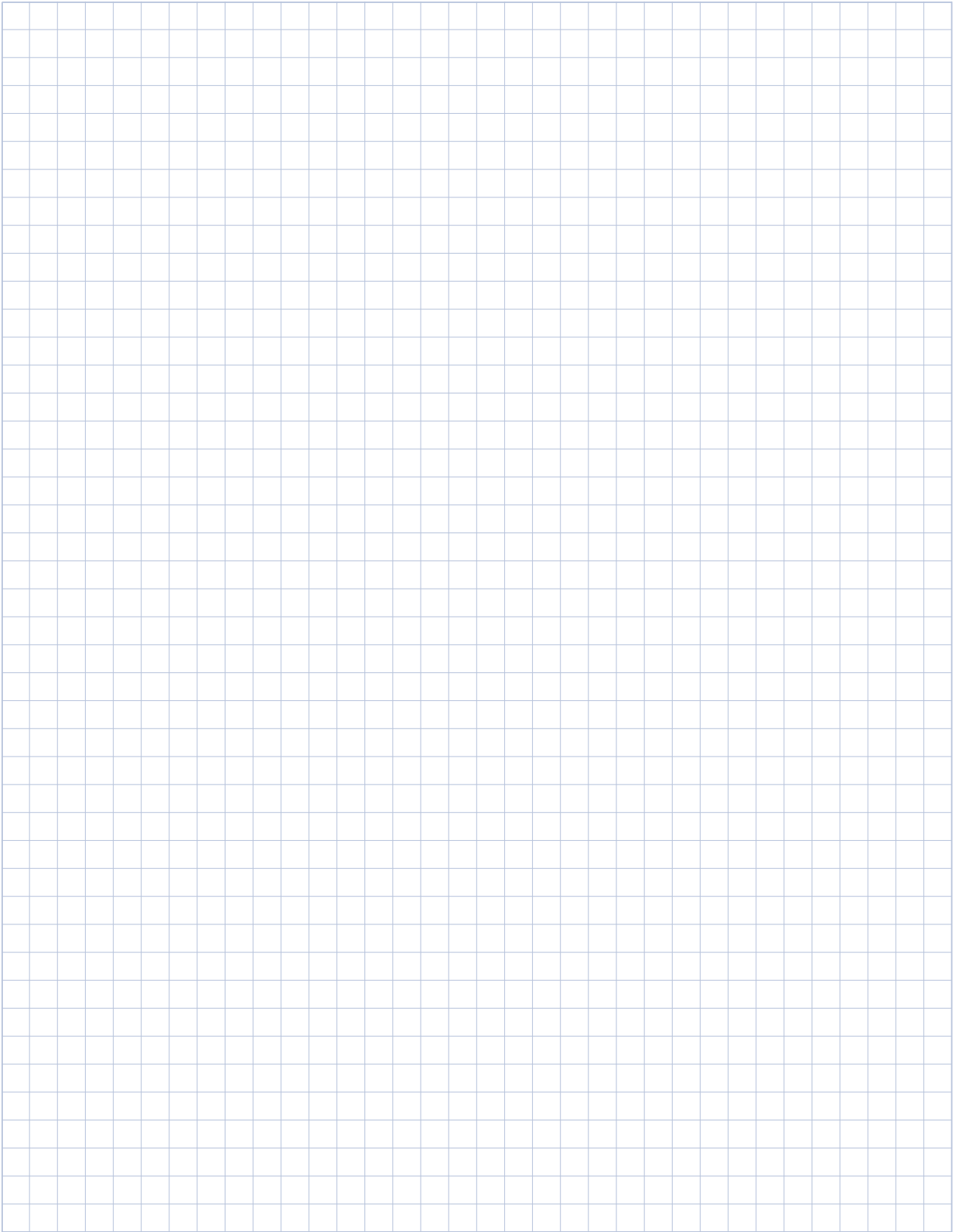

# IL24 Performance Data

## Ironless Non-Cooled Motors Series

Rated Performance	Symbol	Units	IL24-030			IL24-050			IL24-075				IL24-100			
Peak Force	Fp	N	480			800			1200				1600			
Continuous Force @ Tmax (1)	Fc	N	109			155			211				262			
Motor Constant @ 25°C	Km	N/√W	11.2			15.9			20.6				24.4			
Electrical Specifications (2)																
		Winding Code	A1	A2	A3	A1	A2	A3	A1	A2	A3	A4	A1	A2	A3	A4
Peak Current	Ip	Arms	7.1	14.2	28.5	7.0	14.0	28.1	7.0	14.0	28.0	56.1	7.0	14.0	28.1	56.1
Continuous Current @Tmax	Ic	Arms	1.6	3.2	6.4	1.4	2.7	5.4	1.2	2.5	4.9	9.9	1.2	2.3	4.6	9.2
Electrical Resistance @ 25°C±10%	Rm	Ohms L-L	24.3	6.1	1.5	34.3	8.6	2.1	46.6	11.7	2.9	0.73	58.9	14.7	3.7	0.92
Electrical Inductance ±20%	L	mH L-L	5.1	1.28	0.32	12.0	3.00	0.75	20.0	5.0	1.25	0.31	28.0	7.00	1.75	0.44
Back EMF Constant @ 25°C±10%	Ke	Vpeak/m/s L-L	55.0	27.5	13.8	93.1	46.5	23.3	140.	69.9	34.9	17.5	186	93.1	46.6	23.3
Force Constant @ 25°C±10%	Kf	N/Arms	67.4	33.7	16.9	114	57.0	28.5	171	85.6	42.8	21.4	228	114	57.0	28.5
		lbf/Arms	15.2	7.6	3.8	25.6	12.8	6.4	38.5	19.2	9.6	4.8	51.3	25.6	12.8	6.4
Mechanical Specifications																
Coil Assembly Mass ±15%	Mc	kg	0.72			0.92			1.17				1.42			
Magnetic Way Type			MW			MW			MW				MW			
			030	030L	050	050L	075				100					
Magnetic Way Mass ±15%	Mw	kg/m	9.4	7.3	12.2	10.2	18.9				27.3					
Figures of Merit and Additional Data																
Electrical Time Constant	Te	ms	0.21			0.35			0.43				0.48			
Max.Theoretical Acceleration(3)	Amax	m/s <sup>2</sup>	68.0			88.7			105				115			
Magnetic Attraction	Fa	kN	0			0			0				0			
Thermal Resistance (4) (coils to external structure)	Rth	°C/Watt	0.40			0.32			0.26				0.22			
Max. Allowable Coil Temp. (4)	Tmax	°C	130			130			130				130			

**Notes:**

1. The motor continuous rated force is measured with the motor coils achieving the motor maximum allowable temperature Tmax.
2. Alternate windings can be made available. Please consult the Kollmorgen Customer Support for design options.
3. Maximum theoretical acceleration is based on the motors peak force and the motor mass alone, Limitations due to such factors as the additional mass of the load, the bearing type and design, the shock rating of the feedback, the peak current available from the amplifier etc. must be considered to determine the achievable acceleration in each application.
4. Please see our application sizing pages in the back of this guide for more details on sizing and thermal considerations.

# IL24 Outline Drawings

## Ironless Non-Cooled Motors Series

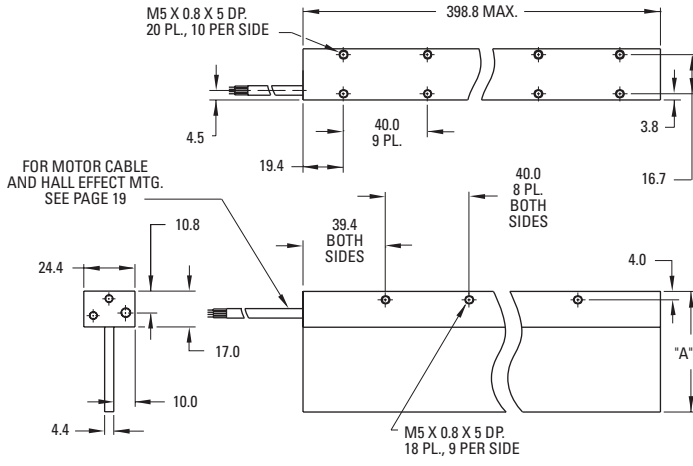

Motor Coil	Coil Width		Typ. Assy. Width	Typ. Assy. Width
	A (mm)	+0.7 -0.3	B ±0.6 (mm)	T ±0.4 (mm)
IL24-030	57.30		78.50	25.40
IL24-030 L	57.30		67.30	25.40
IL24-050	77.30		98.50	25.40
IL24-050 L	77.30		87.30	25.40
IL24-075	102.30		123.50	30.00
IL24-100	127.30		148.50	34.00

- Notes:
- Dimensions in mm
  - Tolerances unless otherwise specified:  
no decimal place ±0.8  
X decimal place ±0.1  
XX decimal place ±0.05

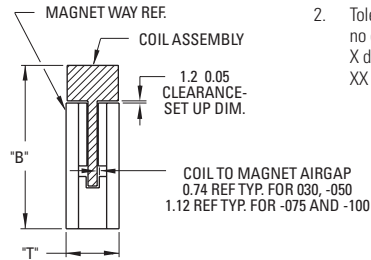

## Termination and Hall Effect Options

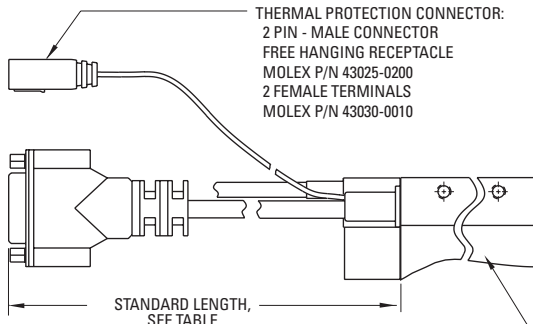
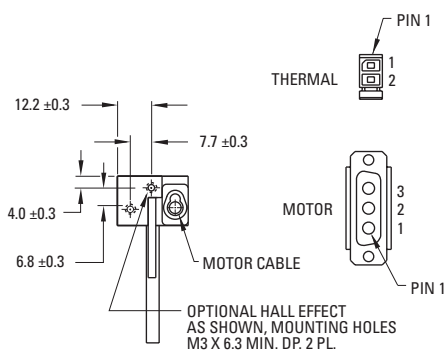

HALL EFFECT CONNECTOR OPTION:  
POSITRONIC P/N: MD9M2000Z  
9 PIN, MALE

MATING CONNECTOR REFERENCE:  
POSITRONIC P/N: MD9F2000X

SEE WIRE TABLE, PAGE 36

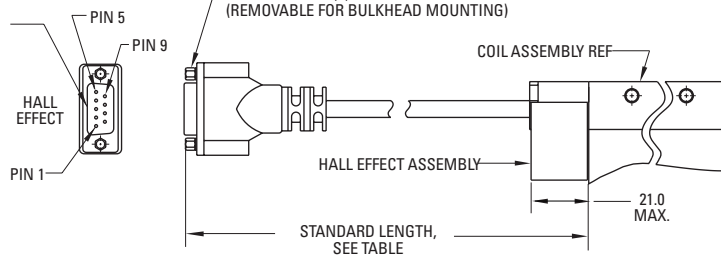

HALL EFFECT MASS  
W/P\* CONNECTOR: 0.05KG MAX  
W/C\* CABLE: 0.03KG MAX

Connector Option	
Connector	Cable Length (mm)
P1	400
P2	200
P3	100
P4	1200

Flying Lead Option	
Leads	Cable Length (mm)
C1	400
C2	200
C3	100
C4	1200

# Ironless Magnet Ways

## MWxxx-0064

Magnet assemblies are modular and can be installed in multiples of same or alternate lengths (see page 34). Standard assembly lengths are shown below.

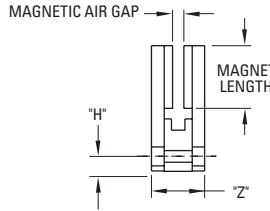
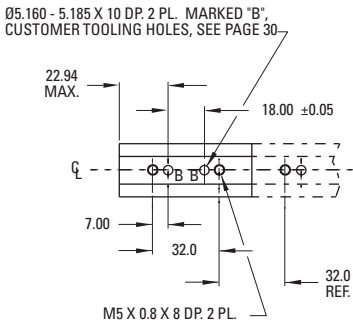
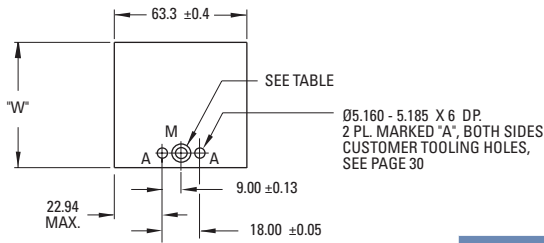

- Notes:
1. Dimensions in mm
  2. Tolerances unless otherwise specified:  
no decimal place  $\pm 0.8$   
X decimal place  $\pm 0.1$   
XX decimal place  $\pm 0.05$

Magnet Way	Magnet Size Ref.	H $\pm 0.8$	W $\pm 0.4$	Z $\pm 0.4$
MW030-0064	30 mm	7.11	60.20	25.40
MW030L-0064	30 mm	5.69	49.00	25.40
MW050-0064	50 mm	7.11	80.20	25.40
MW050L-0064	50 mm	5.69	69.00	25.40
MW075-0064	75 mm	8.23	105.20	30.00
MW100-0064	100 mm	8.23	130.20	34.00

Magnet Way	Hardware (Hex. Socket Head Cap)					
	Hole Dia. $\pm 0.13$	C'bore Dia. $\pm 0.13$	Cbore Depth $\pm 0.13$	Metric	Inch	Bottom Mount Thread Option
MW030-0064	5.70	9.35	5.79	M5	#10	M5 X 0.8 X 8.0 DP.
MW030L-0064	4.70	7.80	5.79	M4	#8	M4 X 0.7 X 6.0 DP.
MW050-0064	5.70	9.35	5.79	M5	#10	M5 X 0.8 X 8.0 DP.
MW050L-0064	4.70	7.80	5.79	M4	#8	M4 X 0.7 X 6.0 DP.
MW075-0064	5.70	9.35	7.95	M5	#10	M5 X 0.8 X 8.0 DP.
MW100-0064	5.70	9.35	9.96	M5	#10	M5 X 0.8 X 8.0 DP.

## MWxxx-0128

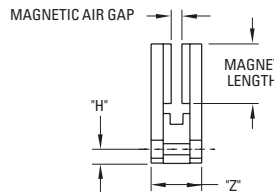
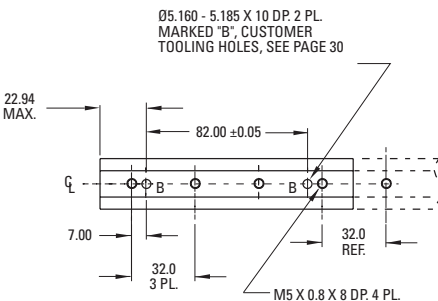
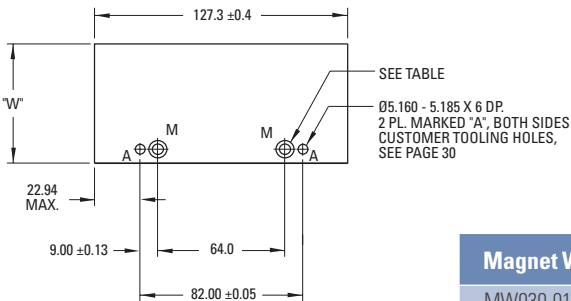

Magnet Way	Magnet Size Ref.	H $\pm 0.8$	W $\pm 0.4$	Z $\pm 0.4$
MW030-0128	30 mm	7.11	60.20	25.40
MW030L-0128	30 mm	5.69	49.00	25.40
MW050-0128	50 mm	7.11	80.20	25.40
MW050L-0128	50 mm	5.69	69.00	25.40
MW075-0128	75 mm	8.23	105.20	30.00
MW100-0128	100 mm	8.23	130.20	34.00

Magnet Way	Hardware (Hex. Socket Head Cap)					
	Hole Dia. $\pm 0.13$	C'bore Dia. $\pm 0.13$	Cbore Depth $\pm 0.13$	Metric	Inch	Bottom Mount Thread Option
MW030-0128	5.70	9.35	5.79	M5	#10	M5 X 0.8 X 8.0 DP.
MW030L-0128	4.70	7.80	5.79	M4	#8	M4 X 0.7 X 6.0 DP.
MW050-0128	5.70	9.35	5.79	M5	#10	M5 X 0.8 X 8.0 DP.
MW050L-0128	4.70	7.80	5.79	M4	#8	M4 X 0.7 X 6.0 DP.
MW075-0128	5.70	9.35	7.95	M5	#10	M5 X 0.8 X 8.0 DP.
MW100-0128	5.70	9.35	9.96	M5	#10	M5 X 0.8 X 8.0 DP.



## MWxxx-0256

Magnet assemblies are modular and can be installed in multiples of same or alternate lengths (see page 32). Standard assembly lengths are shown below.

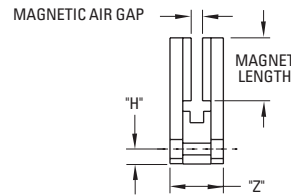
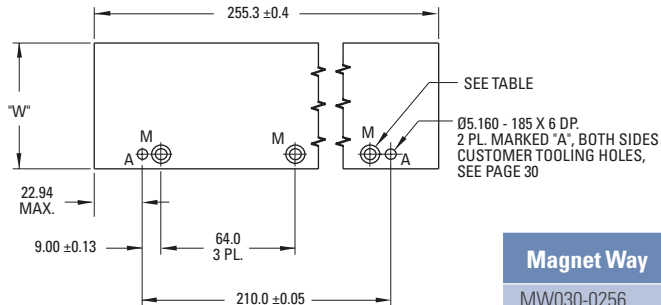

- Notes:
1. Dimensions in mm (inches)
  2. Tolerances unless otherwise specified:  
no decimal place  $\pm 0.8$  (0.3)  
X decimal place  $\pm 0.1$  (.004)  
XX decimal place  $\pm 0.05$  (0.002)

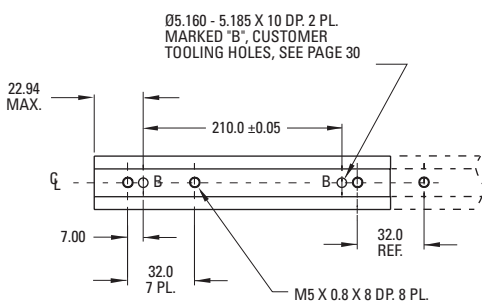

Magnet Way	Magnet Size Ref.	H $\pm 0.8$	W $\pm 0.4$	Z $\pm 0.4$
MW030-0256	30 mm	7.11	60.20	25.40
MW030L-0256	30 mm	5.69	49.00	25.40
MW050-0256	50 mm	7.11	80.20	25.40
MW050L-0256	50 mm	5.69	69.00	25.40
MW075-0256	75 mm	8.23	105.20	30.00
MW100-0256	100 mm	8.23	130.20	34.00

Magnet Way	Hardware (Hex. Socket Head Cap)					
	Hole Dia. $\pm 0.13$	C'bore Dia. $\pm 0.13$	Cbore Depth $\pm 0.13$	Metric	Inch	Bottom Mount Thread Option
MW030-0512	5.70	9.35	5.79	M5	#10	M5 X 0.8 X 8.0 DP.
MW030L-0512	4.70	7.80	5.79	M4	#8	M4 X 0.7 X 6.0 DP.
MW050-0512	5.70	9.35	5.79	M5	#10	M5 X 0.8 X 8.0 DP.
MW050L-0512	4.70	7.80	5.79	M4	#8	M4 X 0.7 X 6.0 DP.
MW075-0512	5.70	9.35	7.95	M5	#10	M5 X 0.8 X 8.0 DP.
MW100-0512	5.70	9.35	9.96	M5	#10	M5 X 0.8 X 8.0 DP.

## MWxxx-0512

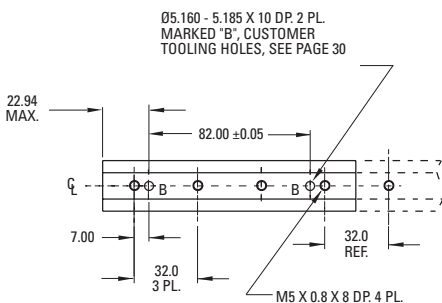
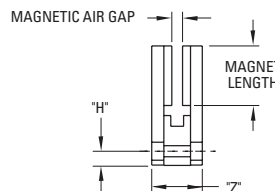
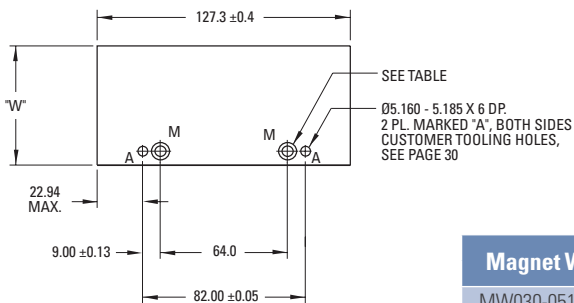

Magnet Way	Magnet Size Ref.	H $\pm 0.8$	W $\pm 0.4$	Z $\pm 0.4$
MW030-0512	30 mm	7.11	60.20	25.40
MW030L-0512	30 mm	5.69	49.00	25.40
MW050-0512	50 mm	7.11	80.20	25.40
MW050L-0512	50 mm	5.69	69.00	25.40
MW075-0512	75 mm	8.23	105.20	30.00
MW100-0512	100 mm	8.23	130.20	34.00

Magnet Way	Hardware (Hex. Socket Head Cap)					
	Hole Dia. $\pm 0.13$	C'bore Dia. $\pm 0.13$	Cbore Depth $\pm 0.13$	Metric	Inch	Bottom Mount Thread Option
MW030-0512	5.70	9.35	5.79	M5	#10	M5 X 0.8 X 8.0 DP.
MW030L-0512	4.70	7.80	5.79	M4	#8	M4 X 0.7 X 6.0 DP.
MW050-0512	5.70	9.35	5.79	M5	#10	M5 X 0.8 X 8.0 DP.
MW050L-0512	4.70	7.80	5.79	M4	#8	M4 X 0.7 X 6.0 DP.
MW075-0512	5.70	9.35	7.95	M5	#10	M5 X 0.8 X 8.0 DP.
MW100-0512	5.70	9.35	9.96	M5	#10	M5 X 0.8 X 8.0 DP.

# Ironless Magnet Ways

Magnet Way widths correspond to the mating coil assembly width.

Magnet Way assemblies are modular and come in standard lengths: 64. 128. 256. 512 mm.

## Bottom Mounting Installation

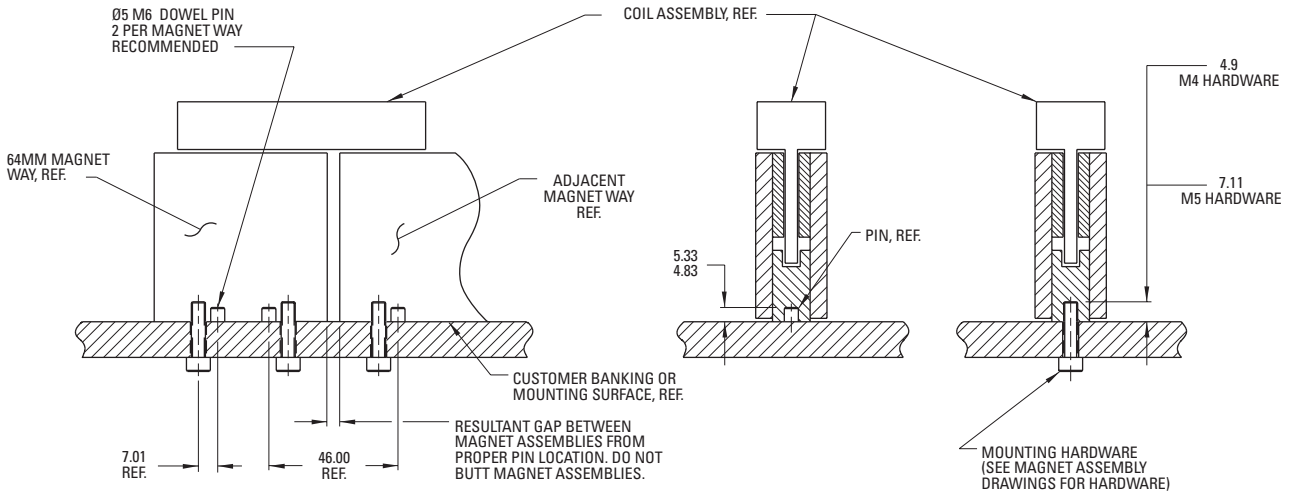

Dimensions in mm

## Side mounting installation

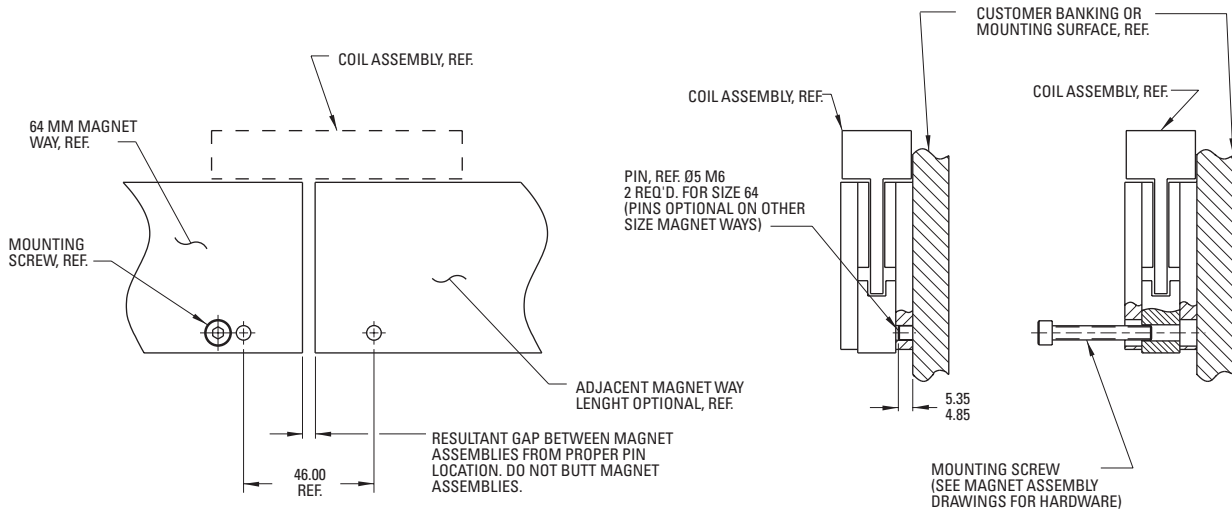

Dimensions in mm

# Notes

A large grid of graph paper for taking notes, consisting of 20 columns and 30 rows of small squares.

# Wiring and Output

## Ironcore Non-Cooled Motors ICH-Series

### Motor Wire Table

See the cable data on pages 13, 15, 17, 19

	Cable	Plug BKUA Option <sup>1)</sup>
U	Black U	1
V	Black V	3
W	Black W	4
PE	Green /Yellow	PE
PTC1	Black 5	A
PTC2	Black 6	B
KTY+	Black 7	C
KTY-	Black 8	D

Note 1: For motors with  $I_c < 15$  A

### Hall Effect Wire Table

Ø 4.6 mm

Pin Number	Color	Function
1	Gray	+5 VDC
2	Green	S1
3	Yellow	S2
4	Brown	S3
5	White	Return
Shell	Shield	Shield

## Ironless Non-Cooled Motors IL-Series

### Motor Wire Table

A1, A2, A3, A4: 18 AWG, Ø5.6 mm

Pin Number	Color	Function
1	Red	A
2	White	B
3	Black	C
Connector Shell	Green /Yellow	GND
Connector Shell	Violet	Shield

### Hall Effect Wire Table

26 AWG, Ø6.0 mm

Pin Number	Color	Function
1	Gray	+5 VDC
2	Green	S1
3	Yellow	S2
4	Brown	S3
5	White	Return
Shell	Shield	Shield

### Thermal Protection Wire Table

26 AWG, Ø3.8 mm

Pin	Color	Transition Point
1	Black /White	130°C
2	Black /White	130°C

Note: TIC-X extender cable is shielded

## Ironcore and Ironless Motors Output Diagrams

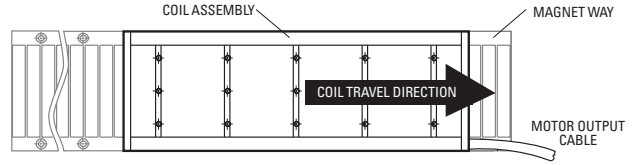
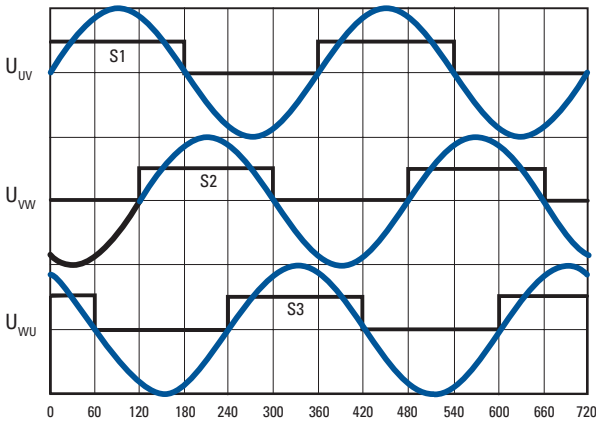

Magnet pole pitch:  
Both Ironcore (ICH) and Ironless (IL) feature the same pole pitch, which is 32 mm (360 electrical degrees).

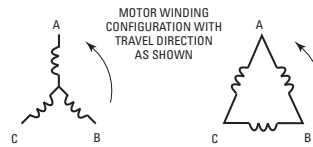

Motor BEMF phases U, V, W relative to Hall effect devices S1,S2,S3 with coil travel direction towards the motor output cable assembly exit as shown on the right hand side

Note:

- The diagram above refers to both ironless (IL) and ironcore (ICH) motors

## Mounting of Hall Sensor on ICH Ironcore Motors

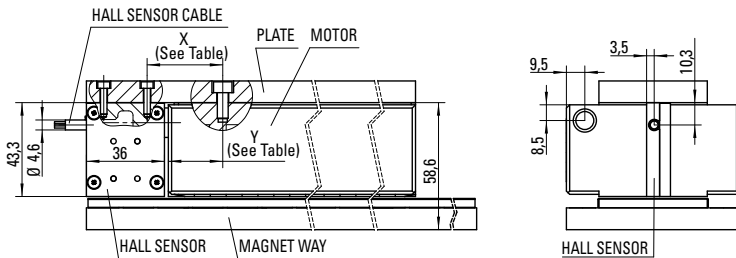

Hall Sensor Mounting Distance X

ICH Type	X (mm)	Y (mm)
ICH11	34.9	25.1
ICH22	48.9	38.1
ICH33	60.9	51.1
ICH44	36.4	26.6

Dimensions Hall Sensor HD-Y-Px or HD-D-Px (mm)

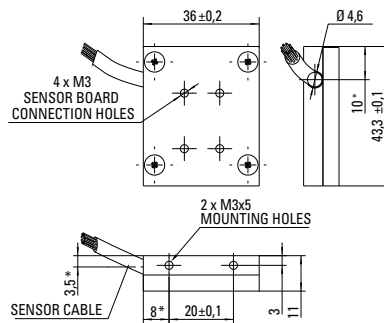
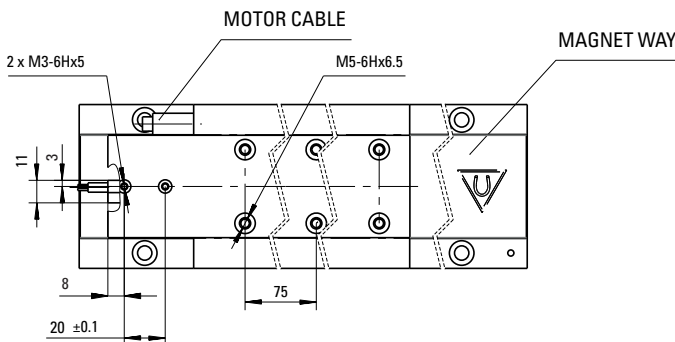

\* - for reference only

# Application Sizing

## To size a Linear Motor, you will need to:

1. Define a Move Profile
2. Define the Load
3. Size the Motor and the Amplifier

From the move profile, we can calculate the maximum speed and the maximum acceleration/deceleration. From the load we can calculate all of the forces at constant speed and using the move profile all the dynamic forces during acceleration and deceleration. Once a motor is selected, the weight of the moving parts of the motor are added to the moving weight to calculate a total Peak Force and a total RMS force. The motor should be able to deliver the peak force and the calculated RMS force should be less than the motor continuous force to ensure a known safety margin. The coil temperature rise can also be calculated to ensure that it is lower than the intended maximum temperature rise.

The maximum bus voltage and continuous and peak current can also be calculated and compared to the selected amplifier to be sure the calculated performances can be achieved.

## 1. Move Profile

### Triangular/Trapezoidal

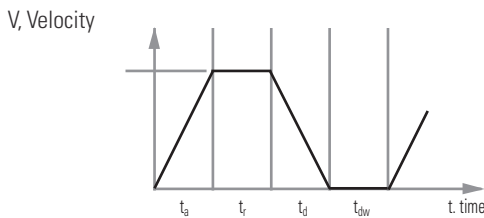

Units  
**SI**

$S_m$ - Move displacement	meters
$t_a$ - Acceleration Time	seconds
$t_r$ - Time run at constant speed	seconds
$t_d$ - Deceleration Time	seconds
$t_{dw}$ - Dwell Time	seconds
$V_m$ - Max Velocity	meter
$A_m$ - Acceleration	meter/sec <sup>2</sup>
$D_m$ - Deceleration	meter/sec <sup>2</sup>

## Example:

Move 0.1 meter in 100 msec assuming  $t_a = t_d$  and  $t_r = 0$ .  
(assume triangular move)

**Max Speed:**

$$V_m = 2 \cdot S_m / (t_a + t_d + 2 \cdot t_r)$$

$$V_m = 2 \cdot 0.1 / (100E-3) \text{ m/s}$$

$$= 2 \text{ m/s}$$

## Max Acceleration/Deceleration

Acceleration

$$A_m = V_m / t_a$$

$$A_m = 2 / 50E-3 \text{ m/s}^2$$

$$= 40 \text{ m/s}^2$$

$$A_m \text{ "g"} = A_m / 9.81 \text{ m/s}^2$$

$$a \text{ (g)} = 40 / 9.81$$

$$= 4.08 \text{ g}$$

Deceleration

$$D_m = V_m / t_d$$

$$D_m = 2 / 50E-3 \text{ m/s}^2$$

$$= 40 \text{ m/s}^2$$

$$Dm \text{ "g"} = Dm / 9.81 \text{ m/s}^2$$

$$d \text{ (g)} = 40 / 9.81$$

$$= 4.08 \text{ g}$$

## 2. Load

Units  
**SI**

$F_{ext}$ - External Force only (Cutting force, etc.)	N
$F_{acc}$ - Acceleration Force only	N
$F_r$ - Run Force at constant speed	N
$F_{dec}$ - Deceleration Force only	N
$F_{am}$ - Max. Acceleration Force	N
$F_{dm}$ - Max. Deceleration Force	N
$F_{dw}$ - Dwell Force	N
$F_{rms}$ - RMS Force	N
$\omega$ - Coefficient of Friction (bearing support)	-
$M_l$ - Load Mass	kg
$M_c$ - Coil Mass	kg
$M_{cb}$ - Counterbalance Mass	kg
$F_a$ - Magnetic Attraction Force	N
CB - Counterbalance of load in %	-
$q$ - Angle of Linear Displacement with horizontal (0°= horizontal, 90° vertical)	degrees
$g$ - Gravity coefficient	9.81 m/s <sup>2</sup>
$n$ - Number of motors in parallel	-

## BASIC FORMULAS\*:

We assume a general case where we have n motors solidly coupled pushing the load and a possible counterbalance weight M<sub>cb</sub> (Mostly for vertical displacement).

### Example of Coefficient of Friction μ:

Linear bearing w/ balls	0.002 - 0.004
Linear bearing w/ rollers	0.005
Steel on oiled steel	0.06
Steel on dry steel	0.2
Steel on concrete	0.3

### Counterbalance Weight:

$$M_{cb} = MI \cdot CB/100$$

### Acceleration Force only:

$$F_{acc} = [(M_l/n) \cdot (1 + CB/100) + M_c] \cdot A_m$$

### Run Force at constant speed:

$$F_r = (M_l/n + M_c) \cdot g \cdot \sin(q) + m \cdot \cos(q) - (M_{cb}/n) \cdot g + F_a \cdot \mu + F_{ext}/n$$

### Deceleration Force only:

$$F_{dec} = [(M_l/n) \cdot (1 + CB/100) + M_c] \cdot D_m$$

### Maximum Acceleration Force:

$$F_{am} = F_{acc} + F_r$$

### Maximum Deceleration Force:

$$F_{dm} = F_{dec} - F_r$$

### Dwell Force:

$$F_{dw} = (M_l/n + M_c) \cdot g \cdot [\sin(q)] - (M_{cb}/n) \cdot g$$

RMS Force:

$$F_{rms} = \sqrt{\frac{F_{am}^2 \cdot t_a + F_r^2 \cdot t_r + F_{dm}^2 \cdot t_d + F_{dw}^2 \cdot t_{dw}}{t_a + t_r + t_d + t_{dw}}}$$

\* All calculations are given in SI units

## 3. SIZE THE MOTOR AND AMPLIFIER

### Example:

Moving Weight:	MI = 0.5 kg
Number of Motors:	n = 1
Horizontal Move:	q = 0
Counterbalance Force:	M <sub>cb</sub> = 0
External Force:	F <sub>ext</sub> = 0
Friction Coefficient:	m = 0.01

Assume same move as above with a Dwell Time of 50 ms.

$$\text{Run Force at Constant Speed: } F_r = 0.5 \cdot 9.81 \cdot 0.01 = 0.05 \text{ N}$$

$$\text{Acceleration Force only: } F_a = 0.5 \cdot 40 = 20 \text{ N}$$

$$\text{Deceleration Force only: } F_d = 0.5 \cdot 40 = 20 \text{ N}$$

$$\text{Maximum Accel Force: } F_{am} = 20 + 0.05 = 20.05 \text{ N}$$

$$\text{Maximum Decel Force: } F_{dm} = 20 - 0.05 = 19.95 \text{ N}$$

Rms Force:

$$F_{rms} = \sqrt{\frac{(20.05)^2 \cdot (50E-3) + (19.95)^2 \cdot (50E-3)}{100E-3 + 50E-3}}$$

$$F_{rms} = 16.3 \text{ N}$$

### Motor Sizing:

If we select an ironless motor for smoothest possible move we can use Motor IL060-30A1. This motor has a coil mass of 0.21 kg and no attractive force. By adding that weight in equations above, we need an additional force of  $0.21 \cdot 40 \cdot 0.01 = 0.084 \text{ N}$ .

So peak force is  $20.05 + 0.08 = 28.45 \text{ N}$  and RMS force is  $23.19 \text{ N}$ . This motor will have a safety factor of  $(38-23.19) \cdot 100/38 = 39\%$ .

### Sizing the Amplifier :

	SI Units
I <sub>a</sub> - Max Acceleration Current	A
I <sub>r</sub> - Run Current	A
I <sub>d</sub> - Max Deceleration Current	A
I <sub>dw</sub> - Dwell Current	A
I <sub>rms</sub> - RMS Current	A
K <sub>f</sub> - Force Constant	N/A
R <sub>m</sub> - Motor Electrical Resistance	Ohms L-L
K <sub>e</sub> - Back EMF Constant	Vpeak/m/s
V <sub>bus</sub> - Bus Voltage	V DC
L - Electrical Inductance	H L-L

$$\text{Max Acceleration Current: } I_a = F_{am}/K_f$$

$$\text{Run Current at constant Speed: } I_r = F_r/K_f$$

$$\text{Max Deceleration Current only: } I_d = F_{dm}/K_f$$

$$\text{Dwell Current: } I_{dw} = F_{dw}/K_f$$

$$\text{RMS Current: } I_{rms} = F_{rms}/K_f$$

# Application Sizing

## BUS VOLTAGE:

If we assume a sine wave drive with a phase advance  $\varphi$  (degrees) and full conduction, the minimum bus voltage (see Fig. 1) is:

$$V_{b1} = 2.4 \text{ V}$$

$$V_{b2} = K_e \cdot V_m$$

$$V_{b3} = \frac{\sqrt{3}}{\sqrt{2}} \cdot R_{m,hot} \cdot I_{rms}$$

$$V_{b4} = 2\pi \frac{\sqrt{3}}{\sqrt{2}} \cdot L \cdot I_{rms} \cdot V_m / \text{Pitch}$$

$$a_v = \arctan(V_{b4}/V_{b3})$$

$$V_{lr} = \sqrt{V_{b3}^2 + V_{b4}^2}$$

$$V_{bre} = V_{b2} + V_{lr} \cdot \cos(a_v + \varphi)$$

$$V_{bim} = V_{lr} \cdot \sin(a_v + \varphi)$$

$$V_{bus} = V_{b1} + \sqrt{V_{bre}^2 + V_{bim}^2}$$

Note: If there is no phase advance take  $\varphi = 0^\circ$

Figure 1:

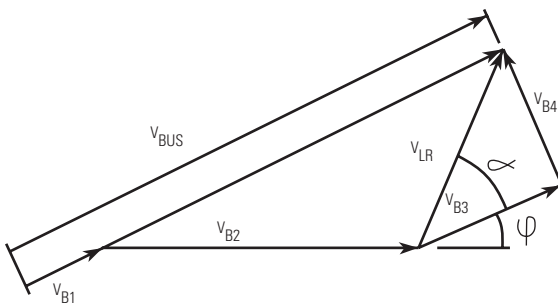

## THERMAL CONSIDERATIONS:

	Units
$\Delta\theta$ - Coil increase of temperature	$^\circ\text{C}$
$R_{th}$ - Thermal Resistance	$^\circ\text{C}/\text{W}$
$K_m$ - Motor Constant	$\text{N}/\sqrt{\text{W}}$
$P_{out}$ - Output Power	$\text{W}$

### Coil Temperature rise

$$\Delta\theta = R_{th} \cdot (F_{rms}/K_m)^2$$

### Resistance of Coil hot (copper)

$$R_{m,hot} = \frac{R_{ambient} (234.5 + \theta_{hot})}{(234.5 + \theta_{amb})}$$

### Power Losses

$$P_{lrms} = \Delta\theta / R_{th} = \frac{(\theta_{hot} - \theta_{ambient})}{R_{th}}$$

### Output Power

$$P_{out(max)} = F_{am} \cdot V_m$$

### Example: In above example with:

$$R_{th} = 1.61 \text{ } ^\circ\text{C}/\text{W}$$

$$K_m = 4.7 \text{ N}/\sqrt{\text{W}}$$

### Coil Temperature rise:

$$\Delta\theta = 1.61 \cdot (23.19/4.7)^2 = 39.2^\circ\text{C}$$

$$\text{Power losses } P_l = 39.2 / 1.61 = 24.34 \text{ Watts}$$

$$\text{Max output Power } P_{out(max)} = 57 \text{ Watts}$$

### The Use of the Motor Constant K:

Cognizance of the heat load being generated by the linear motor is an important consideration in the application of any linear motor. Linear motors are direct drive devices, typically mounted very close to the moving load. Therefore, any heat generated by the linear motor needs to be managed to avoid affecting the process or workpiece that the moving load is carrying. The motor constant  $K_m$  is a powerful parameter that can be used to determine this heat load,  $K_m$  equals:

$$K_m = \frac{F}{\sqrt{P_c}}$$

where the RMS force F is in Newtons, the RMS heat load  $P_c$  is in Watts and  $K_m$  is in units of  $\text{N}/\sqrt{\text{W}}$



The motor constant,  $K_m$ , allows us to determine motor performance capabilities such as shown in the following two examples. In the first example, we use  $K_m$  to calculate, for a given force, how many watts of generated heat are dissipated by the motor's coil assembly. In the second, we use  $K_m$  to determine the maximum RMS force developed by the motor when the dissipated power is limited to some value.

1. An application requires a continuous thrust force of 200 Newtons. The ICH11-050 ironcore motor is a good candidate, having a continuous force rating of 299 Newtons and a  $K_m$  of 38.0 N/ $\sqrt{W}$ . Therefore, since resistance rises 1.452 times at 145°C from the ambient value at 25°C, and since resistance is the square root denominator of  $K_m$ , we must write our equation as follows:

$$\text{Force} = \frac{K_m}{\sqrt{\text{Factor}}} \sqrt{\text{Power (dissipated)}}$$

$$200 = \frac{38.0}{\sqrt{1.452}} \sqrt{\text{Watts}}$$

$$\text{Power (dissipated)} = 40.2 \text{ Watts}$$

This value of watts is the power or heat generated by the motor.

2. The same application requires that no more than 20 watts are to be dissipated by the motor into the surrounding structure and environment. What is the maximum RMS force that the ICH11-050 motor may produce while not exceeding this power limit?

$$\text{Maximum RMS Force} = \frac{38.0}{\sqrt{1.452}} \sqrt{20} = 141 \text{ N}$$

Therefore, if the motor delivers no more than 141 N of thrust force on an RMS basis, then this same motor will not dissipate more than 20 watts.

### Continuous Force $F_c$ as a Function of Ambient Temperature

In our data sheets the continuous rated force  $F_c$  is the RMS force that the motor can supply continuously 100% of the time, assuming the ambient temperature is 25°C and with the coils achieving a maximum temperature of 130°C (IL series motors) respectively 145°C (ICH series motors). At higher or lower ambient temperatures, the  $F_c$  of the motor must be adjusted by a factor that is determined by the following equation:

$$\text{Factor} = \sqrt{\frac{(130 - \theta_{\text{Amb}})}{105}} \quad (\text{for IL series motors})$$

$$\text{Factor} = \sqrt{\frac{(145 - \theta_{\text{Amb}})}{120}} \quad (\text{for ICH series motors})$$

where  $\theta_{\text{Amb}}$  = Ambient Temperature in °C

#### This factor vs. ambient temperature works out as:

##### ICH Ironcore Linear Motors

5°C	10°C	15°C	20°C	25°C	30°C	35°C	40°C	45°C
1.080	1.061	1.041	1.021	1.000	0.979	0.957	0.935	0.913

##### IL Ironless Linear Motors

5°C	10°C	15°C	20°C	25°C	30°C	35°C	40°C	45°C
1.091	1.069	1.047	1.024	1.000	0.976	0.951	0.926	0.900

# Model Nomenclature

## Ironcore Types

**ICH 22 - 050 - A1 - TY - XX - 0**

### Coil Type

ICH = Ironcore High Voltage

### Coil Series

11 = 11 Series Ironcore  
 22 = 22 Series Ironcore  
 33 = 33 Series Ironcore  
 44 = 44 Series Ironcore

### Coil Width (mm)

030 = 30 mm      150 = 150 mm  
 050 = 50 mm      200 = 200 mm  
 075 = 75 mm      250 = 250 mm  
 100 = 100 mm

### Winding Code

A1: "Y"-Windings  
 A5: "Δ" Windings

### Reserved for Customizations

00. 01. 02 .....

### Cable Option Px ( $I_c < 15$ A) or Cx

Px = Cable with Connector for motors with  $I_c < 15$  A  
 Configuration (P1) includes 400 mm shielded cable with connector.

P1 = 400 mm  
 P2 = 200 mm  
 P3 = 100 mm  
 P4 = 1200 mm

Cx = Motor cable and thermal cable with flying leads:

C1 = 400 mm  
 C2 = 200 mm  
 C3 = 100 mm  
 C4 = 1200 mm

### Thermal Protection

TY = Standard (both PTC and KTY84-130)

## Magnetic Way Ironcore Types

**MCH 030 - 128 - 01**

### Magnet Way Type

MCH = Ironcore

### Magnet Way Width (mm)

030 = 30 mm      150 = 150 mm  
 050 = 50 mm      200 = 200 mm  
 075 = 75 mm      250 = 250 mm  
 100 = 100 mm

### Customization

01 = Standard with stainless steel cover  
 02. 03 .... Reserved

### Magnet Assembly Way Length (mm)

064 = 64 mm  
 128 = 128 mm  
 256 = 256 mm  
 512 = 512 mm

## Hall Effect Assembly Ironcore Types

**HD - Y - Px**

### Hall Option

HD = Digital

### Winding Phase Connection

Y = Y (Star) Windings  
 D = Δ (Triangle) Windings

### Cable Option

Px - Cable with Sub-D connector  
 P1 = 400 mm  
 P2 = 200 mm  
 P3 = 100 mm  
 P4 = 1200 mm

## Ironless Type

**IL 06 - 030 - A1 - TR - XX**

### Coil Type

IL = Ironless

### Coil Series

06 = 06 Series Ironless  
 12 = 12 Series Ironless  
 18 = 18 Series Ironless  
 24 = 24 Series Ironless

### Magnetic Way Width (mm)

030 = 30 mm  
 050 = 50 mm  
 075 = 75 mm  
 100 = 100 mm

### Winding Code

A1, A2, A3, A4: "Y"-Windings

### CableOption Px or Cx

Px = Cable with Connector:  
 Configuration (P1) includes 400 mm shielded cable with connector.  
 P1 = 400 mm  
 P2 = 200 mm  
 P3 = 100 mm  
 P4 = 1200 mm  
 Cx = Motor cable and thermal cable with flying leads:  
 C1 = 400 mm  
 C2 = 200 mm  
 C3 = 100 mm  
 C4 = 1200 mm

### Thermal Protection Option

TR = Thermistor  
 If No Thermal Protection. leave blank.

## Magnetic Way Ironless Types

**MW 030 - L - 0128**

### Magnet Way Type

MW = Ironless

### Magnet Way Width (mm)

030 = 30 mm  
 050 = 50 mm  
 075 = 75 mm  
 100 = 100 mm

### Magnet Assembly Way Length (mm)

0064 = 64mm  
 0128 = 128mm  
 0256 = 256mm  
 0512 = 512mm

L = Low Profile

(30 & 50 mm Ironless only)  
 For standard assemblies leave blank.

## Hall Effect Assembly Ironless Types

**HDIL 100 XX**

### Hall Effect

HDIL = Digital for Ironless (Microswitch SS461A)

### Winding Code

100 (A1, A2, A3, A4)  
 200 (A5, A6, A7, A8)

### Cable Option

Px - Cable with Connector:  
 Configuration (P1) includes 400 mm shielded cable with connector (lengths as above)  
 Cx - flying leads (lengths as above)

## About Kollmorgen

Kollmorgen is a leading provider of motion systems and components for machine builders. Through world-class knowledge in motion, industry-leading quality and deep expertise in linking and integrating standard and custom products, Kollmorgen delivers breakthrough solutions that are unmatched in performance, reliability and ease-of-use, giving machine builders an irrefutable marketplace advantage.

For assistance with your application needs visit [www.kollmorgen.com](http://www.kollmorgen.com) for a global contact list.

- Application Centers
- Global Design & Manufacturing
- Global Manufacturing

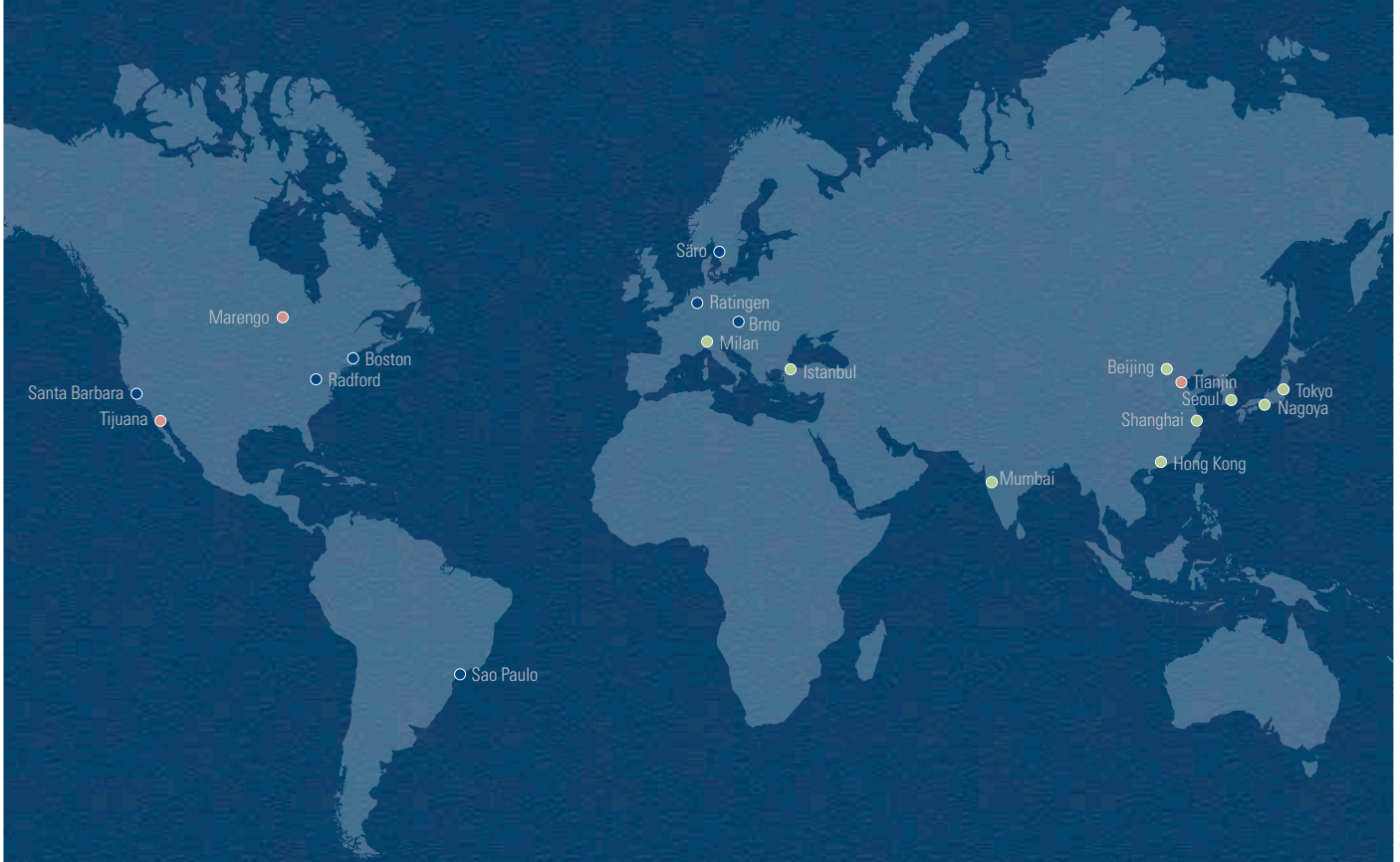

**KOLLMORGEN**®

*Because Motion Matters™*

Kollmorgen  
203A West Rock Road  
Radford, VA 24141 USA  
Phone: 1-540-633-3545  
Fax: 1-540-639-4162

Kollmorgen Europe GmbH  
Pempelfurtstraße 1  
40880 Ratingen  
Germany  
Phone: +49 (0) 2102 9394 0  
Fax: +49 (0) 2102 9394 3155

Kollmorgen Asia  
Rm 202, Building 3, Lane 168  
Lin Hong Road  
Changning District, Shanghai 200335, China  
Phone: +86 400 661 2802  
[sales.china@kollmorgen.com](mailto:sales.china@kollmorgen.com)